

THIS DOCUMENT IS THE PROPERTY OF
KEYSTONE ELECTRONICS CORP. AND
SHALL NOT BE REPRODUCED, DISTRIBUTED
OR USED AS A BASIS FOR MANUFACTURE
WITHOUT PRIOR WRITTEN PERMISSION
FROM KEYSTONE ELECTRONICS CORP.

ACTUAL SIZE

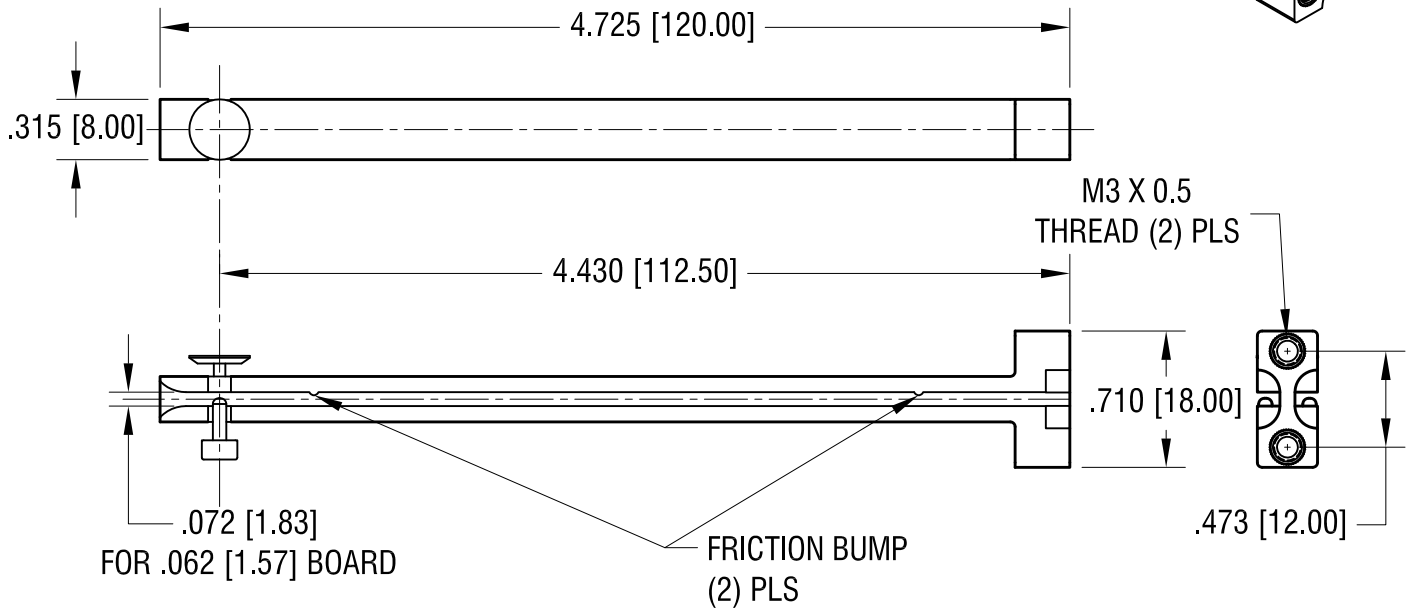
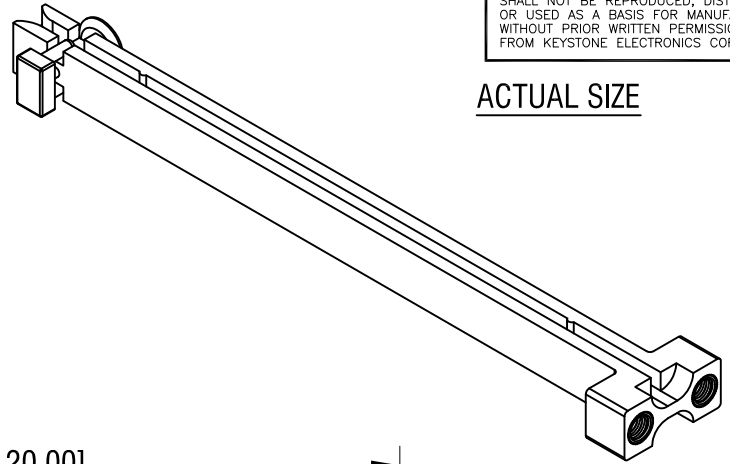

NOTE:

1. GUIDE: MAT'L- NYLON GLASS FILLED
(COLOR-BLUE)
2. INSERT: MAT'L- BRASS
FINISH- NICKEL PLATE

3. HARDWARE: MAT'L- STEEL
FINISH- ZINC PLATE
(2) PLS LOCKWASHER
(2) PLS FLAT WASHER
(2) PLS SCREW M3 x 8mm L,

KEYSTONE ELECTRONICS CORP.

www.keyelco.com • NEW HYDE PARK, NY 11040 • Tel (516) 328-7500

PART NAME		VERTICAL CARD GUIDE	
MATERIAL		AS NOTED	
FINISH		DRN BY	DATE
AS NOTED		NT	2.14.15
		APP'D	SCALE
		RH	1X
TOLERANCES	INCH [MM]	CODE	DWG NO.
DECIMAL	± .010 [± 0.25]	C	8648
ANGULAR	± 1°		
UNLESS OTHERWISE SPECIFIED			

5.21.21	IDENTIFY FRICTION BUMPS CHANGE AS PER ECN 21-045	B
8.05.15	ECN 15-075, ADD NOTE 3.	A
DATE	DESCRIPTION	REV.