

HI0805O121R-10

PHYSICAL DIMENSIONS:

A	2.00 [.079]	+ 0.20 [.008]
B	1.25 [.049]	+ 0.20 [.008]
C	0.90 [.035]	+ 0.20 [.008]
D	0.51 [.020]	+ 0.25 [.010]

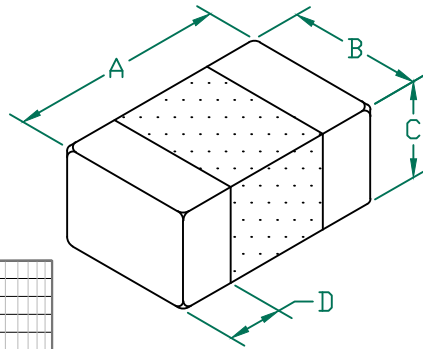

ELECTRICAL CHARACTERISTICS:		
Z @ 100MHz (Ω)	DCR (Ω)	Rated Current
Nominal	120	
Minimum	90	
Maximum	150	3500 mA

NOTES: UNLESS OTHERWISE SPECIFIED

1. TAPED AND REELED per CURRENT EIA SPECIFICATIONS 7" REELS, 4000 PCS/REEL, PAPER TAPER.
2. COMPONENTS SHOULD BE ADEQUATELY PREHEATED BEFORE SOLDERING.
3. TERMINATION FINISH IS 100% TIN.
4. OPERATING TEMPERATURE TEMP: -40°C~+125°C (INCLUDING SELF-HEATING)

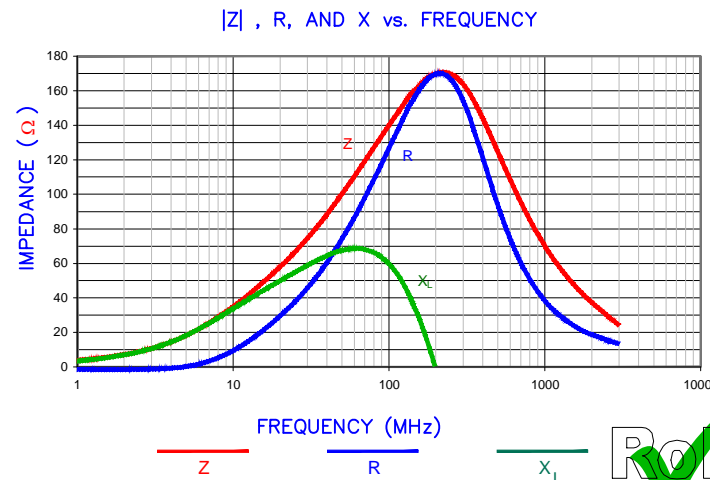
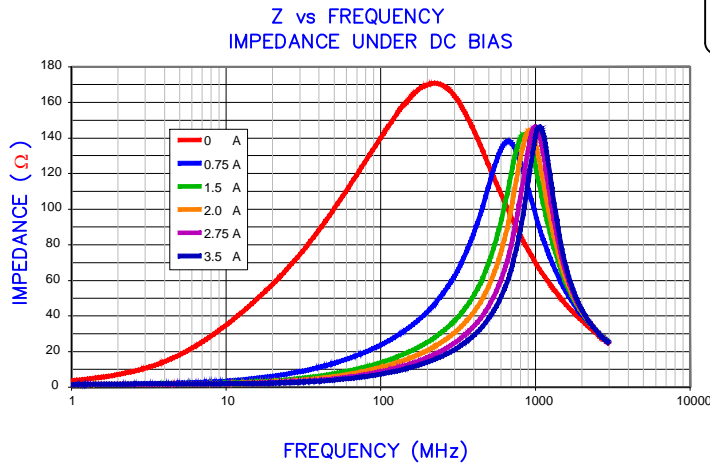

LAND PATTERNS FOR REFLOW SOLDERING

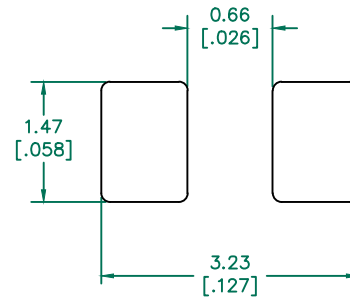

(For wave soldering, add 0.763 [.030] to this dimension.)

RECOMMENDED SOLDERING CONDITIONS

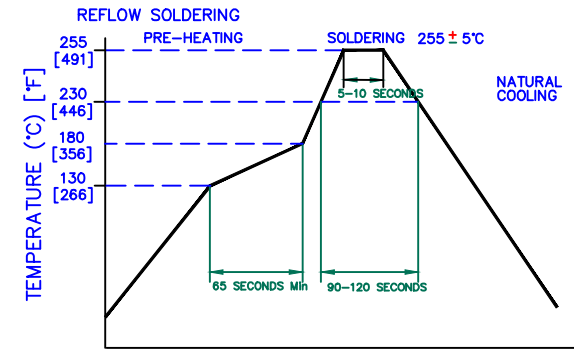

AGILENT E4991A RF Impedance/Material Analyzer
HP 16194A Test Fixture REF. 5522



DIMENSIONS ARE IN mm [INCHES].				This print is the property of Laird Tech. and is loaned in confidence subject to return upon request and with the understanding that no copies shall be made without the written consent of Laird Tech. All rights to design or invention are reserved.		Laird	
F	OPERATING TEMPERATURE UPDATE LAIRD LOGO AND REFLOW CURVE	08/05/13	QU	REV	F	PART TYPE: CO-FIRE	DRAWN BY: JRK
E	CHANGE TO PAPER TAPE	03/04/10	JUN	PROJECT/PART NUMBER:	HI08050121R-10		
D	UPDATE COMPANY LOGO & ROHS SYMBOL	06/01/09	JRK	DATE:	08/23/04	SCALE:	NTS
C	UPDATE COMPANY LOGO	01/16/08	JRK	CAD #	HI08050121R-10-F	TOOL #	
B	UPDATE CURVES	03/29/06	JRK	SHEET: 1 of 1			
A	ORIGINAL DRAFT	08/23/04	JRK				
REV	DESCRIPTION	DATE	INT				