

**Ratings**

Voltage: 600 V  
 Temperature: -40~105 °C  
 Flammability: FT2

**Conductor**

Conductor count: 2  
 Gauge: 16 AWG 1.31 mm<sup>2</sup>  
 Material: tinned copper strands  
 Strand size:  $\phi 0.16 \times 65$   
 Resistance at 20 °C: 15  $\Omega$  /km max

**Insulator**

Material: mPPE  
 Color: red, black  
 Diameter:  $\phi 2.4 \pm 0.10$  mm  
 Average thickness: 0.43 mm  
 Minimum thickness: 0.34 mm  
 Resistance at 20 °C: 100 M $\Omega$  /km min

**Shield**

Type: foil  
 Material: aluminum mylar  
 Coverage: 100%

**Outer jacket**

Material: mPPE, 85A  
 Color: black  
 Diameter:  $\phi 7.5 \pm 0.30$   
 Average thickness: 1.3 mm  
 Minimum thickness: 0.91 mm

**Wire marking:** E339579 UL AWM STYLE 21509 16 AWG 105°C  
 600V --- cUL AWM I A 105°C 600V FT2 TENSILITY

**Bend radius**

Minimum: 6 times diameter (45 mm)

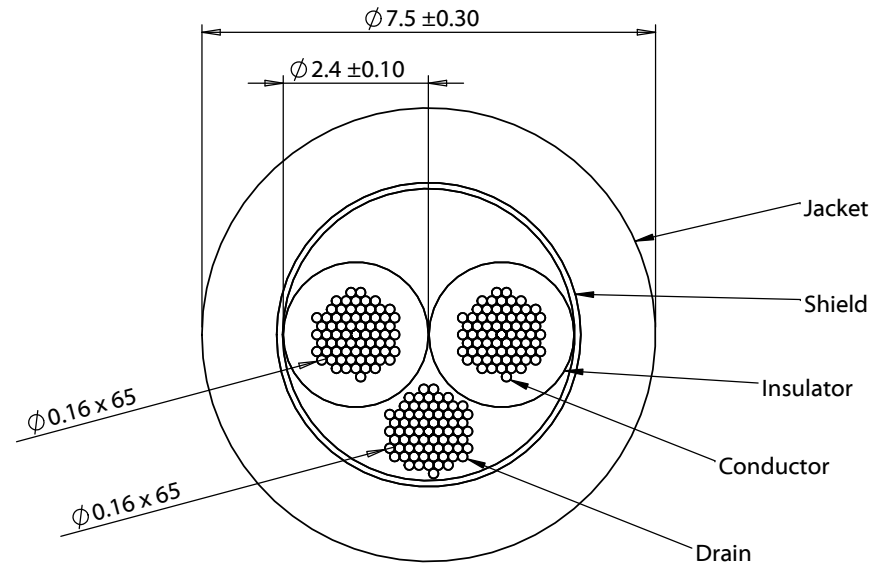
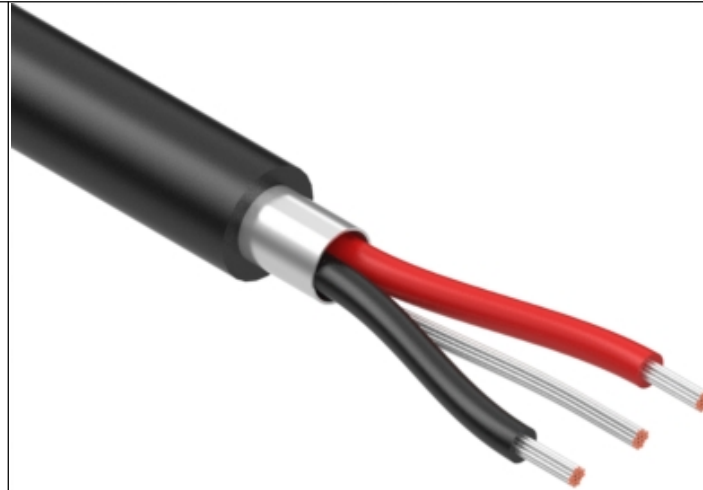

Revision:	Date:	Description:	Prepared:	Notes:	<b>TENSILITY</b> tel 1.541.323.3228 800 877.670.7118 fax 1.541.323.4202 web tensility.com
A	4/20/2020	Initial release	Verified:	RoHS compliant Phthalate and halogen free	
			Dimensions are in millimeters. Tolerances: X: ± 0.5 mm X.X: ± 0.3 mm X.XX: ± 0.05 mm	Description:	Size: Part number:
				Wire, 2C TS, 16 AWG, 21509, 600V, 105C, 7.5 mm, shielded, FT2, mPPE	A 30-01400
				Scale: 8:1	Sheet 1 of 1

5

4

3

2

1