

断面図 (参考)

注記 NOTES

1. 使用材料 MATERIAL
 ハウジング : 液晶ポリマー ガラス充填, UL94V-0(白)
 HOUSING : LIQUID CRYSTAL POLYMER GLASS FILLED, UL94V-0 (WHITE)
 アクチュエータ : ポリアミド 9T, ガラス充填, UL94V-0(茶)
 ACTUATOR : POLYAMIDE 9T, GLASS FILLED, UL94V-0 (BROWN)
 ターミナル : 銅合金(t=0.15)
 TERMINAL : COPPER ALLOY
 金具 : 銅合金(t=0.2)
 FITTING NAIL : COPPER ALLOY
 2. めっき仕様 PLATING
 ターミナル TERMINAL
 コンタクト部 : 部分金めっき(0.1μm以上)
 テール部 : 部分金めっき
 下地 : ニッケルめっき(1.0μm以上)
 CONTACT AREA : SEPARATED GOLD PLATING (0.1 MICROMETER MINIMUM)
 SOLDER TAIL AREA : SEPARATED GOLD PLATING UNDERPLATE : NICKEL OVERALL
 金具 FITTING NAIL
 ニッケル下地めっき
 銅めっき(1.0μm以上)
 ニッケルめっき(1.0μm以上)
 TIN(Sn) OVER NICKEL(Ni) PLATING.
 TIN PLATING (1.0 MICROMETER MINIMUM)
 NICKEL PLATING (1.0 MICROMETER MINIMUM)
 3. テールと金具を併せた平坦度は 0.1ミリメートル以下(リフロー前)
 TAILS AND NAILS COPLANARITY TO BE 0.1 MAX. (BEFORE REFLOW)
 4. ELV及びRoHS適合品
 ELV AND RoHS COMPLIANT
- △ R0.3は、FPC導体部にかからないこと。
 R0.3 MUST NOT BE OVERLAPPED TO PATTERN OF FPC.

8	35.7	37.1	37.4	34.5	37.8	501951-7019	70
	30.7	32.1	32.4	29.5	32.8	501951-6019	60
	25.7	27.1	27.4	24.5	27.8	501951-5019	50
	23.2	24.6	24.9	22	25.3	501951-4519	45
	20.7	22.1	22.4	19.5	22.8	501951-4019	40
	16.7	18.1	18.4	15.5	18.8	501951-3219	32
	15.7	17.1	17.4	14.5	17.8	501951-3019	30
	12.7	14.1	14.4	11.5	14.8	501951-2419	24
	11.7	13.1	13.4	10.5	13.8	501951-2219	22
10.7	12.1	12.4	9.5	12.8	501951-2019	20	
F	E	D	C	B	A	MATERIAL NO.	CIRCUITS

REVISED EC NO: J2015-1526 DRAWN: ISHII 2015/05/18 CHK: KAKAHASHI 2015/05/18 APPR: YNOGAWA 2015/05/20	GENERAL TOLERANCES (UNLESS SPECIFIED)			DIMENSION STYLE MM ONLY		SCALE 10:1	DESIGN UNITS METRIC	THIRD ANGLE PROJECTION
	0.25 UNDER			±0.03	DRAWN BY TRSUZUKI	DATE 2006/08/21	TITLE 0.5 FPC CONN. HSG ASSY EASY ON / STRAIGHT (GOLD)	
	0.25 OVER	0.5 UNDER			±0.05	CHECKED BY HIRATA	DATE 2006/08/21	molex
	0.5 OVER	1.0 UNDER			±0.1	APPROVED BY MSASAO	DATE 2006/08/21	
	1.0 OVER	10 UNDER			±0.2	MATERIAL NO.	DOCUMENT NO.	
10 OVER	30 UNDER			±0.25	SEE CHART		SD-501951-003	
30 OVER					±0.3	SHEET NO. 1 OF 2		
ANGULAR ±1 °					DRAFT WHERE APPLICABLE MUST REMAIN WITHIN DIMENSIONS		THIS DRAWING CONTAINS INFORMATION THAT IS PROPRIETARY TO MOLEX INCORPORATED AND SHOULD NOT BE USED WITHOUT WRITTEN PERMISSION	

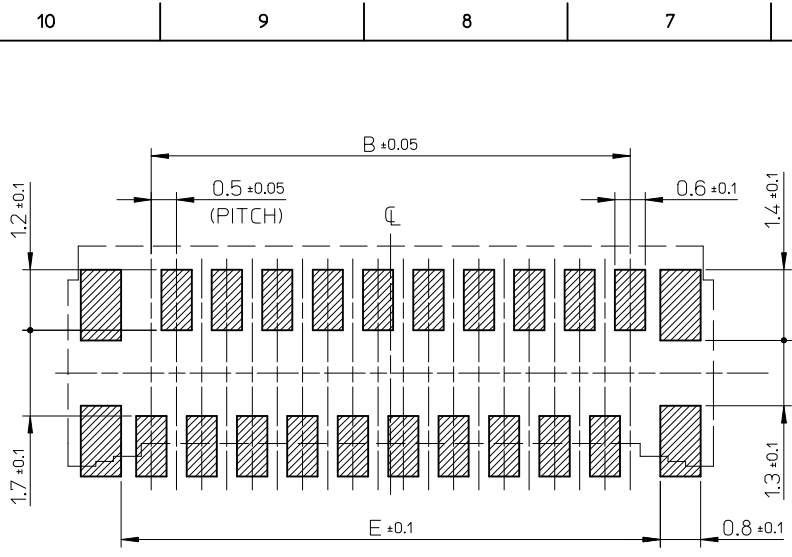

参考基板レイアウト (マウント面)
P.C. BOARD PATTERN DIMENSION (REF.)
(MOUNT AREA)

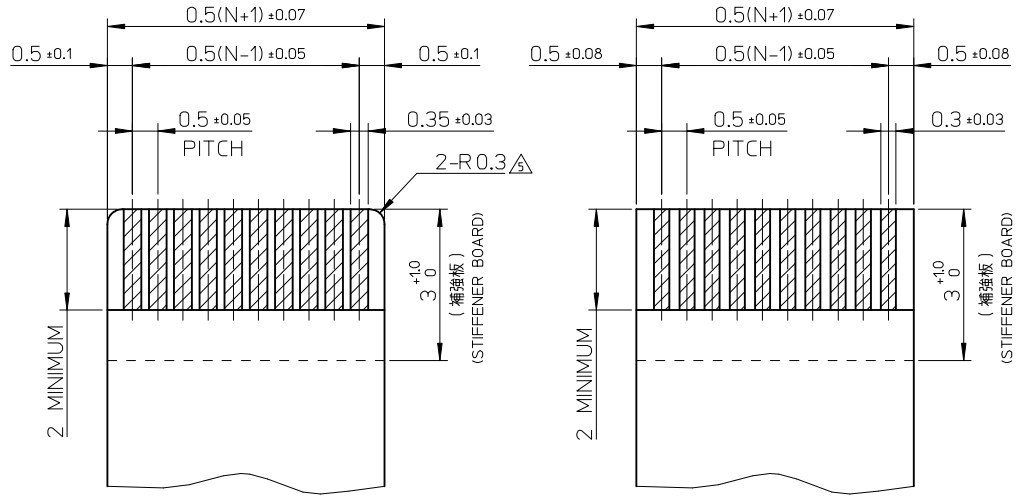

適合FPC推奨寸法
APPLICABLE FPC
RECOMMENDED DIMENSION
(仕上がり厚さ: 0.3 ± 0.05)
(THICKNESS: 0.3 ± 0.05)

N: 極数
N: CIRCUITS

適合FFC推奨寸法
APPLICABLE FFC
RECOMMENDED DIMENSION
(仕上がり厚さ: 0.3 ± 0.05)
(THICKNESS: 0.3 ± 0.05)

N: 極数
N: CIRCUITS

FPCについて ABOUT FPC

補強フィルム材質はポリイミドを推奨します。ベースフィルムは25μmを推奨します。
接着剤は熱硬化接着剤を推奨します。
尚、接着剤の接点部への付着は導通不良の原因になりますので、染み出しが無い様お願い致します。
RECOMMENDED MATERIAL/THICKNESS.
RECOMMENDED STIFFENER MATERIAL: POLYIMIDE
RECOMMENDED BASE FILM THICKNESS: 25 MICROMETER
RECOMMENDED ADHESIVE: THERMOSETTING ADHESIVE
NOTE: PLEASE PUT APPROPRIATE AMOUNT OF ADHESIVE ON ADHEREND BECAUSE THERE IS A POSSIBILITY THAT THE EXTRA ADHESIVE CAUSES THE DEFECT IN ELECTRICAL CONTINUITY.
THERE IS A POSSIBILITY THAT THE PRESCRIPT TEMPERATURE OF FFC IS SET TO SINGLE IT.

FPC/FFCについて ABOUT FPC/FFC

打ち抜き方向は導体側から補強板側を推奨します。
導体部については軟箔銅35μmまたは50μmを推奨します。
FFCに規定された定格温度がFFC単体前提である場合が御座います。
コネクタと組み合わせての実使用において、接着層が劣化するなどの信頼性を満足できないケースを回避するため、実機での評価/確認をお願い致します。
RECOMMENDED PUNCHING DIRECTION: FROM CONDUCTOR SIDE TO STIFFENER SIDE
RECOMMENDED CONDUCTOR SPEC: SOFT COPPER FOIL
RECOMMENDED CONDUCTOR THICKNESS: 35 MICROMETER OR 50 MICROMETER
NOTE: WHEN ACTUALLY USING IT WITH CONNECTOR, PLEASE DO THE EVALUATION AND THE CONFIRMATION WITH AN ACTUAL EQUIPMENT TO EVADE THE CASE WHERE RELIABILITY CANNOT BE FILLED (THE ADHESIVE LINE OF FFC IS DETERIORATED ETC.)

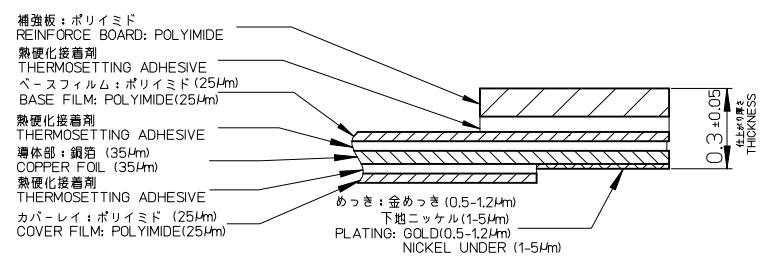

FPC構成推奨仕様
STRUCTURE OF FPC

SEE SHEET 1 OF 2 EC NO: J2015-1526 DRAWN BY: DRWNAISHI 2015/05/18 CHECKED BY: CHKD:TAKAHASHI 2015/05/18 APPR: YNOGAWA 2015/05/20	GENERAL TOLERANCES (UNLESS SPECIFIED)		DIMENSION STYLE MM ONLY		SCALE ---	DESIGN UNITS METRIC	THIRD ANGLE PROJECTION
	0.25 UNDER	±0.03	DRAWN BY	DATE	TITLE		
	0.25 OVER 0.5 UNDER	±0.05	TRSUZUKI	2006/08/21	0.5 FPC CONN. HSG ASSY EASY ON / STRAIGHT (GOLD)		
	0.5 OVER 1.0 UNDER	±0.1	CHECKED BY	DATE	molex		
1.0 OVER 10 UNDER	±0.2	HIRATA	2006/08/21	APPROVED BY	DATE	MATERIAL NO.	DOCUMENT NO.
10 OVER 30 UNDER	±0.25	MSASAO	2006/08/21	SEE SHEET 1 OF 2		SD-501951-003	SHEET NO. 2 OF 2
30 OVER	±0.3	DRAFT WHERE APPLICABLE MUST REMAIN WITHIN DIMENSIONS		SIZE A3	THIS DRAWING CONTAINS INFORMATION THAT IS PROPRIETARY TO MOLEX INCORPORATED AND SHOULD NOT BE USED WITHOUT WRITTEN PERMISSION		

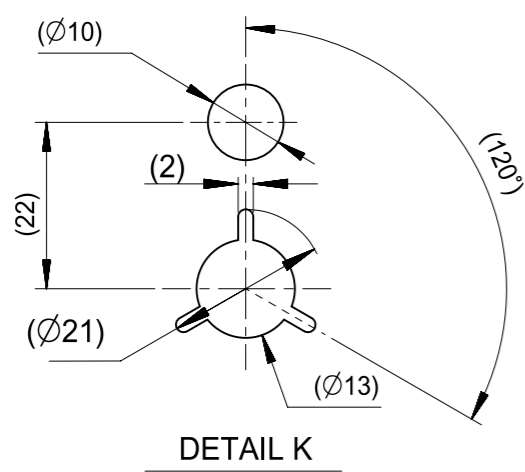
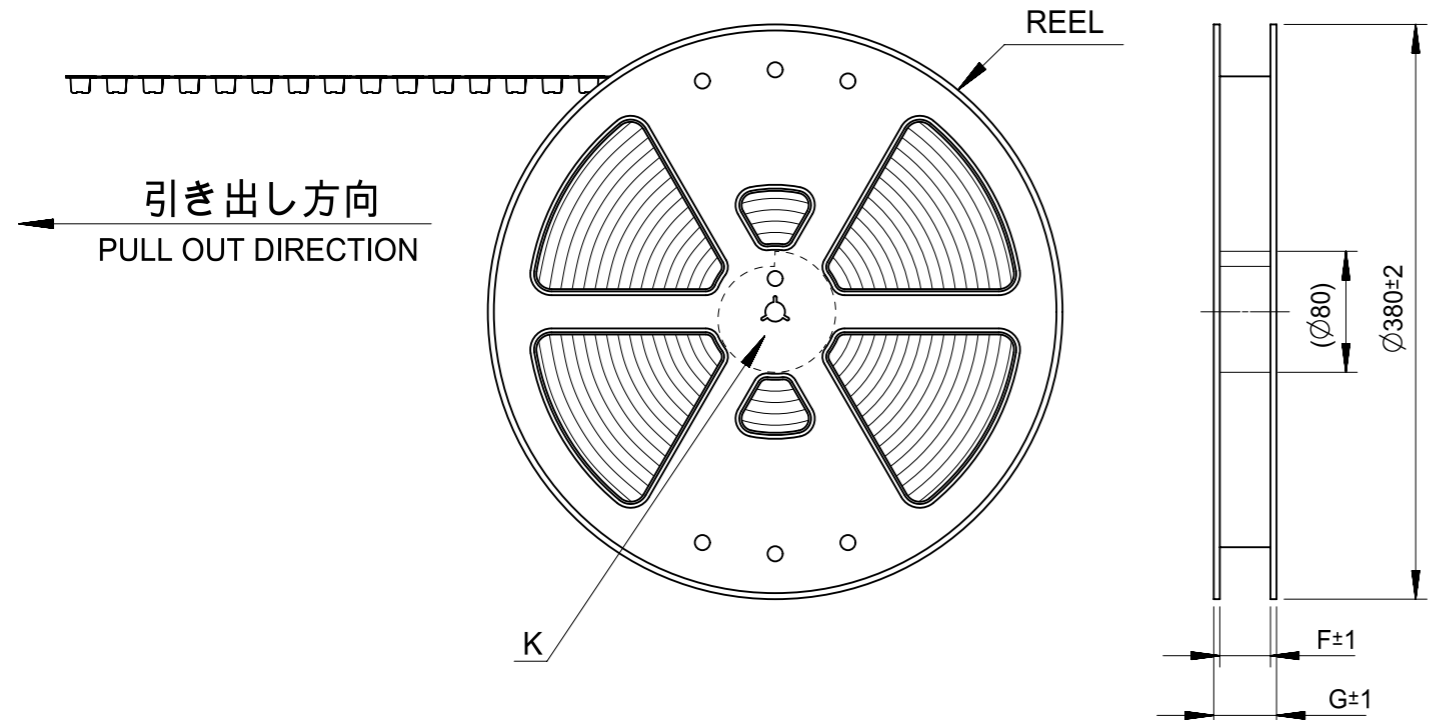

NOTES

- 製品詳細寸法については図面 SD-501951-003を参照下さい。
FOR DIMENSIONS OF PRODUCT, REFER TO SD-501951-003.
- 梱包数量：2000個/リール
NUMBER OF CONNECTORS：2000PIECES/REEL
- リードテープ長さ
LEAD TAPE LENGTH

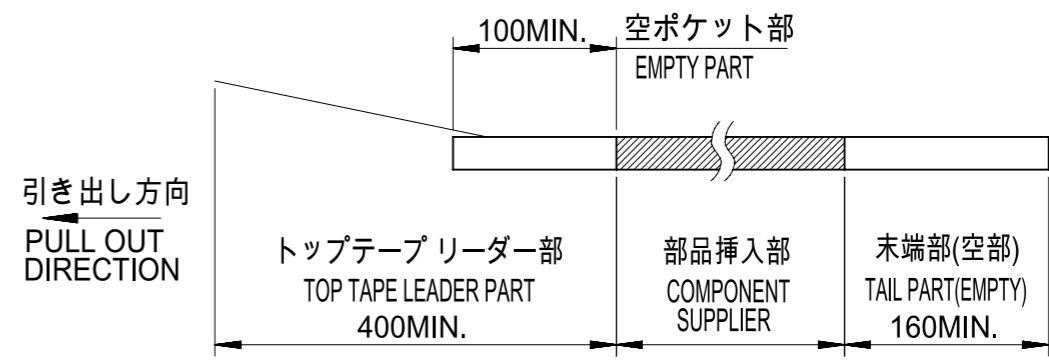

- トッパーテープの剥離強度については、IEC60286-3に準拠
TOP TAPE PEEL FORCE IS DEFINED BY IEC 60286-3.
- 材料 MATERIAL
キャリアテープ：ポリスチレン
CARRIER TAPE：POLYSTYRENE
トッパーテープ：ポリエチレンテレフタレート、ポリエチレン
TOP TAPE：POLYETHYLENE TEREPHTHALATE, POLYETHYLENE
リール：ポリスチレン<リサイクル材を含む>
REEL：POLYSTYRENE<RECYCLE MATERIAL CONTAINED>
- ELV及びRoHS適合品 ELV AND RoHS COMPLIANT

THIS DRAWING CONTAINS INFORMATION THAT IS PROPRIETARY TO MOLEX ELECTRONIC TECHNOLOGIES, LLC AND SHOULD NOT BE USED WITHOUT WRITTEN PERMISSION									
DIMENSION UNITS		SCALE		CURRENT REV DESC:				molex	
mm		10:1							
GENERAL TOLERANCES (UNLESS SPECIFIED)									
ANGULAR TOL		± 1.0 °		EC NO: 601584				0.5 FPC CONN. HSG ASSY	
4 PLACES		± 0.05		DRWN: SKAWAKAMI 2018/09/21				E/O STRAIGHT EMBSTP PKG (GOLD)	
3 PLACES		± 0.1		CHK'D: TRSUZUKI 2018/09/25				PRODUCT CUSTOMER DRAWING	
2 PLACES		± 0.2		APPR: RTAKEUCHI 2018/12/25				DOCUMENT NUMBER	
1 PLACE		± 0.25		INITIAL REVISION:				DOC TYPE	
0 PLACES		± 0.3		DRWN: TRSUZUKI 2006/08/31				DOC PART	
DRAFT WHERE APPLICABLE MUST REMAIN WITHIN DIMENSIONS				THIRD ANGLE PROJECTION		DRAWING		REVISION	
				A3-SIZE		SERIES		SD-501951-004	
				501951		MATERIAL NUMBER		PSD 001 F	
						CUSTOMER		GENERAL MARKET	
								SHEET NUMBER	
								1 OF 2	

引き出し方向
PULL OUT DIRECTION

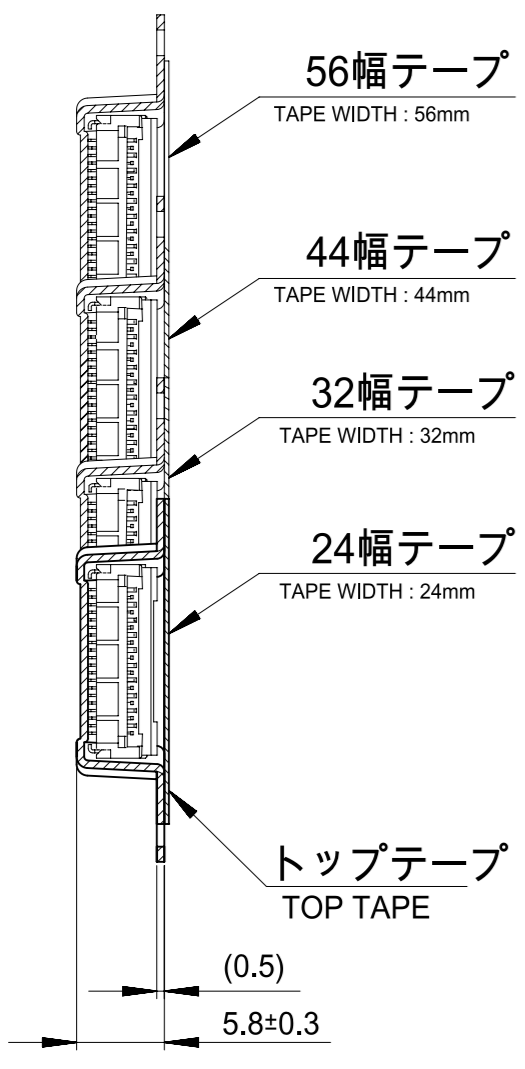

断面 Y-Y
SECTION Y-Y

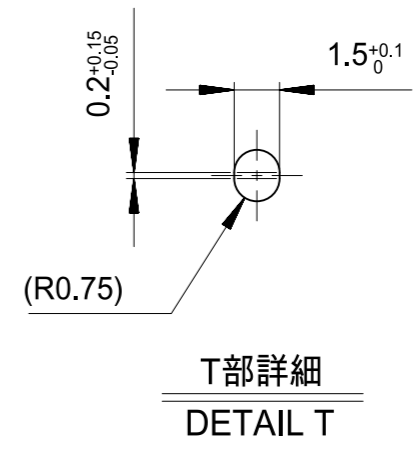
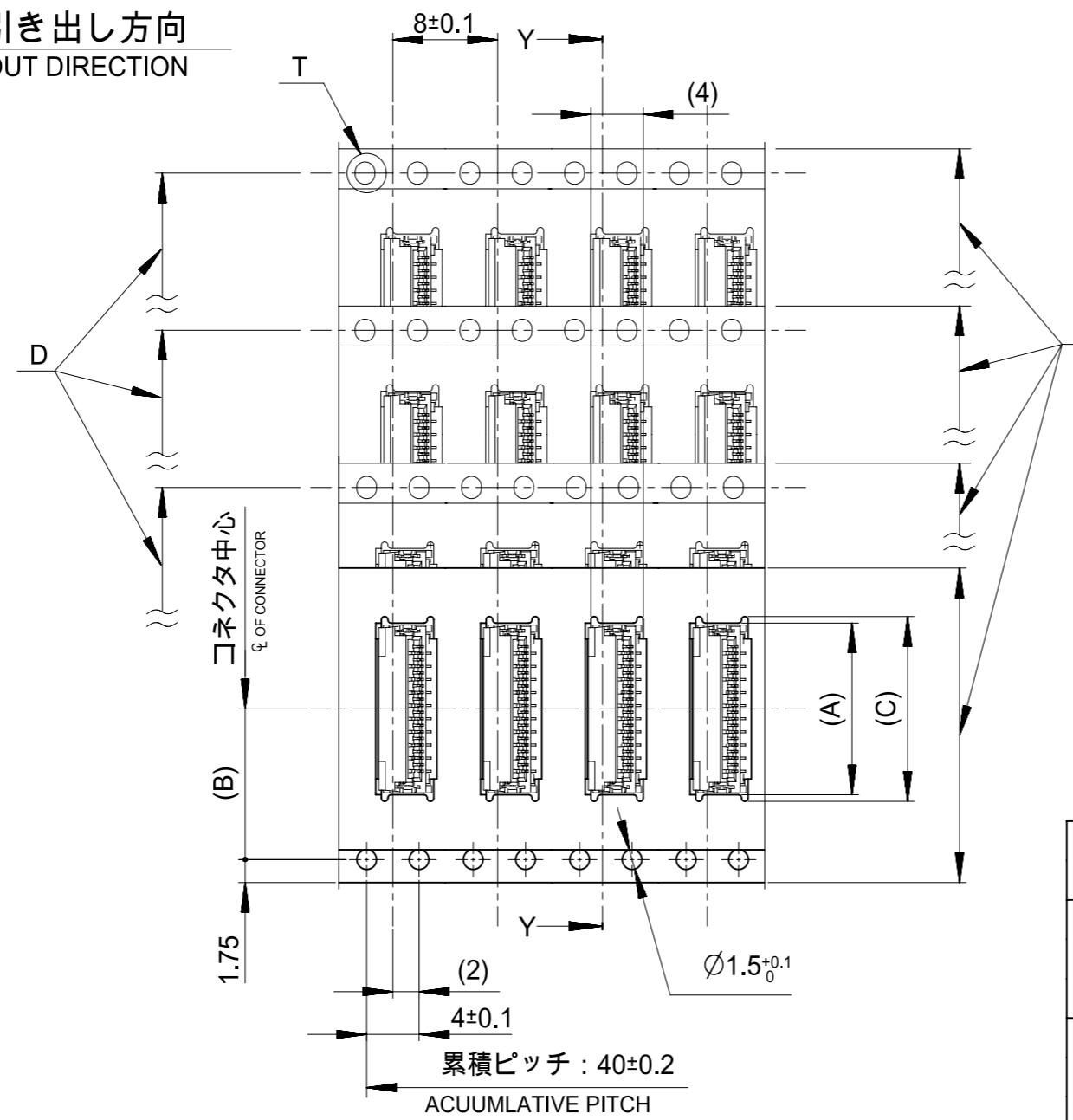

61.4	57.4	56±0.3	52.4	39.1	26.2	38.1	501951-7010	70
				34.1		33.1	501951-6010	60
49.4	45.4	44±0.3	40.4	29.1	20.2	28.1	501951-5010	50
				26.1		25.6	501951-4510	45
				24.1		23.1	501951-4010	40
37.4	33.4	32±0.3	28.4	20.1	14.2	19.1	501951-3210	32
				19.1		18.1	501951-3010	30
				16.1		15.1	501951-2410	24
29.4	25.4	24±0.3	-	15.1	11.5	14.1	501951-2210	22
				14.1		13.1	501951-2010	20
G	F	E CARRIER TAPE WIDTH		D	(C)	(B)	(A)	MATERIAL NO. CIRCUITS

THIS DRAWING CONTAINS INFORMATION THAT IS PROPRIETARY TO MOLEX ELECTRONIC TECHNOLOGIES, LLC AND SHOULD NOT BE USED WITHOUT WRITTEN PERMISSION

DIMENSION UNITS mm	SCALE 10:1	CURRENT REV DESC:		molex			
GENERAL TOLERANCES (UNLESS SPECIFIED)		EC NO: 601584					
ANGULAR TOL	± 1.0 °	DRWN: SKAWAKAMI 2018/09/21		PRODUCT CUSTOMER DRAWING			
4 PLACES	± 0.05	CHK'D: TRSUZUKI 2018/09/25		DOCUMENT NUMBER			
3 PLACES	± 0.1	APPR: RTAKEUCHI 2018/12/25		SD-501951-004			
2 PLACES	± 0.2	INITIAL REVISION:		DOC TYPE			
1 PLACE	± 0.25	DRWN: TRSUZUKI 2006/08/31		PSD			
0 PLACES	± 0.3	APPR: HHIRATA 2006/09/05		DOC PART			
DRAFT WHERE APPLICABLE MUST REMAIN WITHIN DIMENSIONS		THIRD ANGLE PROJECTION		REVISION			
		DRAWING		001			
		SERIES		F			
		MATERIAL NUMBER		SHEET NUMBER			
		A3-SIZE 501951		2 OF 2			
		CUSTOMER		GENERAL MARKET			