

© - TE Connectivity. All Rights Reserved.

REVISIONS					
P	LTR	DESCRIPTION	DATE	DWN	APVD
	T	REVISED PER ECR-22-152397	07OCT2022	BB	DSC

<b>AMP</b> WIRE RANGE	Listed FILE E13288	LR7189 Certified
16-14 AWG SOLID OR STRANDED	16-14 AWG SOLID OR STRANDED	16-14 AWG SOLID OR STRANDED

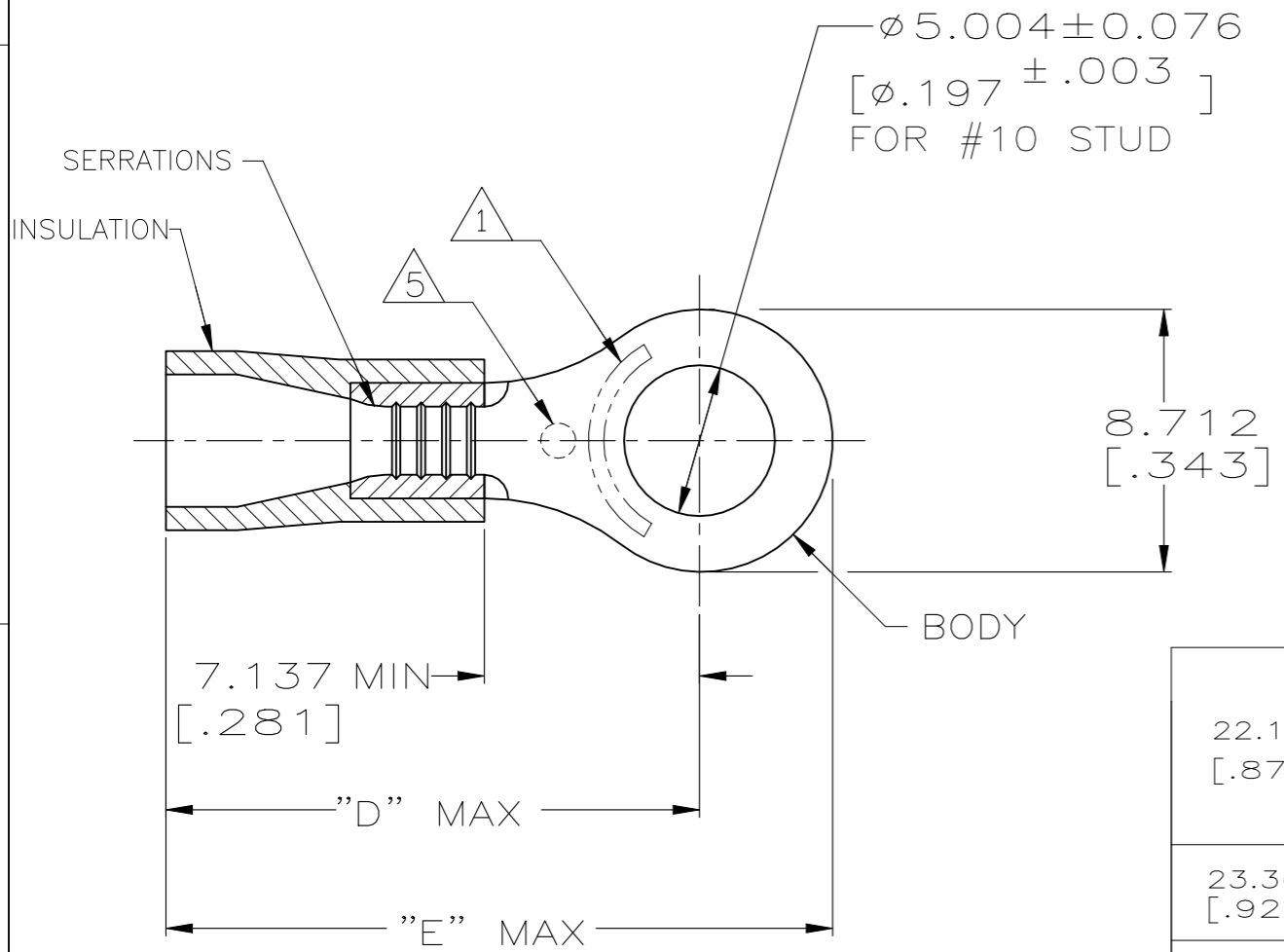

- 1 STAMP AMP 16-14\* APPROX AS SHOWN
- 2 BODY MATERIAL THK:  $0.787 \pm 0.051$  [.031 ± .002]
- 3 MATERIAL:  
BODY - COPPER PER ASTM B152  
INSULATION - PVC
- 4 FINISH:  
BODY - TIN PLATE  $0.00254$  [.000100]  
MIN EXT THK PER ASTM B545  
INSULATION COLOR - BLUE
- 5 "O" STAMP MARK OPTIONAL

22.123 [.871]	17.704 [.697]	2.997-4.902 [.118-.193]	100	LOOSE PC, BOX	8-34161-1
23.368 [.920]	18.948 [.746]	3.810-6.350 [.150-.250]	5000	ON TAPE, REEL	2-34161-3
			1000	LOOSE PIECE	2-34161-2
22.123 [.871]	17.704 [.697]	2.997-4.902 [.118-.193]	5000	ON TAPE, REEL	2-34161-1
			1000	LOOSE PIECE	34161
"E"	"D"	WIRE INSULATION DIA	QTY	PACKAGE TYPE	PART NUMBER

**AMP INCORPORATED**  
**CUSTOMER SERVICE SYSTEMS**

FOR ADDITIONAL PRODUCT INFORMATION OR COPIES OF DRAWINGS AND TECHNICAL DOCUMENTS  
PRODUCT INFORMATION CENTER  
1-800-522-6752

FOR APPLICATION TOOLING INFORMATION  
TOOLING ASSISTANCE CENTER  
1-800-722-1111

FOR ORDER ENTRY  
1-800-526-5142

MAX RECOMMENDED OPERATING TEMPERATURE:  
105°C [221° F]

VOLTAGE RATING:  
N/A

CIRCULAR MIL AREA:  
1.04-2.62mm<sup>2</sup> [2,050-5,180]  
SOLID OR STRANDED

THIS DRAWING IS A CONTROLLED DOCUMENT.

DIMENSIONS:  
mm [INCHES]

TOLERANCES UNLESS OTHERWISE SPECIFIED:

0 PLC ± -  
1 PLC ± -  
2 PLC ± -  
3 PLC ± 0.127[.005]  
4 PLC ± -  
ANGLES ± -

MATERIAL

FINISH

DWN DK SCHRUM 08/06/92  
CHK RE HERSEY 11/10/92  
APVD M ELLIS 11/10/92  
PRODUCT SPEC  
UL 486A-B  
APPLICATION SPEC  
114-2161  
WEIGHT -

**STE** TE Connectivity

NAME  
TERMINAL, RING TONGUE,  
PLASTI-GRIP,  
WIRE SIZE: 16-14 AWG

SIZE CAGE CODE DRAWING NO RESTRICTED TO  
A3 00779 C-34161 -

CUSTOMER DRAWING SCALE 4:1 SHEET 1 OF 1 REV T