

THIS COPY IS PROVIDED ON A RESTRICTED BASIS AND IS NOT TO BE USED IN ANY WAY DETRIMENTAL TO THE INTERESTS OF PANDUIT CORP.

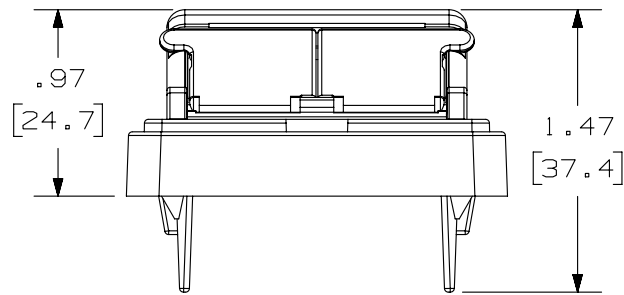
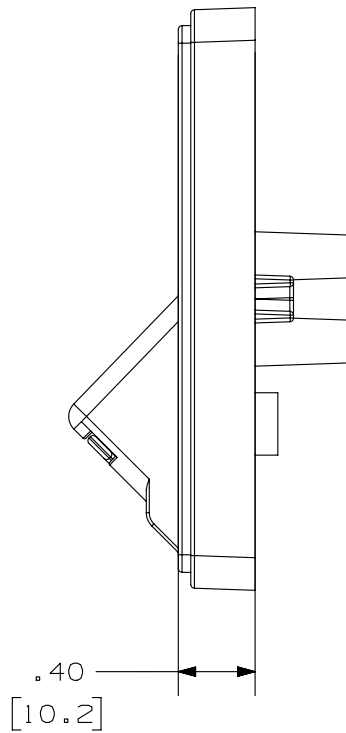
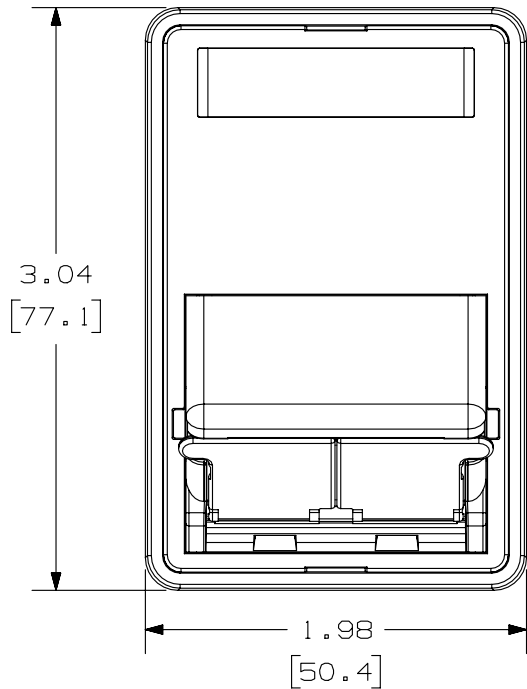

PANDUIT P/N	WEIGHT
CFPDS2S**Y	.66 LB/10 PCS (299.4 g/10 PCS)

NOTES:

- SEE CURRENT CATALOG FOR ADDITIONAL PART NUMBER SUFFIXES TO INDICATE COLOR AND OR PACKAGE QUANTITY.
- SEE CATALOG FOR COMPLETE LIST OF PARTS APPLICABLE FOR USE WITH THIS PART.
- DIMENSIONS IN [ ] ARE IN METRIC.
- PART INCLUDES:
  - 1- SLOPED SHUTTERED INSERT (CHS2S\*\*)
  - 1- ADAPTER
  - 1- BEZEL
  - 2- MOUNTING SCREW
  - 2- HOLDING CLAMP
  - 1- LABEL
  - 1- LABEL COVER

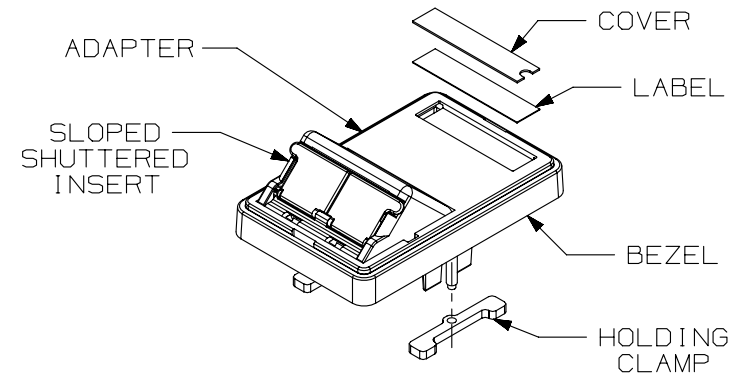

PART NUMBER		CFPDS2S**Y	
TITLE			
MINI-COM 2 POSITION DENMARK SLOPED SHUTTERED INSERT FACEPLATE			
CUSTOMER DRAWING			
ITEM REVISION NAME		M02479FX/00	
DATASET FILE NAME		M02479FX_DC156/00B	
UNLESS OTHERWISE SPECIFIED, DIMENSIONAL TOLERANCES ARE: IN [mm]		MATERIAL:	
.x ± .xxx ± .010 [ .3 ]		INSERT- ABS	
.xx ± .03 [ .8 ]		ADAPTER- ABS	
ANGLES ±		BEZEL- ABS	
THIRD ANGLE PROJECTION		HOLDING CLAMP -CRS	
DRAWING NUMBER:		02479-156	
DRAWN BY	DATE	CHK	SCALE
JSP	3-18-06	MJD	NONE
SHT 1 OF 1			SIZE
			A

REV	DATE	BY	CHK	APR	DESCRIPTION	ECN
1	4/2/14	JSP	REFR	MMR	A. REVISED DRAWING TITLE BLOCK.	02479-156
R	3-18-06	JSP	MJD	MJD	RELEASED TO PRODUCTION	02479-156

D10100DA/14

2

1

2

1