



# KIT-CRD-3DD12P Buck Boost Evaluation Kit

Wolfspeed Power Marketing

# Overview of KIT-CRD-3DD12P Evaluation Board

- Evaluate and optimize steady state and high speed switching performance of Wolfspeed C3M™ SiC MOSFETs and Schottky diodes
- Analyze the evaluation board in versatile power conversion topologies, such as Synchronous / Asynchronous Buck or Boost converter, Half Bridge and Full Bridge (Please note: Full Bridge require 2 Evaluation Kits)
- Board features footprints for both 3 and 4 lead TO-247 packages of C3M™ SiC MOSFETs
- Compatible with both TO-247 and TO-220 packages of SiC Schottky diodes
- Does not require an additional capacitor to run the evaluation board in the buck or boost converter topologies
- Two (2) dedicated gate drivers available on the board for each C3M™ SiC MOSFET
- Includes (2) 1200 V, 75mΩ (C3M™) SiC MOSFETs in a TO-247-4 Package with the testing hardware



*(KIT-CRD-3DD12P Evaluation Board)*

# Physical layout of KIT-CRD-3DD12P Evaluation Board

- Physical dimensions of a fully assembled KIT-CRD-3DD12P evaluation board are 222 mm X 97 mm X 49 mm

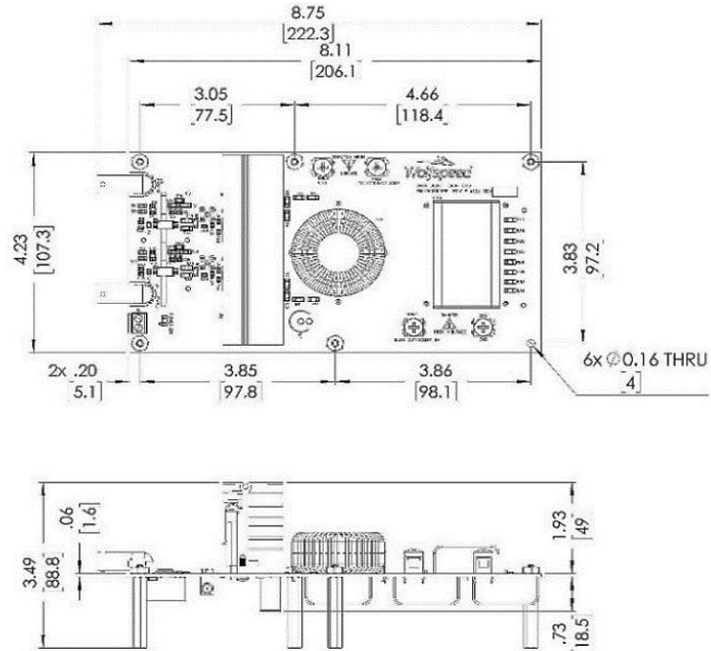

*(Physical layout of the evaluation board)*

# Electrical Specifications of KIT-CRD-3DD12P

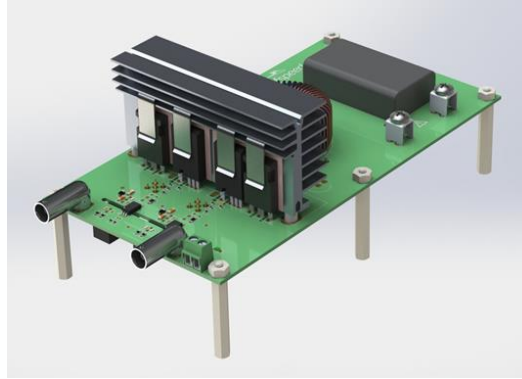

Max Input Voltage	800V
Max Output Voltage	800V
Max Output Power	2.5kW**
V <sub>CC</sub> (Logic Power)	15VDC
Frequency	100kHz**

*(\*\* Power and frequency limits are based on the inductor. Different output power and switching frequency can be achieved with a different inductor.)*

# Example Topologies

- KIT-CRD-3DD12P evaluation board as a synchronous buck converter:

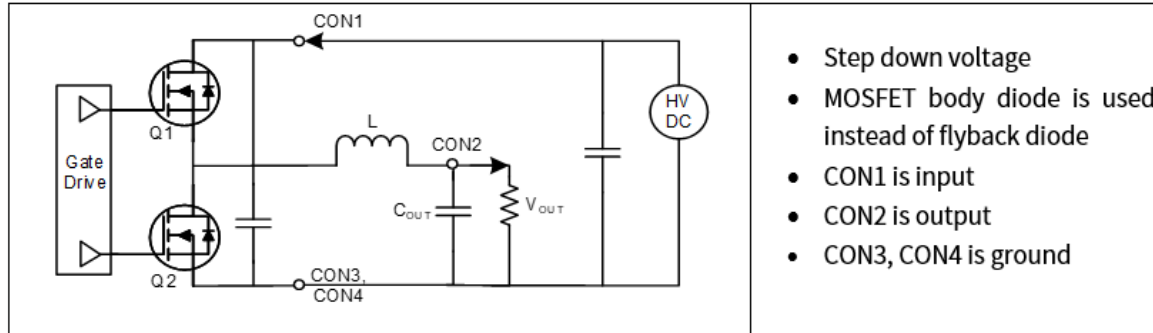

- KIT-CRD-3DD12P evaluation board as a synchronous boost converter:

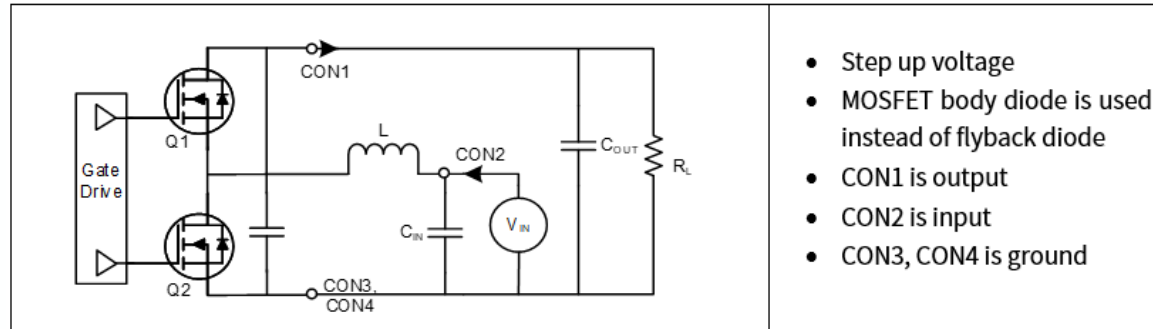

## Example Topologies (Continued)

- KIT-CRD-3DD12P evaluation board as a asynchronous buck converter:

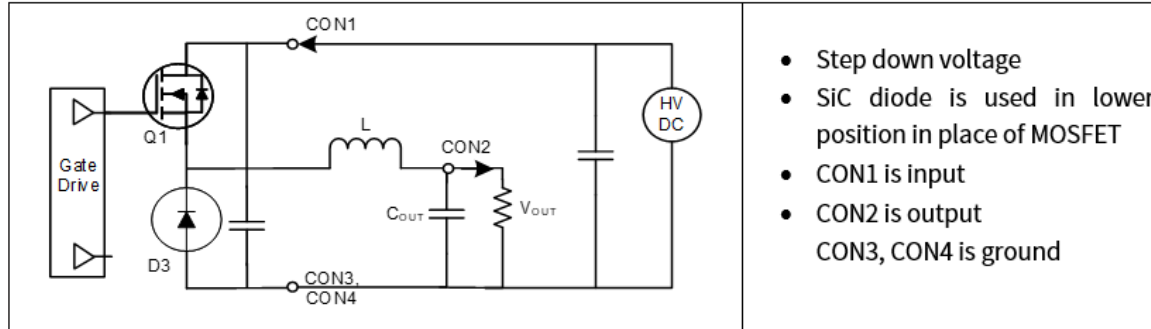

- KIT-CRD-3DD12P evaluation board as a asynchronous boost converter:

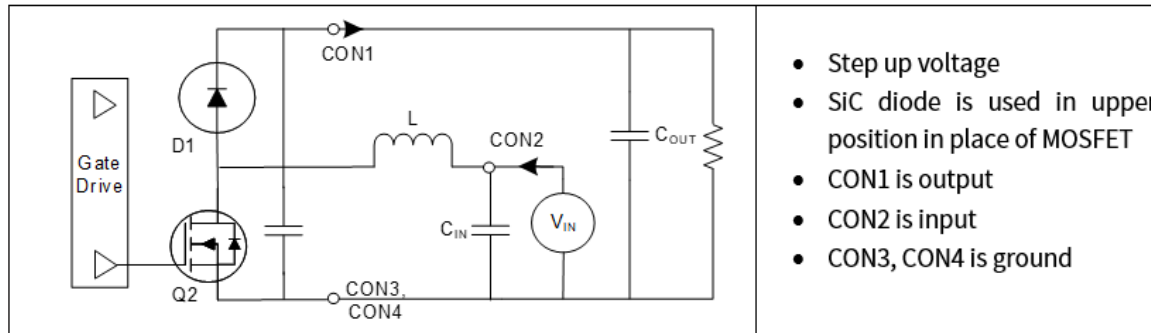

# Physical Location of Terminals and connectors

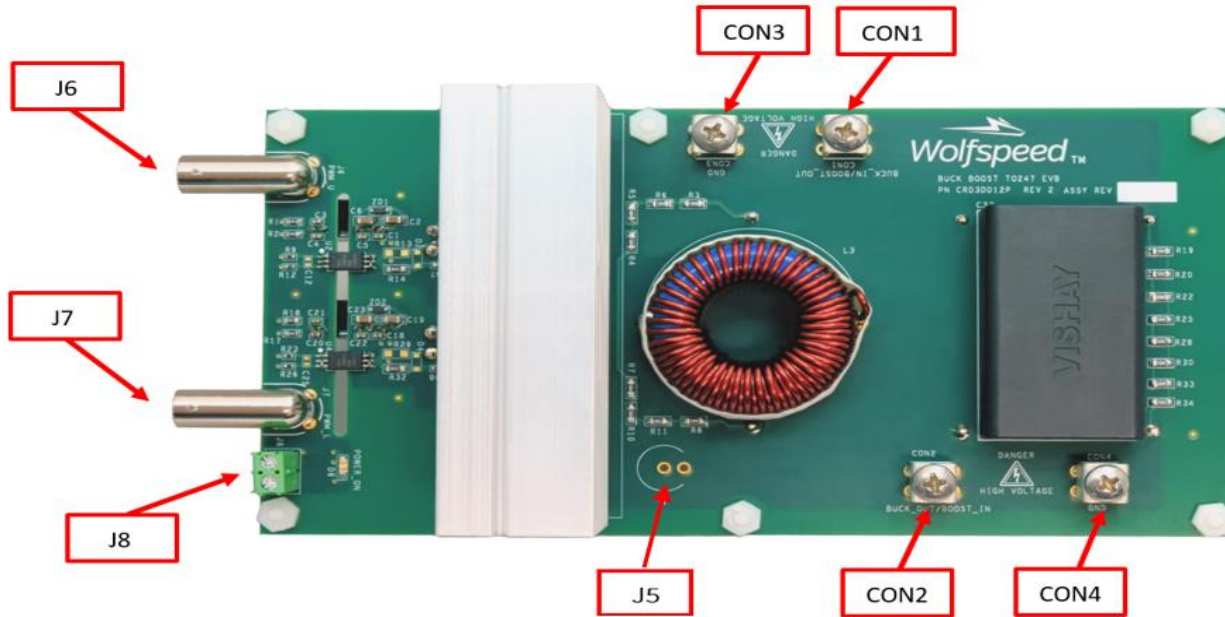

(Top side view of the evaluation board with the physical location of terminals and connectors)

# Description of Terminals and connectors

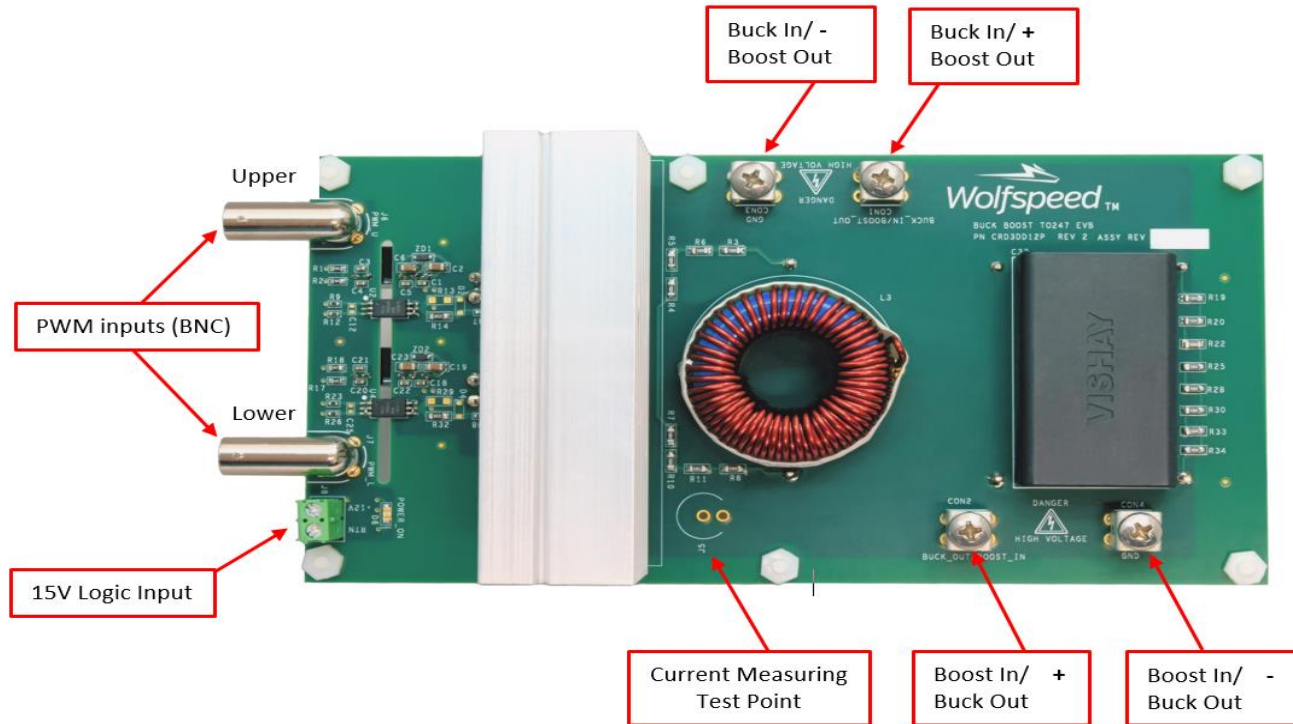

*(Top side view of the evaluation board with the description of terminals and connectors)*



# Test Point Locations (For TO-247-4L MOSFETs)

- Cree's KIT-CRD-3DD12P evaluation board comes in a TO-247-4L configuration by default
- An SMA connector also included in the evaluation kit for capturing clean switching waveforms

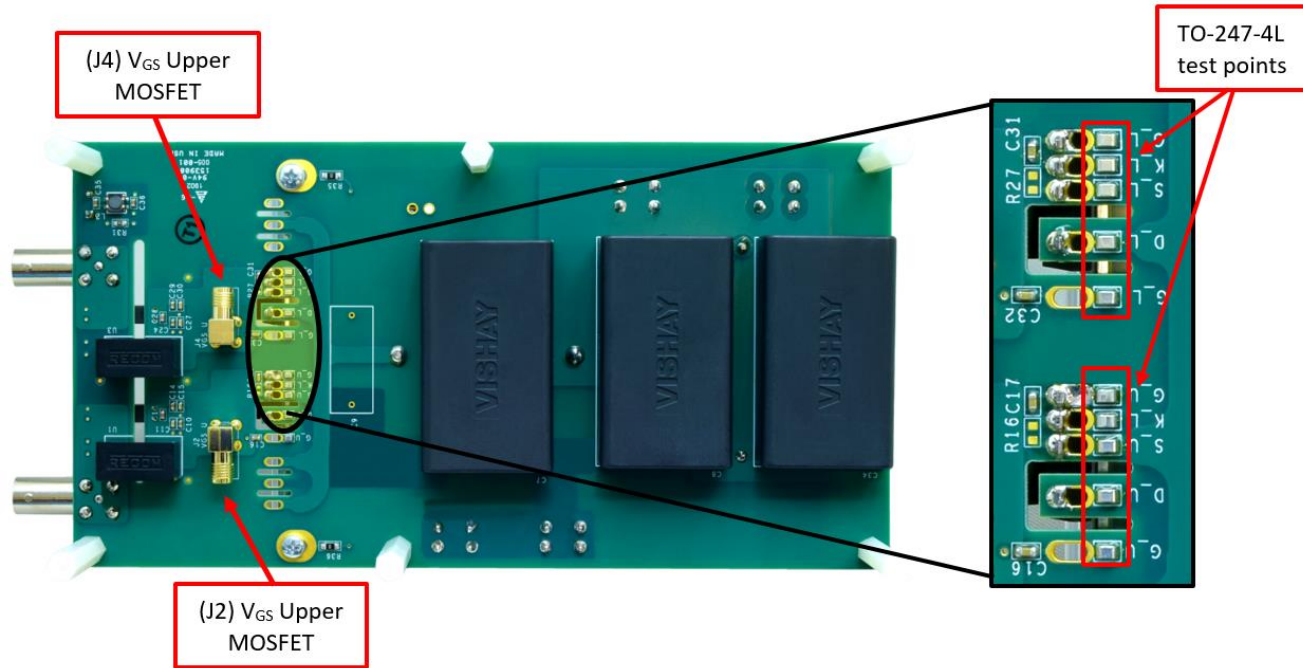

*(Bottom side view of the evaluation board with the identification of Test Point Locations)*

# Configuring Evaluation Board for TO-247-3L MOSFETs

- To convert either the upper or the lower MOSFET position into a TO-247-3L configuration, a 0Ω 0603 type resistor must be populated in each resistor position (R16, R27) located on the bottom side of the PCB

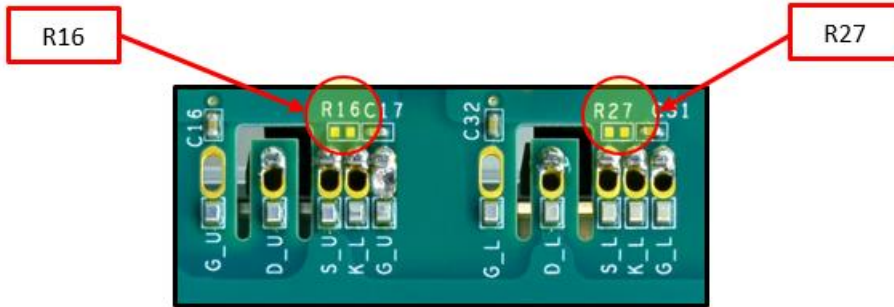

*(Location of resistors (R16 & R27) on the bottom side of the evaluation board)*

Device	Resistor
Upper MOSFET (Q1)	R16
Lower MOSFET (Q2)	R27

*(Description of resistors (R16 & R27))*

# Current Sensing

- Cree's KIT-CRD-3DD12P, Buck-Boost Evaluation Kit comes with a placeholder (J5) (Current Measuring Test Point)
- Users can sense current waveforms by placing a current viewing device at J5

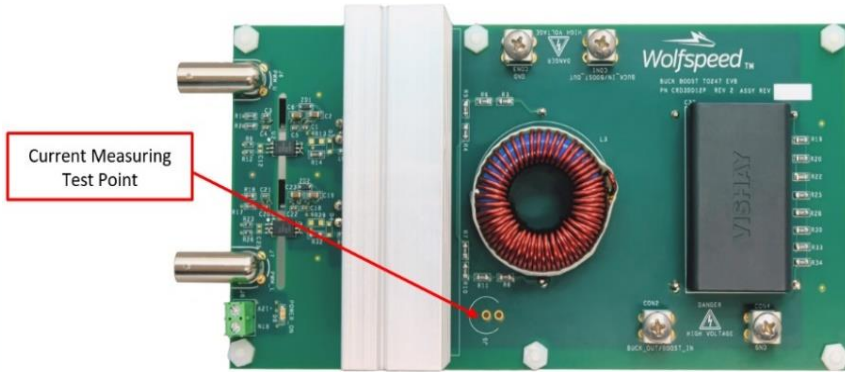

*(Top View of the evaluation board with current measuring test point)*

*(View of current sensing device installed on the evaluation board)*

*(Please note that Cree's KIT-CRD-3DD12P, Buck-Boost Evaluation Kit will not work without a current sensing device or without populating a jumper at J5)*

# Example Application 1 (Boost Converter)

- Cree's KIT-CRD-3DD12P, Buck-Boost Evaluation Kit can be analyzed as a Asynchronous Boost Converter
- In this case, a SiC diode is placed at the upper position while a SiC MOSFET is placed at the lower position
- By placing oscilloscope probes at the appropriate test point locations, clean switching waveforms of  $V_{GS}$ ,  $V_{DS}$  (Drain to Source Voltage) and  $I_D$  (Drain Current) can be viewed on oscilloscope

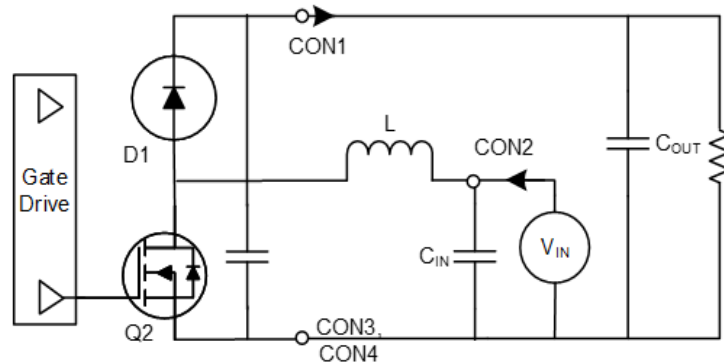

(Asynchronous Boost Converter)

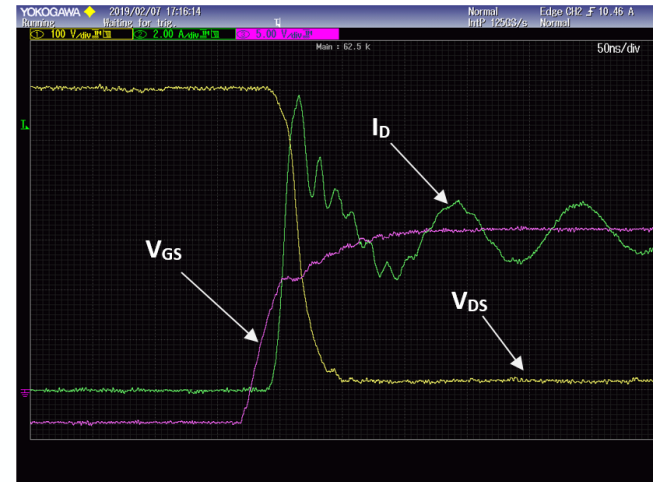

(Switching Waveforms)

## Example Application 2 (Buck Converter)

- Cree's KIT-CRD-3DD12P, Buck-Boost Evaluation Kit can be analyzed as a Synchronous and Asynchronous Buck Converter as well
- In the case of Synchronous Buck Converter, a SiC MOSFET is placed both at the upper and the lower positions
- While in Asynchronous Buck Converter, a SiC MOSFET is placed at the upper position and a SiC diodes is placed at the lower position

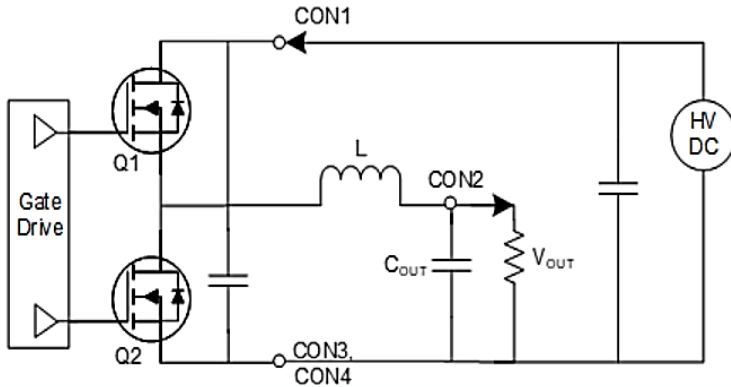

*(Synchronous Buck Converter)*

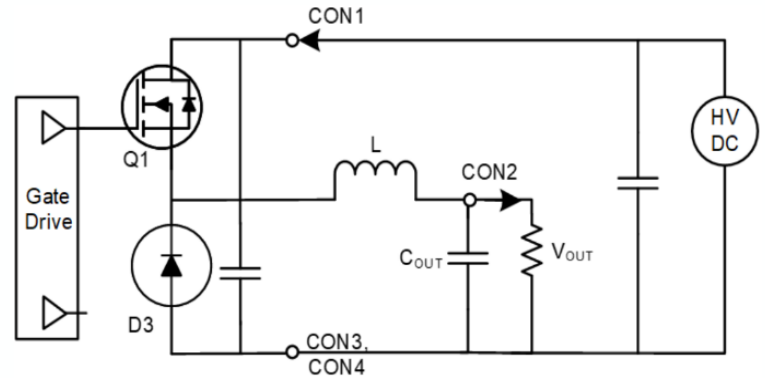

*(Asynchronous Buck Converter)*

## Example Application 2 (Buck Converter) (Continued)

- By analyzing Cree's KIT-CRD-3DD12P evaluation board at full power (2.5 kW) in both Asynchronous and Synchronous Buck converter topologies, favorable efficiency results can be achieved
- In Synchronous Buck Converter arrangement, at full power (2.5 kW), Cree SiC MOSFETs and the inductor remains well within the thermal limits

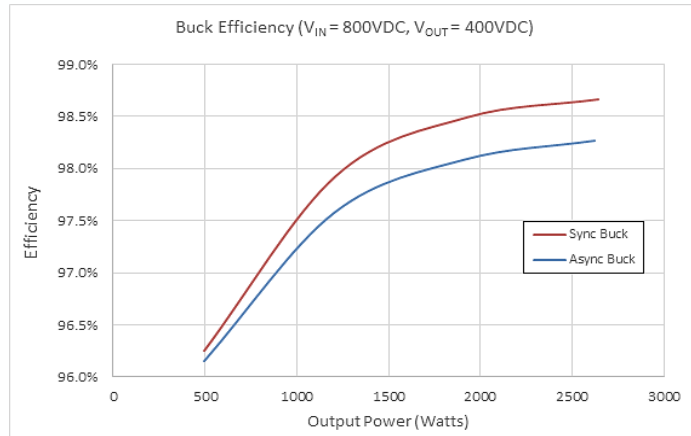

(Synchronous/ Asynchronous Buck Converter Efficiency Vs Output Power)

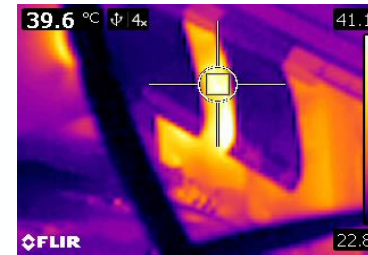

(Thermal Scan of MOSFETs)

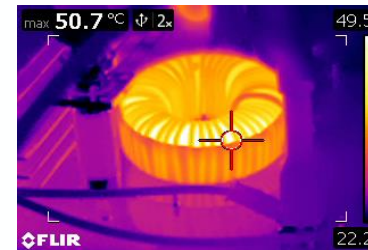

(Thermal Scan of Inductor)

# Summary

- Evaluate and optimize the steady state and dynamic switching performance of both SiC (C3M™) MOSFETs (TO-247-3, TO-247-4) and SiC Schottky diodes (TO-247, TO-220)
- Analyze the evaluation board in versatile power conversion topologies i.e. Synchronous / Asynchronous Buck or Boost converter, Half Bridge and Full Bridge (Require 2 kits)
- No additional capacitor required to run the evaluation board in the boost or buck converter topologies
- By using Cree's KIT-CRD-3DD12P evaluation board, users can conveniently measure ringing free switching waveforms ( $V_{GS}$ ,  $V_{DS}$  etc..) and the system level efficiency at full power (2.5 kW) while maintaining the temperature of MOSFETs and the Inductor well within the limits

*(If user require more information about the detailed operation of Cree's KIT-CRD-3DD12P evaluation board please review Cree's KIT-CRD-3DD12P evaluation board's Application Note)*

*(If user have questions about Cree's KIT-CRD-3DD12P evaluation board, please contact Cree at [sic\\_power@cree.com](mailto:sic_power@cree.com))*

# Appendix

- Schematic of Cree's KIT-CRD-3DD12P Evaluation Board
- Package Contents of Cree's KIT-CRD-3DD12P Evaluation Board

*(If user require more information about the detailed operation of Cree's KIT-CRD-3DD12P evaluation board please review Cree's KIT-CRD-3DD12P evaluation board's Application Note)*

*(If user have questions about Cree's KIT-CRD-3DD12P evaluation board, please contact Cree at [sic\\_power@cree.com](mailto:sic_power@cree.com))*



# Schematic of KIT-CRD-3DD12P Evaluation Board

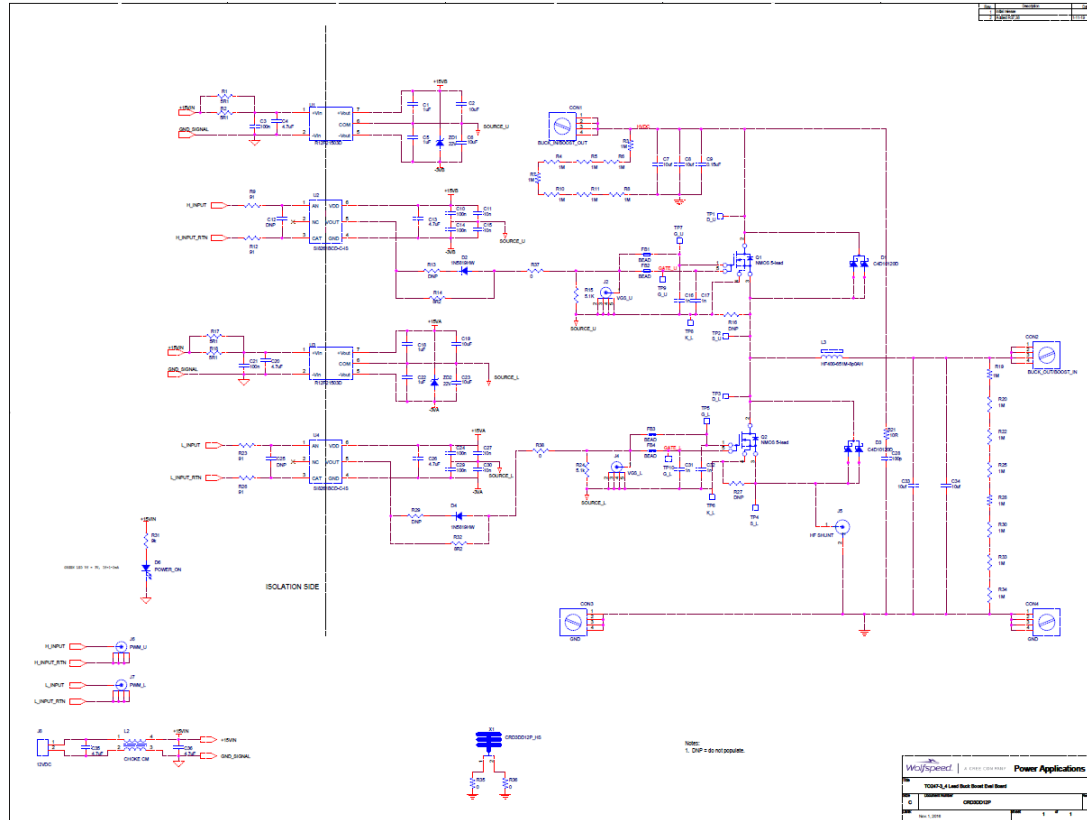

**Note:** a larger copy of the schematic may be obtained upon request by contacting Cree at [sic\\_power@cree.com](mailto:sic_power@cree.com)

# Package contents of KIT-CRD-3DD12P Evaluation Board

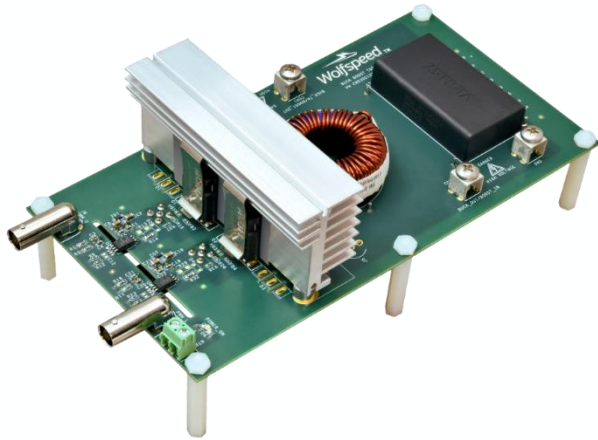

222 mm X 97 mm X 49 mm

ITEM NO.	QTY.	DESCRIPTION	Mfg.	P/N
1	1	CRD-3DD12P rev22 Buck Boost Eval Board Assy.	Make	CRD-3DD12P
2	4	High force clip	Aavid Thermalloy	MAX03-HNG
3	1	Heat sink extrusion, custom length 4 in.	Aavid Thermalloy	780603U04000G
4	2	MOSFET, 1200V, 75 mohm	Cree	C3M0075120K
5	4	Kapton Thermal Interface (Cut to 22mm x 29mm rectangle)	Fischer Elektronik	KAP 1 P
6	1	Foam insert top	Make	See drawing
7	1	Conductive foam strip	Make	See drawing
8	1	S/N Label	Make	n/a
9	1	Cover graphic Label	Make	n/a
10	1	Foam insert	Make	See drawing
11	6	Male-Female Threaded Hex Standoff Nylon 6/6, 1/4" Hex Size, 1-1/2" Long, 6-32 to 6-32	McMaster-Carr	92745A348
12	2	Spacer, 1/4" OD, 5/32" Length, un-threaded Al, #6 screw	McMaster-Carr	92510A031
13	6	Nylon Hex Nut, 6-32 Thread Size	McMaster-Carr	94812A300
14	2	Phillips Round Head Screw, M3 x 0.5 mm Thread, 10 mm Long	McMaster-Carr	92005A120
15	2	Steel Split Lock Washer for M3 Screw Size, 3.4 mm ID, 6.2 mm OD	McMaster-Carr	91202A222
16	1	Package Box	Uline	S-16677
17	3	2"x3" 4mil re-closeable poly bag	Uline	S-12269
18	1	ESD Label on box	Uline	S-2245
19	2	CONN ADAPT SMA PLUG TO BNC JACK	Amphenol	242102

