

| MAT'L NO. | ENG NO. | STUD SIZE | "S" SLOT ±.010 (0.25) |
|-----------|-----------|-----------|--------------------------|
| 191640069 | SC-241-06 | #6 | .146 (3.71) |
| 191640070 | SC-241-08 | #8 | .173 (4.39) |
| 191640071 | SC-241-10 | #10 | .198 (5.03) |

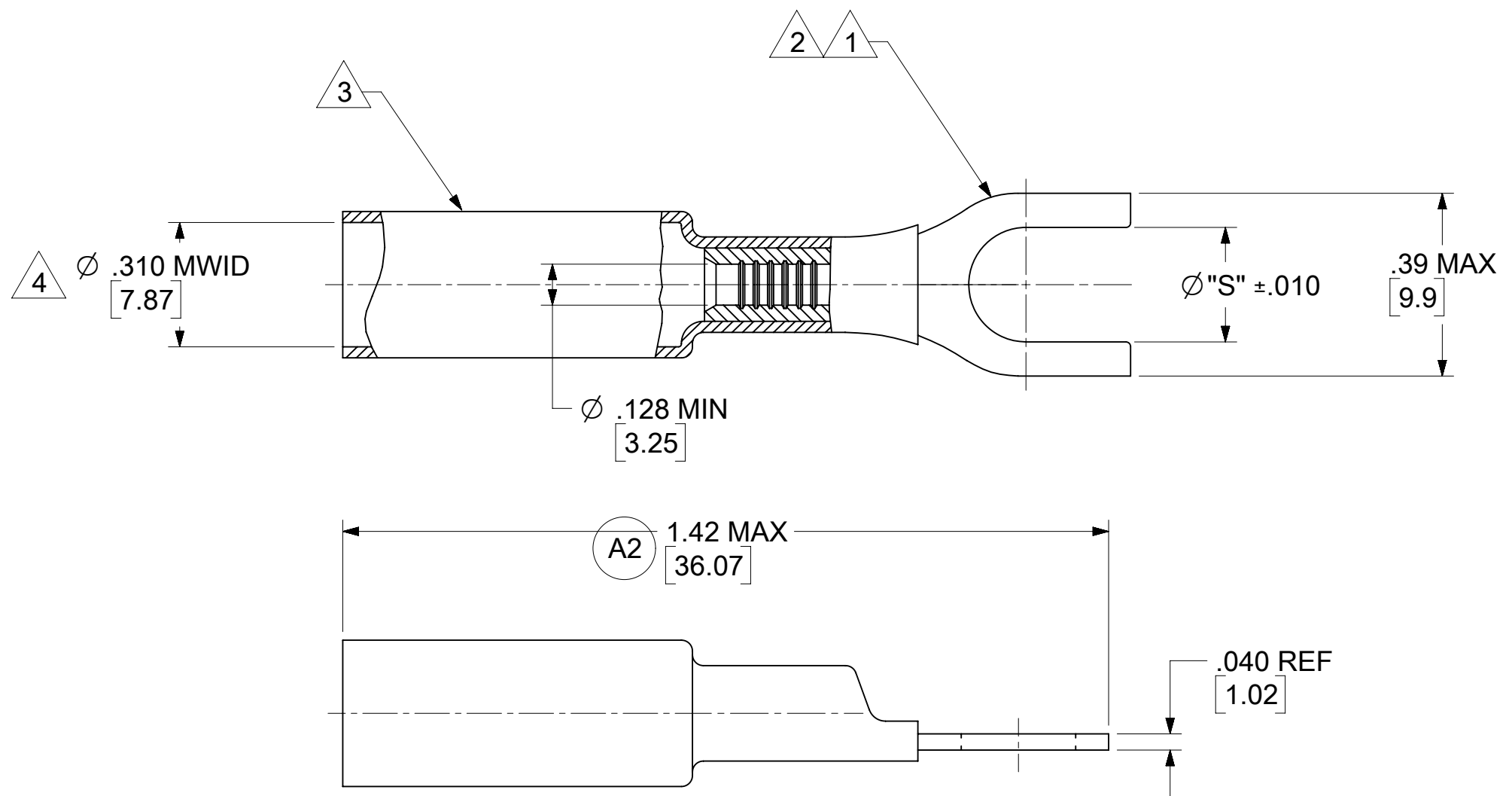

NOTE(S):

- 1 TERMINAL MATERIAL: COPPER ALLOY
- 2 FINISH: ELCTRO TIN PLATE
- 3 INSULATION MATERIAL: HEAT SHRINKABLE TUBING WITH HOTMELT ADHESIVE INNER LINER.
COLOR: YELLOW
- 4 MWID = MAXIMUM WIRE INSULATION DIAMETER.
- 5. PARTS ARE RoHS COMPLIANT.

| | | | | | | | | | | | | | | | | | | | | | | | |
|---|-----------------|-------|--|---------|--------|-----------------|----------------|-----------------|----------|---------------------------------------|--|------------|---------|------------|---------|------------|---------|-----------|---------|------------|---------|-----------------|--|
| THIS DRAWING CONTAINS INFORMATION THAT IS PROPRIETARY TO MOLEX ELECTRONIC TECHNOLOGIES, LLC AND SHOULD NOT BE USED WITHOUT WRITTEN PERMISSION | | | | | | | | | | | | | | | | | | | | | | | |
| FUNCTIONAL SYMBOLS | DIMENSION UNITS | SCALE | CURRENT REV DESC: OAL DIM: 1.42 WAS 1.39 | | | | | | | | | | | | | | | | | | | | |
| $\nabla_A = 0$ | INCH/MM | NTS | <table border="0"> <tr> <td colspan="2">GENERAL TOLERANCES (UNLESS SPECIFIED)</td> </tr> <tr> <td>4 PLACES ±</td> <td>MM INCH</td> </tr> <tr> <td>3 PLACES ±</td> <td>MM INCH</td> </tr> <tr> <td>2 PLACES ±</td> <td>MM INCH</td> </tr> <tr> <td>1 PLACE ±</td> <td>MM INCH</td> </tr> <tr> <td>0 PLACES ±</td> <td>MM INCH</td> </tr> <tr> <td>ANGULAR TOL ± °</td> <td></td> </tr> </table> | | | | | | | GENERAL TOLERANCES (UNLESS SPECIFIED) | | 4 PLACES ± | MM INCH | 3 PLACES ± | MM INCH | 2 PLACES ± | MM INCH | 1 PLACE ± | MM INCH | 0 PLACES ± | MM INCH | ANGULAR TOL ± ° | |
| GENERAL TOLERANCES (UNLESS SPECIFIED) | | | | | | | | | | | | | | | | | | | | | | | |
| 4 PLACES ± | MM INCH | | | | | | | | | | | | | | | | | | | | | | |
| 3 PLACES ± | MM INCH | | | | | | | | | | | | | | | | | | | | | | |
| 2 PLACES ± | MM INCH | | | | | | | | | | | | | | | | | | | | | | |
| 1 PLACE ± | MM INCH | | | | | | | | | | | | | | | | | | | | | | |
| 0 PLACES ± | MM INCH | | | | | | | | | | | | | | | | | | | | | | |
| ANGULAR TOL ± ° | | | | | | | | | | | | | | | | | | | | | | | |
| DIVISIONAL SYMBOLS | | | | | | | | | | | | | | | | | | | | | | | |
| DRAFT WHERE APPLICABLE MUST REMAIN WITHIN DIMENSIONS | | | THIRD ANGLE PROJECTION | DRAWING | SERIES | MATERIAL NUMBER | CUSTOMER | DOCUMENT NUMBER | DOC TYPE | | | | | | | | | | | | | | |
| | | | | B-SIZE | 19164 | | GENERAL MARKET | SD-19164-048 | PSD | | | | | | | | | | | | | | |
| | | | | | | | | DOC PART | REVISION | | | | | | | | | | | | | | |
| | | | | | | | | 001 | A2 | | | | | | | | | | | | | | |
| | | | | | | | | SHEET NUMBER | | | | | | | | | | | | | | | |
| | | | | | | | | 1 OF 1 | | | | | | | | | | | | | | | |