

# FREE HANGING PLUG PARTS

| PART NUMBER | CIRCUIT SIZE | DIM 'A' | COLOR   | TYPE         |
|-------------|--------------|---------|---------|--------------|
| 216945-3004 | 4            | 8.0     | BLACK   | FREE HANGING |
| 216945-3006 | 6            | 11.5    |         |              |
| 216945-3008 | 8            | 15.0    |         |              |
| 216945-3010 | 10           | 18.5    |         |              |
| 216945-3012 | 12           | 22.0    |         |              |
| 216945-3014 | 14           | 25.5    |         |              |
| 216945-3016 | 16           | 29.0    | NATURAL |              |
| 216945-4004 | 4            | 8.0     |         |              |
| 216945-4006 | 6            | 11.5    |         |              |
| 216945-4008 | 8            | 15.0    |         |              |
| 216945-4010 | 10           | 18.5    |         |              |
| 216945-4012 | 12           | 22.0    |         |              |
| 216945-4014 | 14           | 25.5    |         |              |
| 216945-4016 | 16           | 29.0    |         |              |

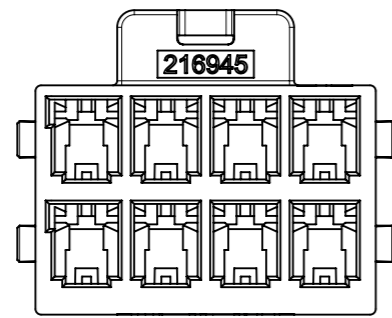
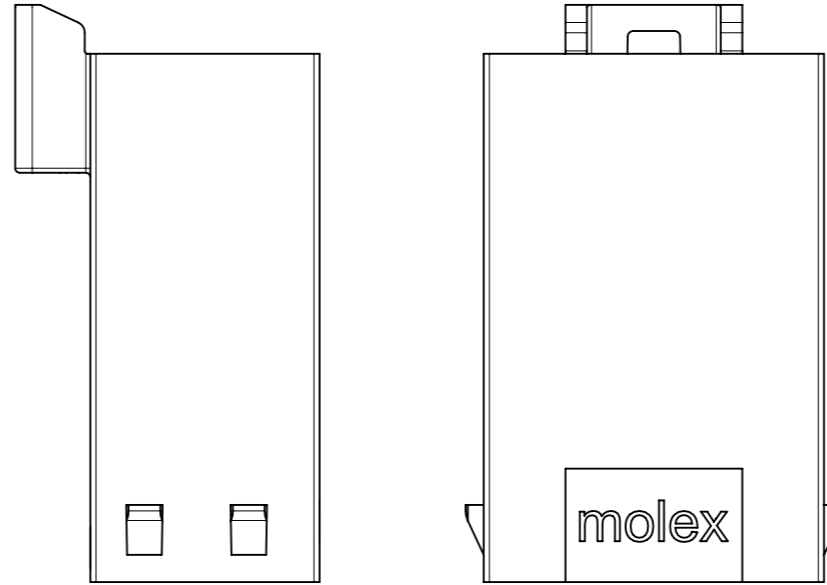
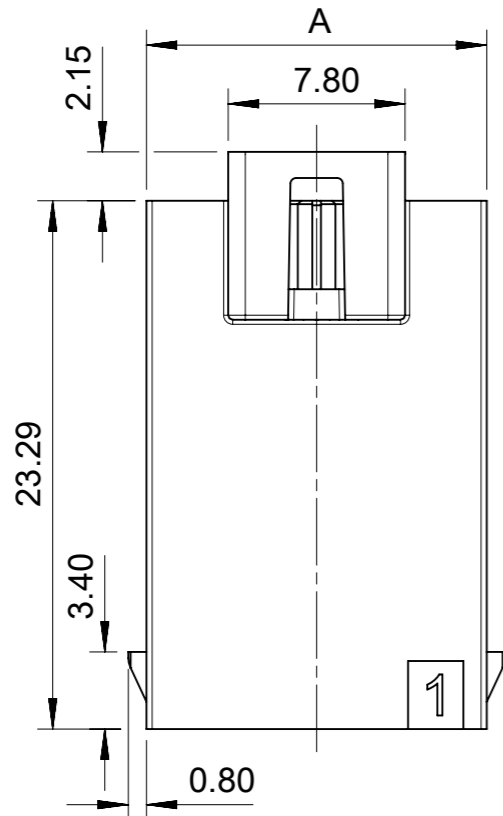

| COLOR FEATURE                      |                                      |
|------------------------------------|--------------------------------------|
| BLACK                              | NATURAL                              |
| <p>KEY A FOR BLACK COLOR PARTS</p> | <p>KEY B FOR NATURAL COLOR PARTS</p> |

- NOTES:
1. MATERIAL: PA66, 94V-0, BLACK AND NATURAL.
  2. PRODUCT SPECIFICATION: 2169461000-PS.
  3. PACKAGE SPECIFICATION: 2169451000-PK.
  4. TO USE WITH TERMINAL OF 216946-\*\*\*\*.
  5. TO USE WITH TPA OF 172264-\*\*\*\*.
  6. TO MATE WITH RECEPTACLE OF 172258-\*\*\*\*.
  7. PARTS CONFORM TO CLASS 'B' REQUIREMENTS OF COSMETIC SPECIFICATION PS-45499-002.

|                                                                                                                                               |  |                        |  |                           |  |        |  |                                                  |  |
|-----------------------------------------------------------------------------------------------------------------------------------------------|--|------------------------|--|---------------------------|--|--------|--|--------------------------------------------------|--|
| THIS DRAWING CONTAINS INFORMATION THAT IS PROPRIETARY TO MOLEX ELECTRONIC TECHNOLOGIES, LLC AND SHOULD NOT BE USED WITHOUT WRITTEN PERMISSION |  |                        |  |                           |  |        |  |                                                  |  |
| DIMENSION UNITS                                                                                                                               |  | SCALE                  |  | CURRENT REV DESC:         |  |        |  |                                                  |  |
| mm                                                                                                                                            |  | NTS                    |  |                           |  |        |  |                                                  |  |
| GENERAL TOLERANCES (UNLESS SPECIFIED)                                                                                                         |  |                        |  | EC NO: 726545             |  |        |  | PLUG HOUSING OF ULTRA-FIT WTW DR POWER CONNECTOR |  |
| ANGULAR TOL ± °                                                                                                                               |  |                        |  | DRWN: LEOW 2022/10/31     |  |        |  |                                                  |  |
| 4 PLACES ±                                                                                                                                    |  |                        |  | CHK'D: EDUGGER 2022/11/01 |  |        |  | PRODUCT CUSTOMER DRAWING                         |  |
| 3 PLACES ±                                                                                                                                    |  |                        |  | APPR: EDUGGER 2022/11/01  |  |        |  |                                                  |  |
| 2 PLACES ± 0.2                                                                                                                                |  |                        |  | INITIAL REVISION:         |  |        |  | DOCUMENT NUMBER: 2169451000-SD                   |  |
| 1 PLACE ±                                                                                                                                     |  |                        |  | DRWN: GLLI 2021/07/06     |  |        |  |                                                  |  |
| 0 PLACES ±                                                                                                                                    |  |                        |  | APPR: EDUGGER 2022/11/01  |  |        |  | DOC TYPE: PSD                                    |  |
| DRAFT WHERE APPLICABLE MUST REMAIN WITHIN DIMENSIONS                                                                                          |  | THIRD ANGLE PROJECTION |  | DRAWING                   |  | SERIES |  | SHEET NUMBER                                     |  |
|                                                                                                                                               |  |                        |  | A3-SIZE                   |  | 216945 |  | 1 OF 6                                           |  |

# FREE HANGING PLUG PARTS

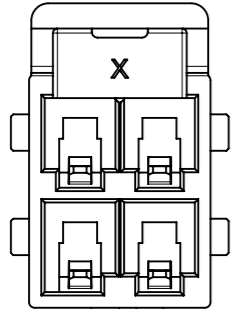

4CKT

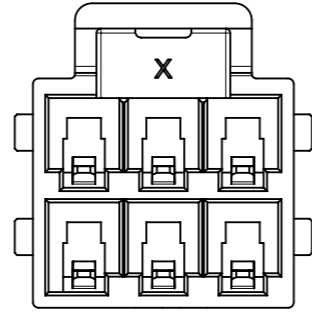

6CKT

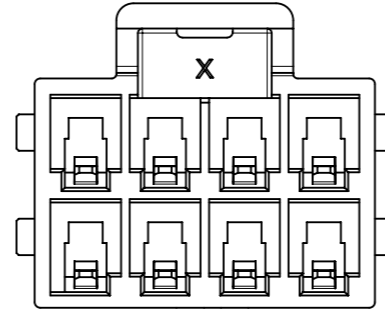

8CKT

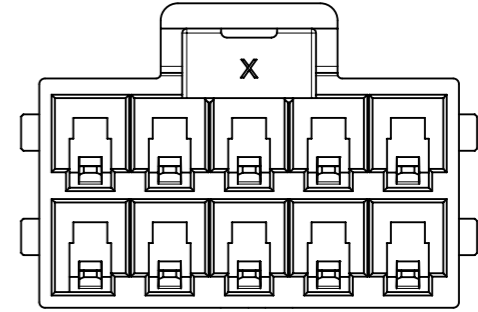

10CKT

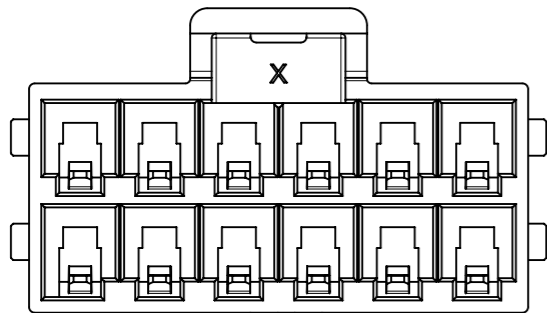

12CKT

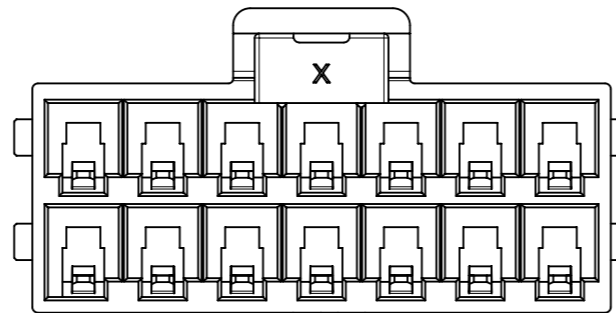

14CKT

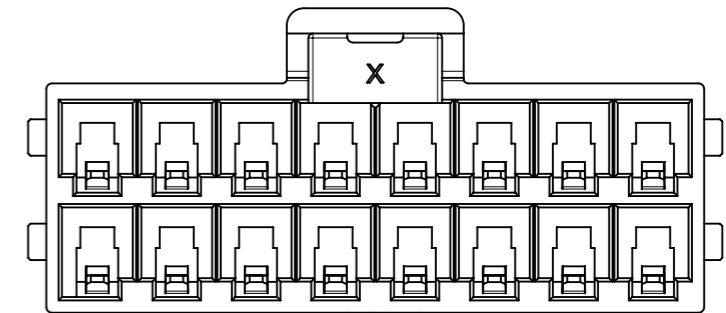

16CKT

|                                                                                                                                               |       |                        |            |        |                 |                                       |                                                  |  |  |  |
|-----------------------------------------------------------------------------------------------------------------------------------------------|-------|------------------------|------------|--------|-----------------|---------------------------------------|--------------------------------------------------|--|--|--|
| THIS DRAWING CONTAINS INFORMATION THAT IS PROPRIETARY TO MOLEX ELECTRONIC TECHNOLOGIES, LLC AND SHOULD NOT BE USED WITHOUT WRITTEN PERMISSION |       |                        |            |        |                 |                                       |                                                  |  |  |  |
| DIMENSION UNITS                                                                                                                               | SCALE | CURRENT REV DESC:      |            |        |                 |                                       | <b>molex</b>                                     |  |  |  |
| mm                                                                                                                                            | NTS   |                        |            |        |                 |                                       |                                                  |  |  |  |
| GENERAL TOLERANCES (UNLESS SPECIFIED)                                                                                                         |       |                        |            |        |                 |                                       | PLUG HOUSING OF ULTRA-FIT WTW DR POWER CONNECTOR |  |  |  |
| ANGULAR TOL ± °                                                                                                                               |       |                        |            |        |                 |                                       | PRODUCT CUSTOMER DRAWING                         |  |  |  |
| 4 PLACES                                                                                                                                      | ±     | EC NO: 726545          |            |        |                 | DOCUMENT NUMBER                       |                                                  |  |  |  |
| 3 PLACES                                                                                                                                      | ±     | DRWN: LEOW             | 2022/10/31 |        |                 | 2169451000-SD                         |                                                  |  |  |  |
| 2 PLACES                                                                                                                                      | ± 0.2 | CHK'D: EDUGGER         | 2022/11/01 |        |                 | DOC TYPE DOC PART REVISION            |                                                  |  |  |  |
| 1 PLACE                                                                                                                                       | ±     | APPR: EDUGGER          | 2022/11/01 |        |                 | PSD 000 A                             |                                                  |  |  |  |
| 0 PLACES                                                                                                                                      | ±     | INITIAL REVISION:      |            |        |                 | MATERIAL NUMBER CUSTOMER SHEET NUMBER |                                                  |  |  |  |
| DRAFT WHERE APPLICABLE MUST REMAIN WITHIN DIMENSIONS                                                                                          |       | THIRD ANGLE PROJECTION | DRAWING    | SERIES | MATERIAL NUMBER | CUSTOMER                              | SHEET NUMBER                                     |  |  |  |
|                                                                                                                                               |       |                        | A3-SIZE    | 216945 | SEE TABLE       | GENERAL MARKET                        | 2 OF 6                                           |  |  |  |

|                 |    |              |            |          |
|-----------------|----|--------------|------------|----------|
| DOCUMENT STATUS | P1 | RELEASE DATE | 2022/11/01 | 13:33:31 |
|-----------------|----|--------------|------------|----------|

# FREE HANGING PLUG PARTS

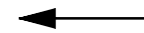
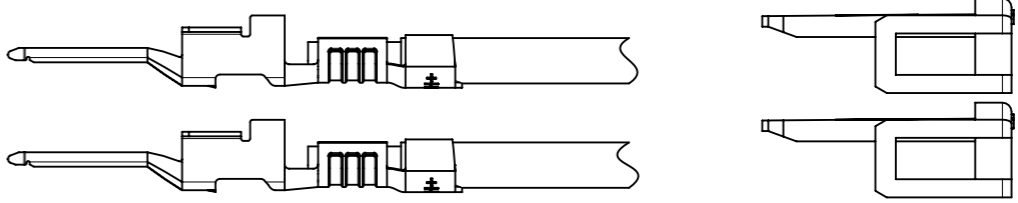
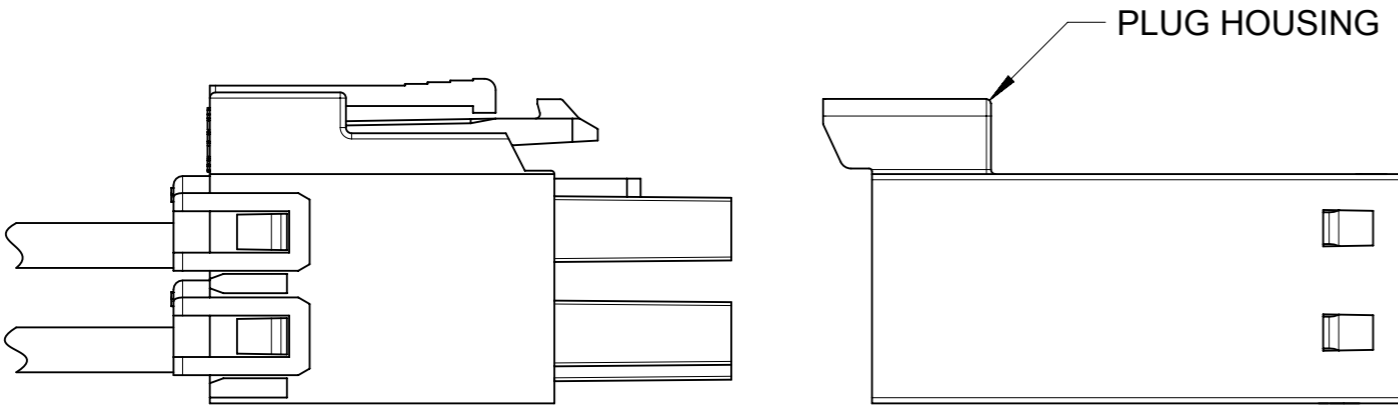
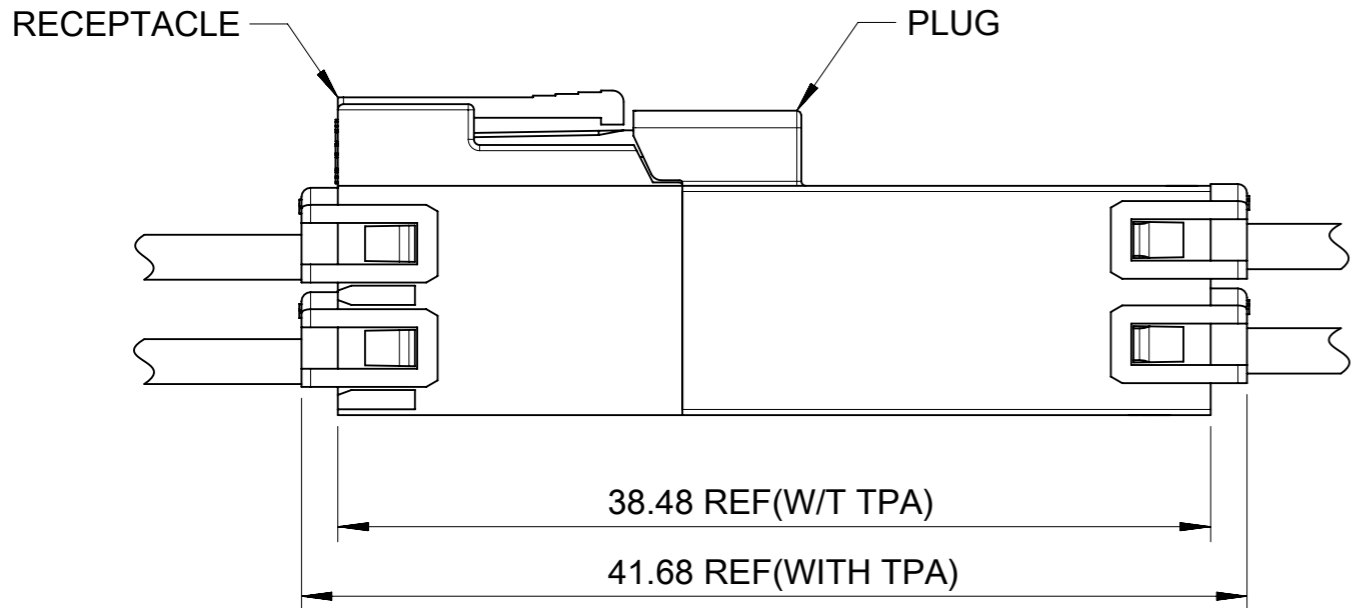

PLUG TERMINAL AND TPA ORIENTATION

|                                                                                                                                               |  |       |  |                                                                                                                                                                           |  |                |  |                                                  |  |          |  |          |  |
|-----------------------------------------------------------------------------------------------------------------------------------------------|--|-------|--|---------------------------------------------------------------------------------------------------------------------------------------------------------------------------|--|----------------|--|--------------------------------------------------|--|----------|--|----------|--|
| THIS DRAWING CONTAINS INFORMATION THAT IS PROPRIETARY TO MOLEX ELECTRONIC TECHNOLOGIES, LLC AND SHOULD NOT BE USED WITHOUT WRITTEN PERMISSION |  |       |  |                                                                                                                                                                           |  |                |  |                                                  |  |          |  |          |  |
| DIMENSION UNITS                                                                                                                               |  | SCALE |  | CURRENT REV DESC:                                                                                                                                                         |  |                |  | <b>molex</b>                                     |  |          |  |          |  |
| mm                                                                                                                                            |  | NTS   |  |                                                                                                                                                                           |  |                |  |                                                  |  |          |  |          |  |
| GENERAL TOLERANCES (UNLESS SPECIFIED)                                                                                                         |  |       |  | EC NO: 726545<br>DRWN: LEOW 2022/10/31<br>CHK'D: EDUGGER 2022/11/01<br>APPR: EDUGGER 2022/11/01<br>INITIAL REVISION:<br>DRWN: GLLI 2021/07/06<br>APPR: EDUGGER 2022/11/01 |  |                |  | PLUG HOUSING OF ULTRA-FIT WTW DR POWER CONNECTOR |  |          |  |          |  |
| ANGULAR TOL ± °                                                                                                                               |  |       |  |                                                                                                                                                                           |  |                |  | PRODUCT CUSTOMER DRAWING                         |  |          |  |          |  |
| 4 PLACES ±                                                                                                                                    |  |       |  |                                                                                                                                                                           |  |                |  | DOCUMENT NUMBER                                  |  | DOC TYPE |  | DOC PART |  |
| 3 PLACES ±                                                                                                                                    |  |       |  |                                                                                                                                                                           |  |                |  | 2169451000-SD                                    |  | PSD      |  | 000      |  |
| 2 PLACES ±                                                                                                                                    |  | 0.2   |  |                                                                                                                                                                           |  |                |  | REVISION                                         |  | A        |  |          |  |
| 1 PLACE ±                                                                                                                                     |  |       |  | MATERIAL NUMBER                                                                                                                                                           |  | CUSTOMER       |  | SHEET NUMBER                                     |  |          |  |          |  |
| 0 PLACES ±                                                                                                                                    |  |       |  | SEE TABLE                                                                                                                                                                 |  | GENERAL MARKET |  | 3 OF 6                                           |  |          |  |          |  |
| DRAFT WHERE APPLICABLE MUST REMAIN WITHIN DIMENSIONS                                                                                          |  |       |  | THIRD ANGLE PROJECTION                                                                                                                                                    |  | DRAWING        |  | SERIES                                           |  |          |  |          |  |
|                                                                                                                                               |  |       |  |                                                                                                                                                                           |  | A3-SIZE        |  | 216945                                           |  |          |  |          |  |

# PANEL MOUNT PLUG PARTS

| PART NUMBER | CIRCUIT SIZE | DIM 'A' | DIM 'B' | COLOR   | TYPE        |
|-------------|--------------|---------|---------|---------|-------------|
| 216945-3104 | 4            | 8.0     | 16.92   | BLACK   | PANEL MOUNT |
| 216945-3106 | 6            | 11.5    | 20.42   |         |             |
| 216945-3108 | 8            | 15.0    | 23.92   |         |             |
| 216945-3110 | 10           | 18.5    | 27.42   |         |             |
| 216945-3112 | 12           | 22.0    | 30.92   |         |             |
| 216945-3114 | 14           | 25.5    | 34.42   |         |             |
| 216945-4104 | 4            | 8.0     | 16.92   | NATURAL |             |
| 216945-4106 | 6            | 11.5    | 20.42   |         |             |
| 216945-4108 | 8            | 15.0    | 23.92   |         |             |
| 216945-4110 | 10           | 18.5    | 27.42   |         |             |
| 216945-4112 | 12           | 22.0    | 30.92   |         |             |
| 216945-4114 | 14           | 25.5    | 34.42   |         |             |
| 216945-4116 | 16           | 29.0    | 37.92   |         |             |

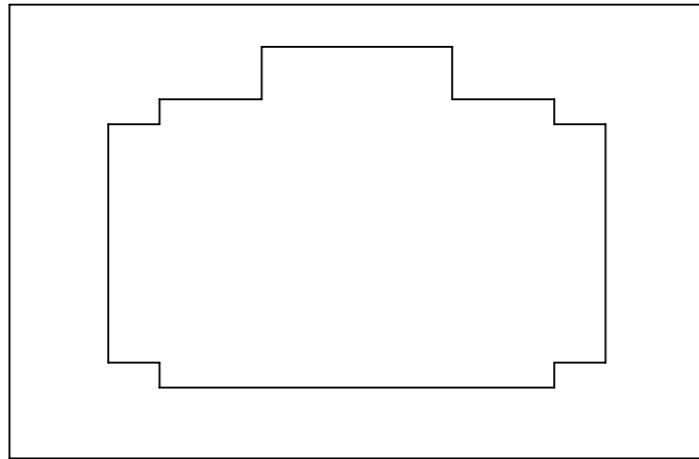
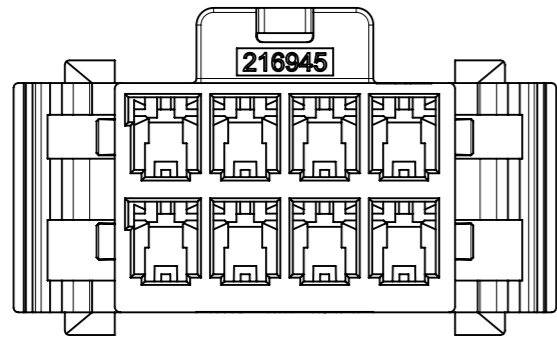
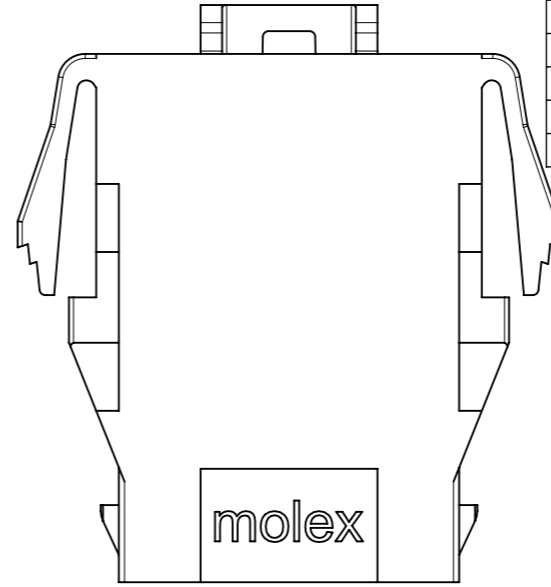
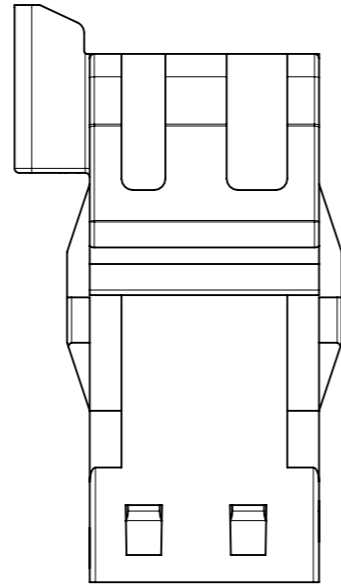
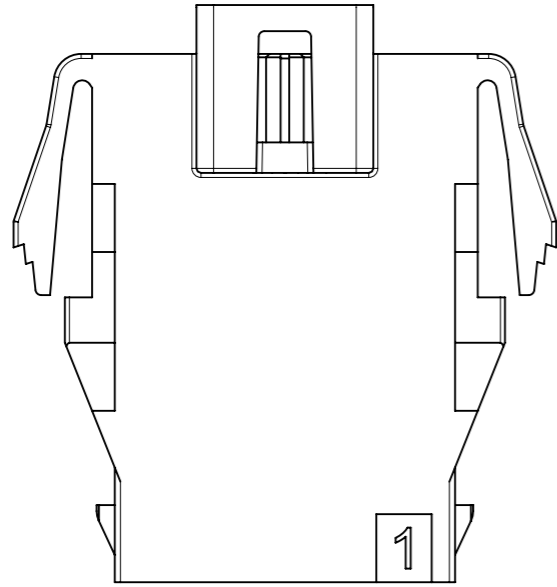

| COLOR FEATURE                      |                                      |
|------------------------------------|--------------------------------------|
| BLACK                              | NATURAL                              |
| <p>KEY A FOR BLACK COLOR PARTS</p> | <p>KEY B FOR NATURAL COLOR PARTS</p> |

|                                                                                                                                               |       |                                                                                         |            |        |                 |                |              |          |          |
|-----------------------------------------------------------------------------------------------------------------------------------------------|-------|-----------------------------------------------------------------------------------------|------------|--------|-----------------|----------------|--------------|----------|----------|
| THIS DRAWING CONTAINS INFORMATION THAT IS PROPRIETARY TO MOLEX ELECTRONIC TECHNOLOGIES, LLC AND SHOULD NOT BE USED WITHOUT WRITTEN PERMISSION |       |                                                                                         |            |        |                 |                |              |          |          |
| DIMENSION UNITS                                                                                                                               | SCALE | CURRENT REV DESC:                                                                       |            |        |                 |                |              |          |          |
| mm                                                                                                                                            | NTS   | <p>PLUG HOUSING OF ULTRA-FIT WTW DR POWER CONNECTOR</p> <p>PRODUCT CUSTOMER DRAWING</p> |            |        |                 |                |              |          |          |
| GENERAL TOLERANCES (UNLESS SPECIFIED)                                                                                                         |       |                                                                                         |            |        |                 |                |              |          |          |
| ANGULAR TOL                                                                                                                                   | ± °   |                                                                                         |            |        |                 |                |              |          |          |
| 4 PLACES                                                                                                                                      | ±     |                                                                                         |            |        |                 |                |              |          |          |
| 3 PLACES                                                                                                                                      | ±     |                                                                                         |            |        |                 |                |              |          |          |
| 2 PLACES                                                                                                                                      | ± 0.2 |                                                                                         |            |        |                 |                |              |          |          |
| 1 PLACE                                                                                                                                       | ±     | EC NO: 726545                                                                           | 2022/10/31 |        | DOCUMENT NUMBER |                |              |          |          |
| 0 PLACES                                                                                                                                      | ±     | DRWN: LEOW                                                                              | 2022/11/01 |        | 2169451000-SD   |                | DOC TYPE     | DOC PART | REVISION |
| DRAFT WHERE APPLICABLE MUST REMAIN WITHIN DIMENSIONS                                                                                          |       | THIRD ANGLE PROJECTION                                                                  | DRAWING    | SERIES | MATERIAL NUMBER | CUSTOMER       | SHEET NUMBER |          |          |
|                                                                                                                                               |       |                                                                                         | A3-SIZE    | 216945 | SEE TABLE       | GENERAL MARKET | 4 OF 6       |          |          |

# PANEL MOUNT PLUG PARTS

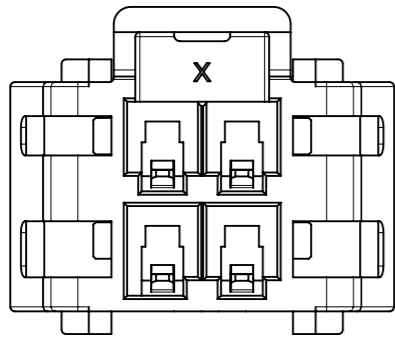

4 CKT

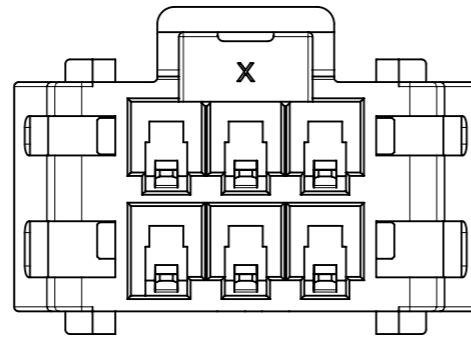

6 CKT

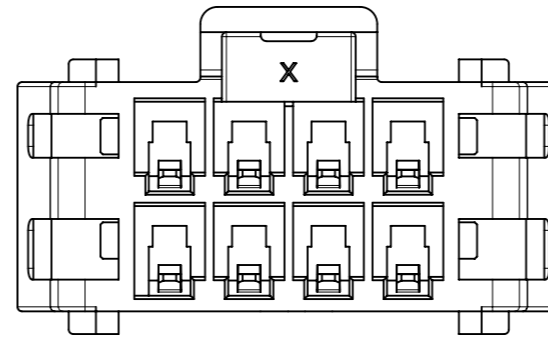

8 CKT

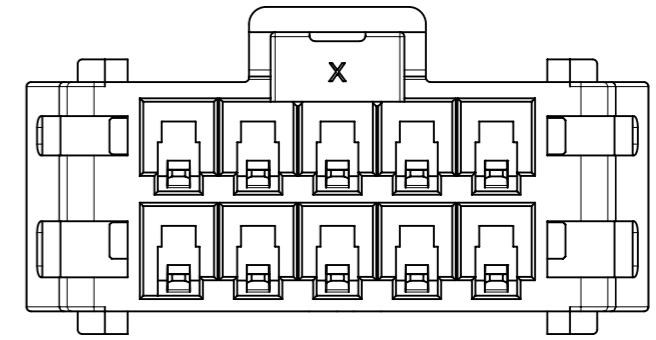

10 CKT

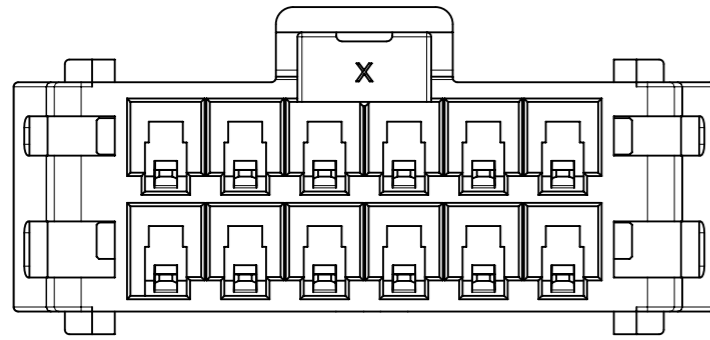

12 CKT

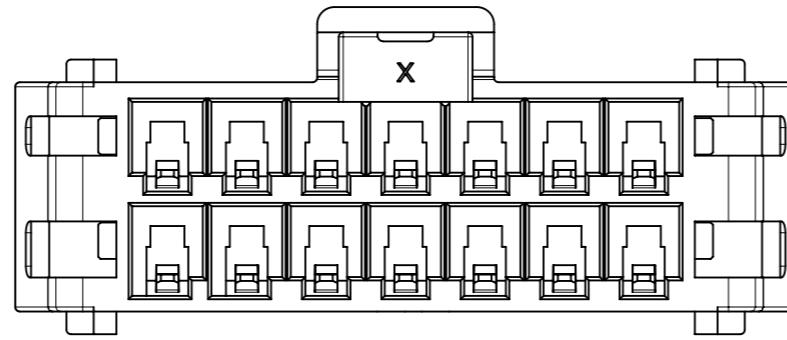

14 CKT

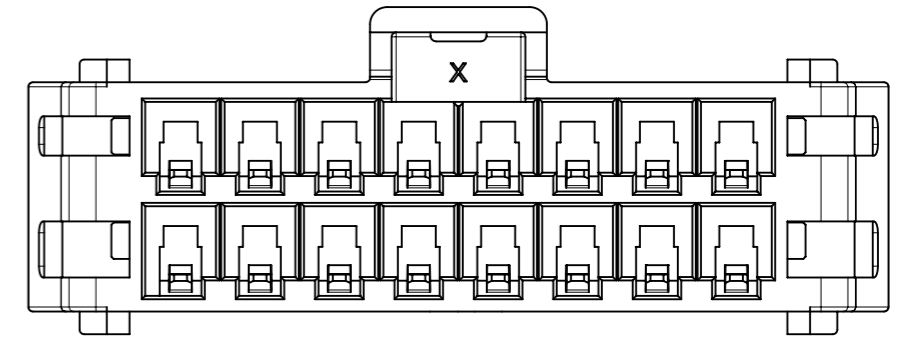

16 CKT

|                                                                                                                                               |       |                        |  |         |                                                  |        |  |                 |  |                |  |              |  |
|-----------------------------------------------------------------------------------------------------------------------------------------------|-------|------------------------|--|---------|--------------------------------------------------|--------|--|-----------------|--|----------------|--|--------------|--|
| THIS DRAWING CONTAINS INFORMATION THAT IS PROPRIETARY TO MOLEX ELECTRONIC TECHNOLOGIES, LLC AND SHOULD NOT BE USED WITHOUT WRITTEN PERMISSION |       |                        |  |         |                                                  |        |  |                 |  |                |  |              |  |
| DIMENSION UNITS                                                                                                                               | SCALE | CURRENT REV DESC:      |  |         |                                                  |        |  |                 |  |                |  |              |  |
| mm                                                                                                                                            | NTS   |                        |  |         |                                                  |        |  |                 |  |                |  |              |  |
| GENERAL TOLERANCES (UNLESS SPECIFIED)                                                                                                         |       | EC NO: 726545          |  |         | PLUG HOUSING OF ULTRA-FIT WTW DR POWER CONNECTOR |        |  |                 |  |                |  |              |  |
| ANGULAR TOL                                                                                                                                   | ±     | °                      |  |         | PRODUCT CUSTOMER DRAWING                         |        |  |                 |  |                |  |              |  |
| 4 PLACES                                                                                                                                      | ±     | DRWN: LEOW             |  |         | 2022/10/31                                       |        |  |                 |  |                |  |              |  |
| 3 PLACES                                                                                                                                      | ±     | CHK'D: EDUGGER         |  |         | 2022/11/01                                       |        |  |                 |  |                |  |              |  |
| 2 PLACES                                                                                                                                      | ±     | APPR: EDUGGER          |  |         | 2022/11/01                                       |        |  |                 |  |                |  |              |  |
| 1 PLACE                                                                                                                                       | ±     | INITIAL REVISION:      |  |         | DOCUMENT NUMBER                                  |        |  |                 |  |                |  |              |  |
| 0 PLACES                                                                                                                                      | ±     | DRWN: GLLI             |  |         | 2021/07/06                                       |        |  |                 |  |                |  |              |  |
| DRAFT WHERE APPLICABLE MUST REMAIN WITHIN DIMENSIONS                                                                                          |       | THIRD ANGLE PROJECTION |  | DRAWING |                                                  | SERIES |  | MATERIAL NUMBER |  | CUSTOMER       |  | SHEET NUMBER |  |
|                                                                                                                                               |       |                        |  | A3-SIZE |                                                  | 216945 |  | 2169451000-SD   |  | GENERAL MARKET |  | 5 OF 6       |  |

# PANEL MOUNT PLUG PARTS

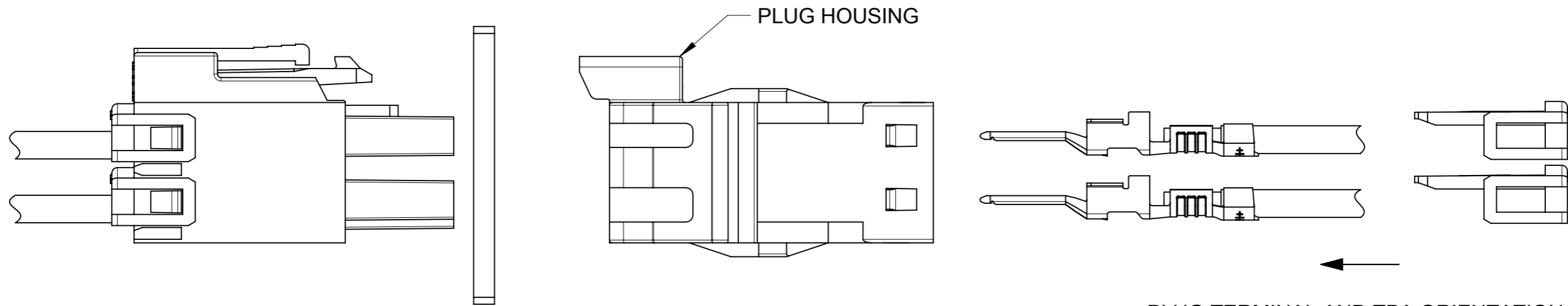
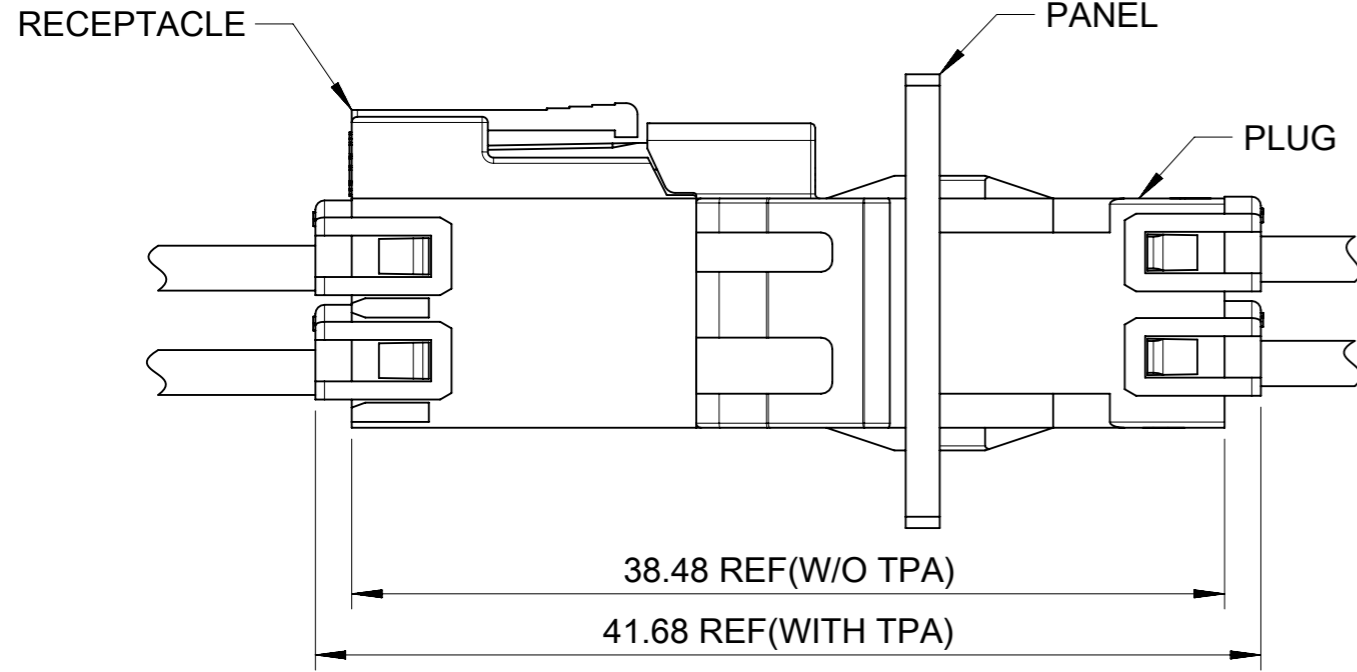

|                                                                                                                                               |  |       |  |                                                                                                                                                                           |  |                |  |                                                  |  |          |  |              |  |
|-----------------------------------------------------------------------------------------------------------------------------------------------|--|-------|--|---------------------------------------------------------------------------------------------------------------------------------------------------------------------------|--|----------------|--|--------------------------------------------------|--|----------|--|--------------|--|
| THIS DRAWING CONTAINS INFORMATION THAT IS PROPRIETARY TO MOLEX ELECTRONIC TECHNOLOGIES, LLC AND SHOULD NOT BE USED WITHOUT WRITTEN PERMISSION |  |       |  |                                                                                                                                                                           |  |                |  |                                                  |  |          |  |              |  |
| DIMENSION UNITS                                                                                                                               |  | SCALE |  | CURRENT REV DESC:                                                                                                                                                         |  |                |  | <b>molex</b>                                     |  |          |  |              |  |
| mm                                                                                                                                            |  | NTS   |  |                                                                                                                                                                           |  |                |  |                                                  |  |          |  |              |  |
| GENERAL TOLERANCES (UNLESS SPECIFIED)                                                                                                         |  |       |  | EC NO: 726545<br>DRWN: LEOW 2022/10/31<br>CHK'D: EDUGGER 2022/11/01<br>APPR: EDUGGER 2022/11/01<br>INITIAL REVISION:<br>DRWN: GLLI 2021/07/06<br>APPR: EDUGGER 2022/11/01 |  |                |  | PLUG HOUSING OF ULTRA-FIT WTW DR POWER CONNECTOR |  |          |  |              |  |
| ANGULAR TOL ± °                                                                                                                               |  |       |  |                                                                                                                                                                           |  |                |  | PRODUCT CUSTOMER DRAWING                         |  |          |  |              |  |
| 4 PLACES ±                                                                                                                                    |  |       |  |                                                                                                                                                                           |  |                |  | DOCUMENT NUMBER                                  |  | DOC TYPE |  | DOC PART     |  |
| 3 PLACES ±                                                                                                                                    |  |       |  |                                                                                                                                                                           |  |                |  | 2169451000-SD                                    |  | PSD      |  | 000          |  |
| 2 PLACES ± 0.2                                                                                                                                |  |       |  |                                                                                                                                                                           |  |                |  | REVISION                                         |  |          |  | A            |  |
| 1 PLACE ±                                                                                                                                     |  |       |  |                                                                                                                                                                           |  |                |  | MATERIAL NUMBER                                  |  | CUSTOMER |  | SHEET NUMBER |  |
| 0 PLACES ±                                                                                                                                    |  |       |  | SEE TABLE                                                                                                                                                                 |  | GENERAL MARKET |  | 6 OF 6                                           |  |          |  |              |  |
| DRAFT WHERE APPLICABLE MUST REMAIN WITHIN DIMENSIONS                                                                                          |  |       |  | THIRD ANGLE PROJECTION                                                                                                                                                    |  | DRAWING        |  | SERIES                                           |  |          |  |              |  |
|                                                                                                                                               |  |       |  |                                                                                                                                                                           |  | A3-SIZE        |  | 216945                                           |  |          |  |              |  |

|                 |    |              |            |          |
|-----------------|----|--------------|------------|----------|
| DOCUMENT STATUS | P1 | RELEASE DATE | 2022/11/01 | 13:33:31 |
|-----------------|----|--------------|------------|----------|