

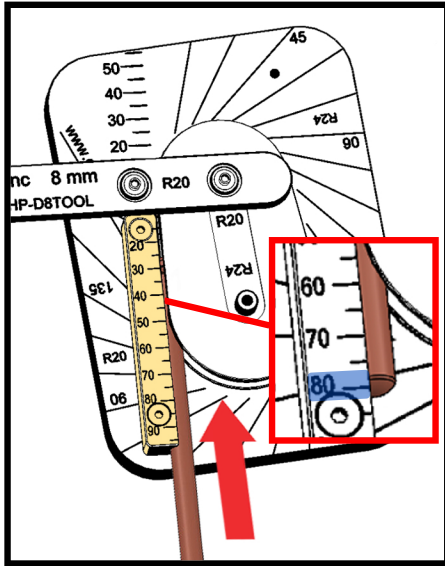

ATS-HP-DTOOL QUICK START GUIDE*

* This guide uses the ATS-HP-D8TOOL and its two radius options only as a reference. The following operation procedures apply to all ATS-HP-DTOOL models.



① Insert the heat pipe and set it at the bending point using the **primary scale** (the drawing shows a bend point **80mm** from the end of the heat pipe.)

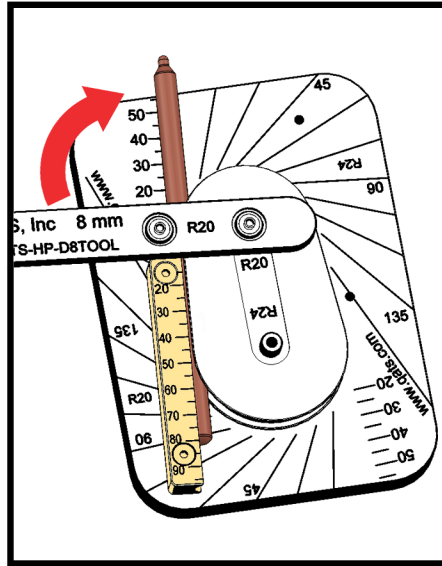

② Applying steady pressure, move the handle clockwise to begin the bending process.

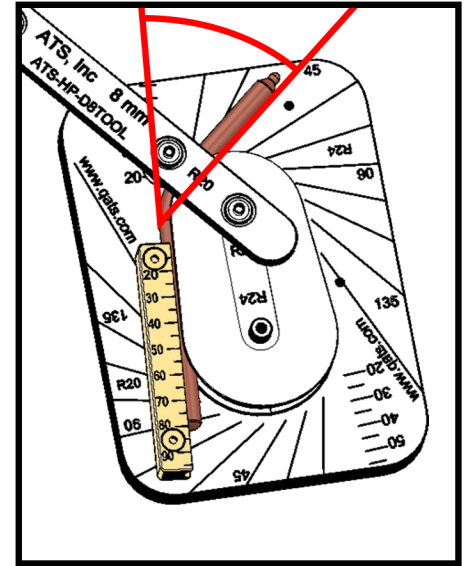

③ Bend the heat pipe until it reaches the desired bend angle (45 degrees in drawing). Then remove the heat pipe.

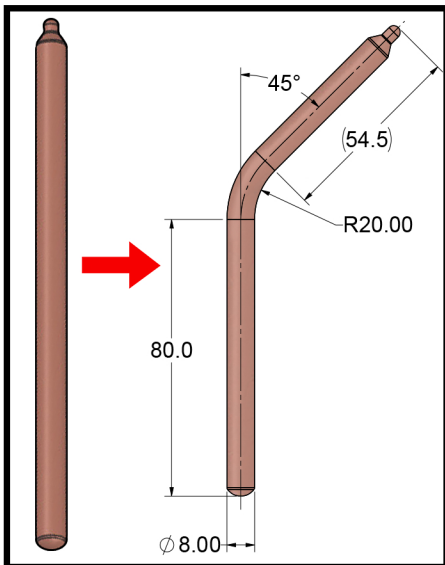

④ As seen in the drawing above, the heat pipe now has a 45° angle bend 80mm from the end of the heat pipe around a radius of 20mm.

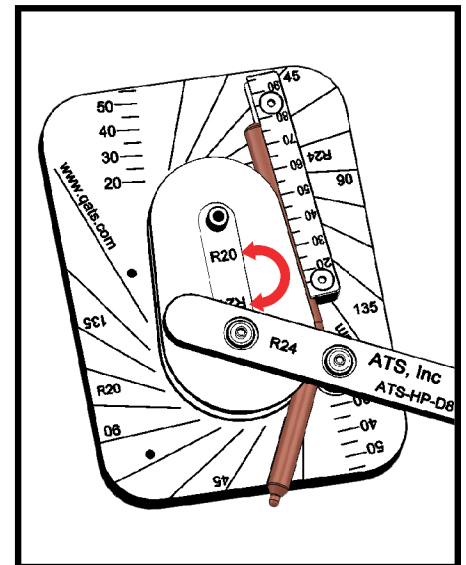
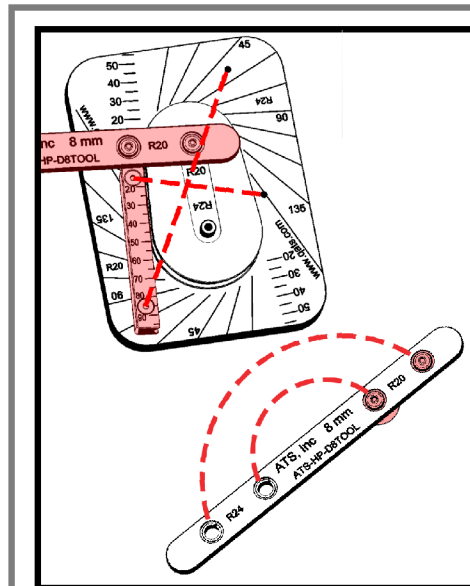

Reconfiguration Procedure

To use the secondary bend radius tool, first remove and reattach the lower bend point scale to the opposite side. Then Remove the bending handle and move the roller to the opposite position. Reattach the handle on the R24 side to complete the process.

For an instructional video and more information scan the QR code or visit www.qats.com/Products/Heat-Pipes

