

Protective covers - HC-STA-D50-BCSFD-PL-BK - 1424417

Please be informed that the data shown in this PDF Document is generated from our Online Catalog. Please find the complete data in the user's documentation. Our General Terms of Use for Downloads are valid (<http://phoenixcontact.com/download>)

Protective cover D50, for double locking latch, protective cover material: PA, height: 19 mm, seal: no, Standard



COMPLIANT

Key Commercial Data

Packing unit	1 pc
GTIN	 4 055626 371573
GTIN	4055626371573

Technical data

Dimensions

Height	19 mm
Width	60.5 mm
Length	86.5 mm

Ambient conditions

Degree of protection (IP)	IP66
Ambient temperature (operation)	-20 °C ... 100 °C

General

Note	Protective cover for supporting base element with double locking latch
Size	D50
Type	For supporting base element with double locking latch
Housing type	Protective cover
Color	black
Locking type	for double locking latch
Material	PA
Material, protective cover	PA
Flammability rating according to UL 94	V0
Connection	Plastic protective cover for short-term protection

Protective covers - HC-STA-D50-BCSFD-PL-BK - 1424417

Technical data

Standards and Regulations

Flammability rating according to UL 94	V0
--	----

Environmental Product Compliance

China RoHS	Environmentally Friendly Use Period = 50
	For details about hazardous substances go to tab "Downloads", Category "Manufacturer's declaration"

Drawings

Dimensional drawing

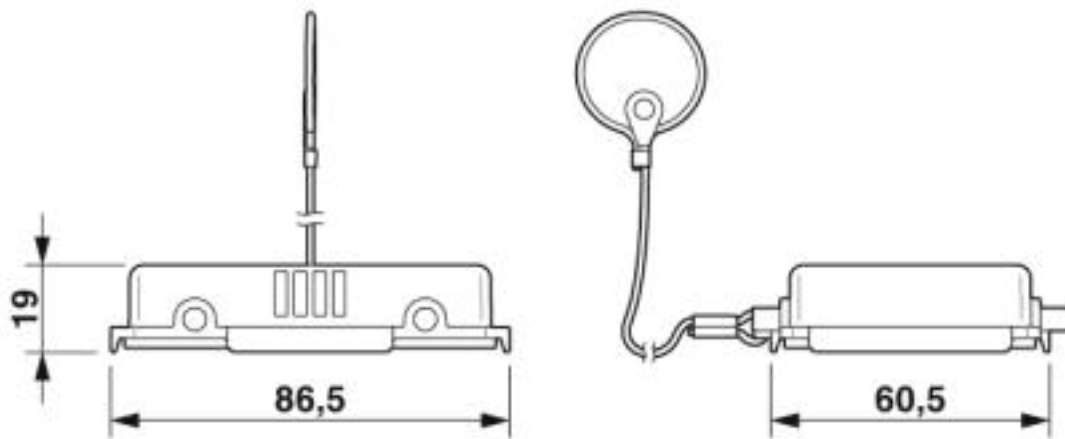

Dimensional drawing

Approvals

Approvals

Approvals

EAC / DNV GL

Ex Approvals

Approval details

EAC		EAC-Zulassung
-----	--	---------------

Protective covers - HC-STA-D50-BCSFD-PL-BK - 1424417

Approvals

DNV GL



<https://approvalfinder.dnvgl.com/>

TAE000037S

Phoenix Contact 2019 © - all rights reserved
<http://www.phoenixcontact.com>

PHOENIX CONTACT GmbH & Co. KG
Flachsmarktstr. 8
32825 Blomberg
Germany
Tel. +49 5235 300
Fax +49 5235 3 41200
<http://www.phoenixcontact.com>