



SPECIFICATION SHEET

SPECIFICATION SHEET NO.	P1116- HBW336M063HFKT
DATE	Nov.16, 2022
REVISION	A0
DESCRIPTION	Conductive Polymer Hybrid Aluminum Electrolytic Capacitors HBW series, Capacitance: 33μF, Tolerance ±20%, Voltage 63V, 2 pads Case size: ØD8.00*L10.2mm, Ripple Current 1100mA Max.@+125°C, 100KHz, Lifetime 4000Hours @125°C, Operating Temp. Range -55°C ~+125°C, Leakage Current :(at 20°C after 2 minutes): 20.8μA, ESR @125°C,100KHz: 40mohm Max. RoHS/RoHS III Compliant & Halogen Free, Package in Tape/Reel,
CUSTOMER	
CUSTOMER PART NUMBER	
CROSS REF. PART NUMBER	
ORIGINAL PART NUMBER	Aillen CXE336M1JHBWF10TR
PART CODE	HBW336M063HFKT

VENDOR APPROVE			
Issued/Checked/Approved			
DATE: Nov.16, 2022			

CUSTOMER APPROVE	
DATE:	

CONDUCTIVE POLYMER HYBRID ALUMINUM ELEC. CAPACITORS HBW SERIES

MAIN FEATURE

- Conductive Polymer Hybrid Aluminum Electrolytic Capacitors
- High Stability And Reliability, Low ESR, High Ripple Current
- Long Life 4000 Hours @ 125°C
- Quality and standard Meets IEC 60384-4 and AEC-Q200-REV D
- Applicable To Automatic Mounting Machine
- Cross Competitors PARTS GYA, HZC, ZC And HXC Series And More.
- RoHS III Complaint And Halogen Free



APPLICATION

- For Applications Automotive and more

PART CODE GUIDE

RFQ
Request For Quotation

HBW	336	M	063	H	F	K	T
1	2	3	4	5	6	7	8

- 1) **HBW**: Conductive Polymer Hybrid Aluminum Electrolytic Capacitors HBW series, 2 Pads
- 2) **336**: Rated Capacitance Code, 105: 1.0µF; 225: 2.2µF; 335: 3.3µF; 475: 4.7µF; 106: 10µF; 226: 22µF; **336: 33µF**; 476: 47µF
107: 100µF; 227: 220µF; 337: 330µF ; 477: 470µF
- 3) **M**: Capacitance tolerance code, **M: ±20%**; V: -10% ~ ±20%,
- 4) **063**: Rated Voltage Code, 016:16V; 025: 25V; 035: 35V; 050: 50V; **063: 63V**; 080: 80V
- 5) **H**: Environmental Requirements code, R: RoHS Complaint; **H: RoHS III Complaint & Halogen Free**
- 6) **F**: Aluminum Case size code, B: ØD3.0mm; C: ØD4.0mm; D: ØD5.0mm; E: ØD6.3mm; **F: ØD8.0mm**; G: ØD10.0mm; P: ØD12.5mm
- 7) **K**: Aluminum case Height code, H: L5.4mm; I: L6.5mm; J: L7.7mm; **K: L10.2mm**; L: L11.5mm; M: L12.5mm; N: L13.5mm
- 8) **T**: Package in Tape/Reel, 500pcs/Reel

CONDUCTIVE POLYMER HYBRID ALUMINUM ELEC. CAPACITORS HBW SERIES

Image For Reference



HBW Series
Case ϕ D8.0*L10.2mm
Explosion Proof Value

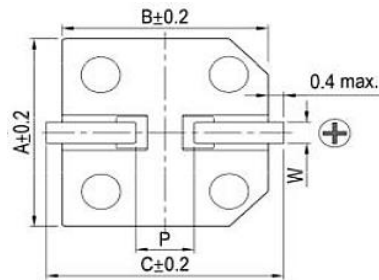
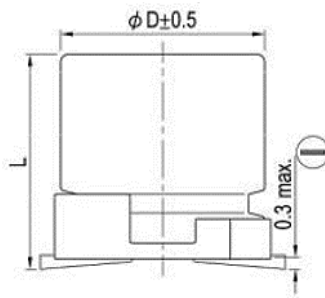

Symbol	Dimension (mm)
A	8.3
B	8.3
D	ϕ 8.0
C	9.0
L	10.2 +/- 0.5
p	3.1 +/-0.20
W	0.70~1.1



Marking

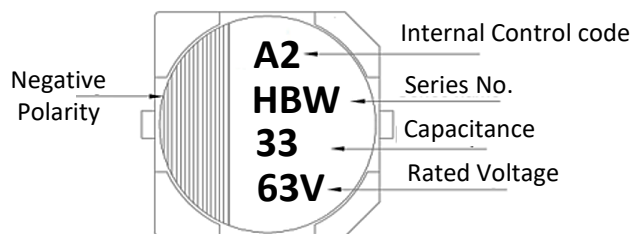

Recommended Pad Layout

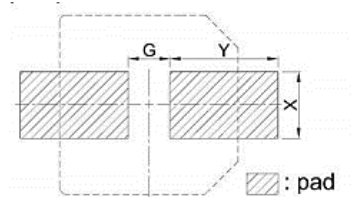

Symbol	Dimension
G	3.0
X	2.5
Y	3.5

CONDUCTIVE POLYMER HYBRID ALUMINUM ELEC. CAPACITORS HBW SERIES

CONSTRUCTION



No.	Parts	Material
1	Terminal	High pure aluminum, lead is tin copper clad steel wire
2	Isolator	Thermo-plastic resin
3	Aluminum Can	High purity aluminum, coated aluminum can
4	Sealing Rubber	Rubber
5	Separator	Manila hemp
6	Anode Foil	High pure aluminum formation foil
7	Cathode Foil	High pure aluminum carbon foil

CONDUCTIVE POLYMER HYBRID ALUMINUM ELEC. CAPACITORS HBW SERIES
CHARACTERISTICS
Standard Atmospheric Conditions

The standard range of atmospheric conditions for making measurements/test as follows:

Ambient temperature: 15°C to 35°C

Relative humidity: 45% to 75% ;

Air Pressure: 86kPa to 106kPa

If there is any doubt about the results, measurement shall be made within the following conditions:

Ambient temperature: 20°C ± 2°C

Relative humidity: 60% to 70%

Air Pressure: 86kPa to 106kPa

As to the detailed information, please refer to following Table

Operating Temperature Range

The ambient temperature range at which the capacitor can be operated continuously at rated voltage (16~80V) is -55°C to 125°C.

As to the detailed information, please refer to table 1

SPECIFICATION

No.	Characteristics	Spec	Unit	Description				
1	Capacitance	33	μF	Product nominal capacity, test frequency: 120Hz,20°C within the specified capacity tolerance				
2	Capacitance Tolerance	±20	%					
3	Working voltage	63	V	Rated working voltage				
4	Dissipation Factor	8	%	Also calls dissipation, test frequency: 120Hz				
5	Max ESR	40	mΩ	Equivalent series resistance, test frequency 100kHz				
6	Max rated ripple	1100	mA rms	The maximum allowable ripple current is 100kHz 125°C, the largest A.C current The DC voltage plus the peak AC voltage must not exceed the rated voltage,and non-reverse charging				
				Frequency	120Hz≤f<1kHz	1kHz≤f<10kHz	10kHz≤f<100kHz	100kHz≤f<500kHz
				Coefficient	0.10	0.30	0.60	1.00
7	Leakage Current	20.8	μA	Leakage current, after charging for 2 minutes, test the leakage current value of product (20°C)				
8	Temperature range	-55~125	°C	/				
9	Temperature Characteristics, Impedance Ratio	At -25°C 100kHz (Low temperature)		Z _{-25°C} /Z _{20°C} ≤1.5				
		At -55°C 100kHz (High temperature)		Z _{-55°C} /Z _{20°C} ≤2.0				

CONDUCTIVE POLYMER HYBRID ALUMINUM ELEC. CAPACITORS HBW SERIES

Table 2

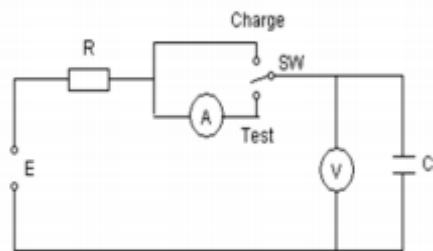
Item		PERFORMANCE														
4.1	Nominal capacitance (Tolerance)	<p><Condition> Measuring Frequency : 120Hz±12Hz Measuring Voltage : Not more than 0.5V Measuring Temperature : 20±2°C</p> <p><Criteria> Shall be within the specified capacitance tolerance.</p>														
4.2	Leakage Current	<p><Condition> After 2 minutes applications of rated working voltage at 20°C the rated working voltage shall be applied across the capacitor and its protective resistor which shall be 1000±100Ω.</p>  <p><Criteria> Remark:Refer to item 5</p>														
4.3	Tan δ	<p><Condition> See 4.1 Nominal capacitance, for measuring frequency, voltage and temperature.</p> <p><Criteria></p> <table border="1" data-bbox="411 1326 1082 1425"> <tr> <td>Working voltage (V)</td> <td>16</td> <td>25</td> <td>35</td> <td>50</td> <td>63</td> <td>80</td> </tr> <tr> <td>tan δ(max.)</td> <td>0.16</td> <td>0.14</td> <td>0.12</td> <td>0.10</td> <td>0.08</td> <td>0.08</td> </tr> </table>	Working voltage (V)	16	25	35	50	63	80	tan δ(max.)	0.16	0.14	0.12	0.10	0.08	0.08
Working voltage (V)	16	25	35	50	63	80										
tan δ(max.)	0.16	0.14	0.12	0.10	0.08	0.08										
4.4	ESR Ripple Current	<p>ESR :Equivalent series resistance, test frequency 100kHz</p> <p>Ripple Current : The maximum allowable ripple current is 100kHz, the largest A.C current The DC voltage plus the peak AC voltage must not exceed the rated voltage,and non-reverse charging</p>														

CONDUCTIVE POLYMER HYBRID ALUMINUM ELEC. CAPACITORS HBW SERIES

4.5	Characteristics at High and Low Temperature	<p><Condition></p> <table border="1" data-bbox="499 331 999 569"> <thead> <tr> <th>Step</th> <th>Testing Temperature(°C)</th> <th>Time(Min)</th> </tr> </thead> <tbody> <tr> <td>1</td> <td>20±2</td> <td>--</td> </tr> <tr> <td>2</td> <td>-25(-55)±3</td> <td>30</td> </tr> <tr> <td>3</td> <td>20±2</td> <td>10~15</td> </tr> <tr> <td>4</td> <td>125±2</td> <td>30</td> </tr> <tr> <td>5</td> <td>20±2</td> <td>10~15</td> </tr> </tbody> </table> <p><Criteria></p> <p>(1) Step.2 Impedance Ratio (at 100kHz)</p> <table border="1" data-bbox="425 683 1228 783"> <thead> <tr> <th>WV(VDC)</th> <th>16</th> <th>25</th> <th>35</th> <th>50</th> <th>63</th> <th>80</th> </tr> </thead> <tbody> <tr> <td>Z(-25°C)/Z(20°C)</td> <td>1.5</td> <td>1.5</td> <td>1.5</td> <td>1.5</td> <td>1.5</td> <td>1.5</td> </tr> <tr> <td>Z(-55°C)/Z(20°C)</td> <td>2.0</td> <td>2.0</td> <td>2.0</td> <td>2.0</td> <td>2.0</td> <td>2.0</td> </tr> </tbody> </table> <p>(2) Step 4.</p> <table border="1" data-bbox="488 866 1285 1031"> <tbody> <tr> <td>Leakage current</td> <td>Not more than 800% of the specified value</td> </tr> <tr> <td>Capacitance Change</td> <td>Within ±10% of Step1 value.</td> </tr> <tr> <td>tan δ</td> <td>Not more than the specified value.</td> </tr> <tr> <td>Appearance</td> <td>There shall be no leakage of electrolyte.</td> </tr> </tbody> </table>	Step	Testing Temperature(°C)	Time(Min)	1	20±2	--	2	-25(-55)±3	30	3	20±2	10~15	4	125±2	30	5	20±2	10~15	WV(VDC)	16	25	35	50	63	80	Z(-25°C)/Z(20°C)	1.5	1.5	1.5	1.5	1.5	1.5	Z(-55°C)/Z(20°C)	2.0	2.0	2.0	2.0	2.0	2.0	Leakage current	Not more than 800% of the specified value	Capacitance Change	Within ±10% of Step1 value.	tan δ	Not more than the specified value.	Appearance	There shall be no leakage of electrolyte.
Step	Testing Temperature(°C)	Time(Min)																																															
1	20±2	--																																															
2	-25(-55)±3	30																																															
3	20±2	10~15																																															
4	125±2	30																																															
5	20±2	10~15																																															
WV(VDC)	16	25	35	50	63	80																																											
Z(-25°C)/Z(20°C)	1.5	1.5	1.5	1.5	1.5	1.5																																											
Z(-55°C)/Z(20°C)	2.0	2.0	2.0	2.0	2.0	2.0																																											
Leakage current	Not more than 800% of the specified value																																																
Capacitance Change	Within ±10% of Step1 value.																																																
tan δ	Not more than the specified value.																																																
Appearance	There shall be no leakage of electrolyte.																																																
4.6	Terminal Strength	<p><Condition></p> <p>Capacitor is placed in the PCB by solder paste and do high temperature test (Reflow)2 twice to endurance the power of 1.8kg for 60S,no dropping condition.</p> <p><Criteria></p> <table border="1" data-bbox="488 1197 1285 1363"> <tbody> <tr> <td>Leakage current</td> <td>Not more than the specified value.</td> </tr> <tr> <td>Capacitance Change</td> <td>Within ±10% of initial value.</td> </tr> <tr> <td>tan δ</td> <td>Not more than the specified value.</td> </tr> <tr> <td>Appearance</td> <td>There shall be no leakage of electrolyte.</td> </tr> </tbody> </table>	Leakage current	Not more than the specified value.	Capacitance Change	Within ±10% of initial value.	tan δ	Not more than the specified value.	Appearance	There shall be no leakage of electrolyte.																																							
Leakage current	Not more than the specified value.																																																
Capacitance Change	Within ±10% of initial value.																																																
tan δ	Not more than the specified value.																																																
Appearance	There shall be no leakage of electrolyte.																																																
4.7	Mechanical Shock	<p><Condition></p> <p>Capacitor is placed in the PCB and fixed .Setting the acceleration (100g)and time(6ms) according to the test condition ,shock 6 times from three directions (X-Y-Z).</p> <p><Criteria></p> <table border="1" data-bbox="488 1554 1285 1761"> <tbody> <tr> <td>Leakage current</td> <td>Not more than the specified value.</td> </tr> <tr> <td>Capacitance Change</td> <td>Within ±10% of initial value.</td> </tr> <tr> <td>tan δ</td> <td>Not more than the specified value.</td> </tr> <tr> <td>ESR</td> <td>Not more than the specified value.</td> </tr> <tr> <td>Appearance</td> <td>There shall be no leakage of electrolyte.</td> </tr> </tbody> </table>	Leakage current	Not more than the specified value.	Capacitance Change	Within ±10% of initial value.	tan δ	Not more than the specified value.	ESR	Not more than the specified value.	Appearance	There shall be no leakage of electrolyte.																																					
Leakage current	Not more than the specified value.																																																
Capacitance Change	Within ±10% of initial value.																																																
tan δ	Not more than the specified value.																																																
ESR	Not more than the specified value.																																																
Appearance	There shall be no leakage of electrolyte.																																																

CONDUCTIVE POLYMER HYBRID ALUMINUM ELEC. CAPACITORS HBW SERIES

4.8	Load Life test	<p><Condition></p> <ol style="list-style-type: none"> Capacitors shall be placed in oven with application of rated ripple current for 4000 +72/-0hrs at 125°C. Then the capacitor shall be subjected to standard atmospheric conditions for 4 hours, after which measurements shall be made. <p><Criteria> The characteristic shall meet the following requirements.</p> <table border="1" data-bbox="468 582 1292 789"> <tr> <td>Leakage current</td> <td>Not more than the specified value.</td> </tr> <tr> <td>Capacitance Change</td> <td>Within ±30% of initial value.</td> </tr> <tr> <td>tan δ</td> <td>Not more than 200% of the specified value.</td> </tr> <tr> <td>ESR</td> <td>within ±200% of the initial value</td> </tr> <tr> <td>Appearance</td> <td>There shall be no leakage of electrolyte.</td> </tr> </table>	Leakage current	Not more than the specified value.	Capacitance Change	Within ±30% of initial value.	tan δ	Not more than 200% of the specified value.	ESR	within ±200% of the initial value	Appearance	There shall be no leakage of electrolyte.
Leakage current	Not more than the specified value.											
Capacitance Change	Within ±30% of initial value.											
tan δ	Not more than 200% of the specified value.											
ESR	within ±200% of the initial value											
Appearance	There shall be no leakage of electrolyte.											
4.9	Shelf Life test	<p><Condition> After 1000 +48/ -0 hours test at 125°C without rated working voltage. And then the capacitor shall be subjected to standard atmospheric conditions for 4 hours, after which measurements shall be made.</p> <p><Criteria> The characteristic shall meet the following requirements.</p> <table border="1" data-bbox="429 1085 1280 1301"> <tr> <td>Leakage current</td> <td>Not more than the specified value.</td> </tr> <tr> <td>Capacitance Change</td> <td>Within ±30% of initial value.</td> </tr> <tr> <td>tan δ</td> <td>Not more than 200%of the specified value.</td> </tr> <tr> <td>ESR</td> <td>within ±200%of the initial value</td> </tr> <tr> <td>Appearance</td> <td>There shall be no leakage of electrolyte.</td> </tr> </table>	Leakage current	Not more than the specified value.	Capacitance Change	Within ±30% of initial value.	tan δ	Not more than 200%of the specified value.	ESR	within ±200%of the initial value	Appearance	There shall be no leakage of electrolyte.
Leakage current	Not more than the specified value.											
Capacitance Change	Within ±30% of initial value.											
tan δ	Not more than 200%of the specified value.											
ESR	within ±200%of the initial value											
Appearance	There shall be no leakage of electrolyte.											
4.10	Resistance To Solvents	<p><Condition> Step 1:Put the capacitor into IPA(25±5°C); Step 2:the dipping time is 3+0.5/-0 minutes; Step 3:Brush the capacitor for 10 times; Conduct the steps 1~3 for 3 cycles.</p> <p><Criteria> The print cannot fall off or be obscure</p>										

CONDUCTIVE POLYMER HYBRID ALUMINUM ELEC. CAPACITORS HBW SERIES

4.11	Surge Voltage test	<p><Condition> The capacitor shall be subjected to 1000 cycles at 15 ~35°C. Protective series resistor a 1KΩ each consisting of a charge period of 30±5 seconds, followed by discharge period of approximately 5.5 minutes.</p> <p><Criteria></p> <table border="1" data-bbox="475 468 1265 623"> <tr> <td>Leakage current</td> <td>Not more than the specified value.</td> </tr> <tr> <td>Capacitance Change</td> <td>Within ±20% of initial value.</td> </tr> <tr> <td>tan δ</td> <td>Not more than the specified value.</td> </tr> <tr> <td>ESR</td> <td>within ±200%of the initial value</td> </tr> </table> <p>Surge voltage:</p> <table border="1" data-bbox="462 679 1152 768"> <tr> <td>WV (V.DC)</td> <td>16</td> <td>25</td> <td>35</td> <td>50</td> <td>63</td> <td>80</td> </tr> <tr> <td>SV (V.DC)</td> <td>18.4</td> <td>28.8</td> <td>40.3</td> <td>57.5</td> <td>72.5</td> <td>92</td> </tr> </table>	Leakage current	Not more than the specified value.	Capacitance Change	Within ±20% of initial value.	tan δ	Not more than the specified value.	ESR	within ±200%of the initial value	WV (V.DC)	16	25	35	50	63	80	SV (V.DC)	18.4	28.8	40.3	57.5	72.5	92
Leakage current	Not more than the specified value.																							
Capacitance Change	Within ±20% of initial value.																							
tan δ	Not more than the specified value.																							
ESR	within ±200%of the initial value																							
WV (V.DC)	16	25	35	50	63	80																		
SV (V.DC)	18.4	28.8	40.3	57.5	72.5	92																		
4.12	Vibration test	<p><Condition> Capacitor is placed in the PCB and fixed by glue .Setting the acceleration (5g) and frequency (10- 2000Hz) according to the test condition ,vibration 4Hrs from three directions (X-Y-Z).</p> <p><Criteria></p> <table border="1" data-bbox="475 986 1322 1282"> <tr> <td>Capacitance Change</td> <td>Within ±10% of initial value.</td> </tr> <tr> <td>Leakage current</td> <td>Not more than the specified value.</td> </tr> <tr> <td>tan δ</td> <td>Not more than the specified value.</td> </tr> <tr> <td>ESR</td> <td>Not more than the specified value.</td> </tr> <tr> <td>Inner construction</td> <td>No intermittent contacts, open or short circuiting. No damage of tab terminals or electrodes.</td> </tr> <tr> <td>Appearance</td> <td>No mechanical damage in terminal. No leakage of electrolyte or swelling of the case. The markings shall be legible.</td> </tr> </table>	Capacitance Change	Within ±10% of initial value.	Leakage current	Not more than the specified value.	tan δ	Not more than the specified value.	ESR	Not more than the specified value.	Inner construction	No intermittent contacts, open or short circuiting. No damage of tab terminals or electrodes.	Appearance	No mechanical damage in terminal. No leakage of electrolyte or swelling of the case. The markings shall be legible.										
Capacitance Change	Within ±10% of initial value.																							
Leakage current	Not more than the specified value.																							
tan δ	Not more than the specified value.																							
ESR	Not more than the specified value.																							
Inner construction	No intermittent contacts, open or short circuiting. No damage of tab terminals or electrodes.																							
Appearance	No mechanical damage in terminal. No leakage of electrolyte or swelling of the case. The markings shall be legible.																							
4.13	Un-biased Humidity	<p><Condition> Capacitors shall be exposed for 2000 +48/-0 hrs in an atmosphere of 85%±5% R.H. at 85±3°C. And then the capacitor shall be subjected to standard atmospheric conditions for 4 hours, after which measurements shall be made.</p> <p><Criteria></p> <table border="1" data-bbox="434 1508 1305 1728"> <tr> <td>Leakage current</td> <td>Not more than the specified value.</td> </tr> <tr> <td>Capacitance Change</td> <td>Within ±30% of initial value.</td> </tr> <tr> <td>tan δ</td> <td>Not more than 200% of the specified value.</td> </tr> <tr> <td>ESR</td> <td>Not more than 200% of the specified value.</td> </tr> <tr> <td>Appearance</td> <td>There shall be no leakage of electrolyte.</td> </tr> </table>	Leakage current	Not more than the specified value.	Capacitance Change	Within ±30% of initial value.	tan δ	Not more than 200% of the specified value.	ESR	Not more than 200% of the specified value.	Appearance	There shall be no leakage of electrolyte.												
Leakage current	Not more than the specified value.																							
Capacitance Change	Within ±30% of initial value.																							
tan δ	Not more than 200% of the specified value.																							
ESR	Not more than 200% of the specified value.																							
Appearance	There shall be no leakage of electrolyte.																							

CONDUCTIVE POLYMER HYBRID ALUMINUM ELEC. CAPACITORS HBW SERIES

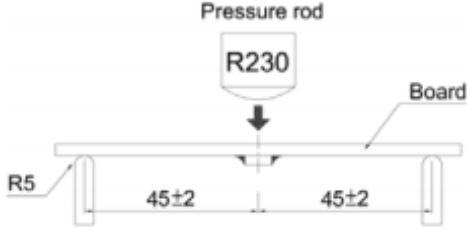
<p>4.14</p>	<p>Board Flex Test</p>	<p><Condition> Capacitor is placed in the PCB and pressed to deviate from Original fulcrum less than 2mm for 60 (+5) s.</p>  <p><Criteria></p> <table border="1"> <tr> <td>Leakage current</td> <td>Not more than the specified value.</td> </tr> <tr> <td>Capacitance Change</td> <td>Within ±10% of initial value.</td> </tr> <tr> <td>tan δ</td> <td>Not more than the specified value.</td> </tr> <tr> <td>ESR</td> <td>Not more than the specified value.</td> </tr> <tr> <td>Appearance</td> <td>There shall be no leakage of electrolyte.</td> </tr> </table>	Leakage current	Not more than the specified value.	Capacitance Change	Within ±10% of initial value.	tan δ	Not more than the specified value.	ESR	Not more than the specified value.	Appearance	There shall be no leakage of electrolyte.
Leakage current	Not more than the specified value.											
Capacitance Change	Within ±10% of initial value.											
tan δ	Not more than the specified value.											
ESR	Not more than the specified value.											
Appearance	There shall be no leakage of electrolyte.											
<p>4.15</p>	<p>Biased Humidity test</p>	<p><Condition> Capacitors shall be rated working voltage for 2000 +48/-0 hrs in an atmosphere of 85%±5% R.H. at 85±3°C. And then the capacitor shall be subjected to standard atmospheric conditions for 4 hours, after which measurements shall be made.</p> <p><Criteria></p> <table border="1"> <tr> <td>Leakage current</td> <td>Not more than the specified value.</td> </tr> <tr> <td>Capacitance Change</td> <td>Within ±30% of initial value.</td> </tr> <tr> <td>tan δ</td> <td>Not more than 200% of the specified value.</td> </tr> <tr> <td>ESR</td> <td>Not more than 200% of the specified value.</td> </tr> <tr> <td>Appearance</td> <td>There shall be no leakage of electrolyte.</td> </tr> </table>	Leakage current	Not more than the specified value.	Capacitance Change	Within ±30% of initial value.	tan δ	Not more than 200% of the specified value.	ESR	Not more than 200% of the specified value.	Appearance	There shall be no leakage of electrolyte.
Leakage current	Not more than the specified value.											
Capacitance Change	Within ±30% of initial value.											
tan δ	Not more than 200% of the specified value.											
ESR	Not more than 200% of the specified value.											
Appearance	There shall be no leakage of electrolyte.											
<p>4.16</p>	<p>Electrical Characterization</p>	<p><Condition> Whether there is abnormality about electrical characterization in the test that under the ensurance temperature(the lowest ,the highest, atmospheric temperature).</p> <p><Criteria> Appearance: No abnormality</p>										

CONDUCTIVE POLYMER HYBRID ALUMINUM ELEC. CAPACITORS HBW SERIES

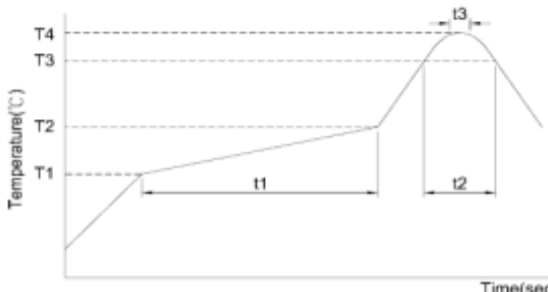
4.17	Rotational Temperature test	<p><Condition> Step1: Max. rated temperature$\pm 3^{\circ}\text{C}$(30mins) Step2: Min. rated temperature$\pm 3^{\circ}\text{C}$(30mins) Max.transfer time: 1min According to the step1 to step2, and do 1000cycles</p> <p><Criteria></p> <table border="1"> <tr> <td>Leakage current</td> <td>Not more than the specified value.</td> </tr> <tr> <td>Capacitance Change</td> <td>Within $\pm 20\%$ of initial value.</td> </tr> <tr> <td>tan δ</td> <td>Not more than 200% of the specified value.</td> </tr> <tr> <td>ESR</td> <td>Not more than 200% of the specified value.</td> </tr> <tr> <td>Appearance</td> <td>There shall be no leakage of electrolyte.</td> </tr> </table>	Leakage current	Not more than the specified value.	Capacitance Change	Within $\pm 20\%$ of initial value.	tan δ	Not more than 200% of the specified value.	ESR	Not more than 200% of the specified value.	Appearance	There shall be no leakage of electrolyte.																																
Leakage current	Not more than the specified value.																																											
Capacitance Change	Within $\pm 20\%$ of initial value.																																											
tan δ	Not more than 200% of the specified value.																																											
ESR	Not more than 200% of the specified value.																																											
Appearance	There shall be no leakage of electrolyte.																																											
4.18	Resistance to Soldering Heat test	<p><Condition> IR Reflow:</p>  <table border="1"> <tr> <td rowspan="2">Preheat</td> <td>Temperature($T_1 \sim T_2^{\circ}\text{C}$)</td> <td colspan="3">150~180</td> </tr> <tr> <td>Time(t_1) Max. s</td> <td colspan="3">120</td> </tr> <tr> <td rowspan="2">Duration</td> <td>Temperature($T_3^{\circ}\text{C}$)</td> <td>200</td> <td>217</td> <td>230</td> </tr> <tr> <td>Time(t_2) Max. s</td> <td>70</td> <td>50</td> <td>40</td> </tr> <tr> <td rowspan="2">Highest temperatures</td> <td>Temperature($T_4^{\circ}\text{C}$)</td> <td>250</td> <td colspan="2">260</td> </tr> <tr> <td>Time(t_3) Max. s</td> <td colspan="3">5</td> </tr> <tr> <td colspan="2">The number of reflow</td> <td>2</td> <td colspan="2">1</td> </tr> </table> <ul style="list-style-type: none"> * Please contact our representative if your condition is higher. * Please ensure that the capacitor became cold enough to the room temperature ($5^{\circ}\text{C} \sim 35^{\circ}\text{C}$) before the second reflow. * Consult with us when performing reflow profile in IPC / JEDEC (J-STD-020) <p><Criteria> The characteristic shall meet the following requirement.</p> <table border="1"> <tr> <td>Leakage current</td> <td>Not more than the specified value.</td> </tr> <tr> <td>Capacitance Change</td> <td>Within $\pm 10\%$ of initial value.</td> </tr> <tr> <td>tan δ</td> <td>Not more than the specified value.</td> </tr> <tr> <td>ESR</td> <td>Not more than the specified value.</td> </tr> <tr> <td>Appearance</td> <td>There shall be no leakage of electrolyte.</td> </tr> </table>	Preheat	Temperature($T_1 \sim T_2^{\circ}\text{C}$)	150~180			Time(t_1) Max. s	120			Duration	Temperature($T_3^{\circ}\text{C}$)	200	217	230	Time(t_2) Max. s	70	50	40	Highest temperatures	Temperature($T_4^{\circ}\text{C}$)	250	260		Time(t_3) Max. s	5			The number of reflow		2	1		Leakage current	Not more than the specified value.	Capacitance Change	Within $\pm 10\%$ of initial value.	tan δ	Not more than the specified value.	ESR	Not more than the specified value.	Appearance	There shall be no leakage of electrolyte.
Preheat	Temperature($T_1 \sim T_2^{\circ}\text{C}$)	150~180																																										
	Time(t_1) Max. s	120																																										
Duration	Temperature($T_3^{\circ}\text{C}$)	200	217	230																																								
	Time(t_2) Max. s	70	50	40																																								
Highest temperatures	Temperature($T_4^{\circ}\text{C}$)	250	260																																									
	Time(t_3) Max. s	5																																										
The number of reflow		2	1																																									
Leakage current	Not more than the specified value.																																											
Capacitance Change	Within $\pm 10\%$ of initial value.																																											
tan δ	Not more than the specified value.																																											
ESR	Not more than the specified value.																																											
Appearance	There shall be no leakage of electrolyte.																																											

CONDUCTIVE POLYMER HYBRID ALUMINUM ELEC. CAPACITORS HBW SERIES

4.19	Venting Test	<p><Condition> 1.Applicable to the capacitors with case size is 10φ mm and larger. 2. Test condition: DC test: Applying inverse DC rated voltage with current to the capacitor. Where case diameter: φD ≦ 22.4mm: 1 A DC max φD > 22.4mm: 10 A DC max</p> <p><Criteria> (1) When the pressure relief vent operated, the capacitor shall avoid any danger of fire or explosion of capacitor element (terminal and metal foil etc.) or cover. (2) When the pressure relief device does not open with the voltage applied over 30 minutes, the test is considered to be passed.</p>		
4.20	Solderability Test	<p><Condition> Solderability test 1: Pre-conditioning: execution according to RDD0302 (Solderability Test Method), item 4.4.2- 1 (chart 3) Solder bath temperature: 235±5°C Duration: 5+0/-0.5s</p> <p>Solderability test 2: Pre-conditioning: execution according to RDD0302 (Solderability Test Methode) , item 4.4.2-1 (chart 3) Solder bath temperature: 215±3°C Duration: 5+0/-0.5s</p> <p>Solderability test 3: Pre-conditioning: execution according to RDD0302 (Solderability Test Methode) , item 4.4.2-1 (chart 3) Solder bath temperature: 260±5°C Duration: 7±0.5s</p> <p><Criteria></p> <table border="1" data-bbox="449 1353 1220 1384"> <tr> <td>Coating quality</td> <td>A minimum of 95% of the surface being immersed</td> </tr> </table>	Coating quality	A minimum of 95% of the surface being immersed
Coating quality	A minimum of 95% of the surface being immersed			
4.21	Coating Case	<p>The color of coating case will turn light khaki from colorless with long duration in high temperature. Should there is any concern with the color changing of coating case, please consult with us</p>		

CONDUCTIVE POLYMER HYBRID ALUMINUM ELEC. CAPACITORS HBW SERIES

CASE SIZE & MAX RIPPLE CURRENT

Rated Voltage V	Capacitance (+/-20%) μF	Case Size ØD*L mm	Dissipation Factor @+20°C, 120Hz Tanδ Max.	Ripple Current @+125°C, 100KHz mA rms .	ESR (mΩ,20°C, 100kHz)	Leakage Current (μA/2min) μA Max.
63	33	8.0*10.2	0.08	1100	40	20.8

Remark:

- 1) Specification are subject to change without notice should a safety or technical concern arise regarding the product please be sure to contact our sales offices;
- 2)The sizes in the above table are all general specifications. If you need other specifications, please contact us.
- 3) Frequency Coefficient of Allowable Ripple Current:

Frequency	120Hz≤f<1kHz	1kHz≤f<10kHz	10kHz≤f<100kHz	100kHz≤f<500kHz
Coefficient	0.10	0.30	0.70	1.00

CONDUCTIVE POLYMER HYBRID ALUMINUM ELEC. CAPACITORS HBW SERIES

TAPE (Unit: mm), 500pcs/Reel,

Applicable standard JIS C0806 and IEC 60286.

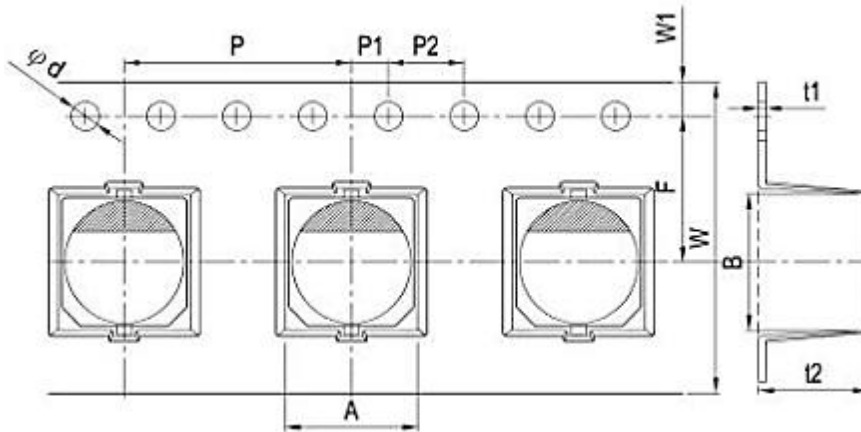

REEL (Unit: mm)

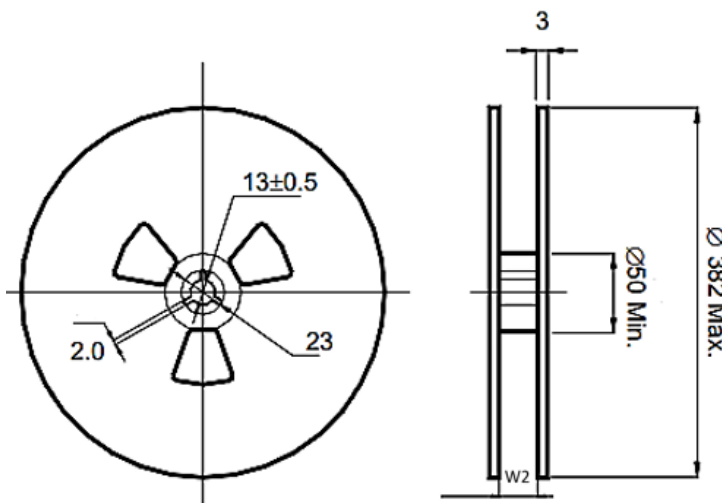

→ Pull out direction

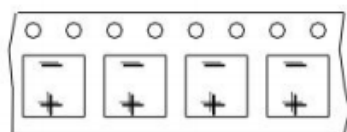

Case size: $\phi D8.0 * L10.2mm$	
Symbol	Dimension (mm)
W	24.0
P	16.0
F	11.5
A	8.7
B	8.7
T 2	11.0
ϕd	1.5
P 1	2.0
P 2	4.0
t 1	0.4
W 1	1.75
W 2	26.0 +/-0.3

CONDUCTIVE POLYMER HYBRID ALUMINUM ELEC. CAPACITORS HBW SERIES

PACKING METHOD

Polarity: Anode on the opposite side of the feed hole

The leader length of the tape shall not be less than 400mm including 10 or more embossed sections in which no parts are contained.

The winding core is provided with an over 40mm long empty section

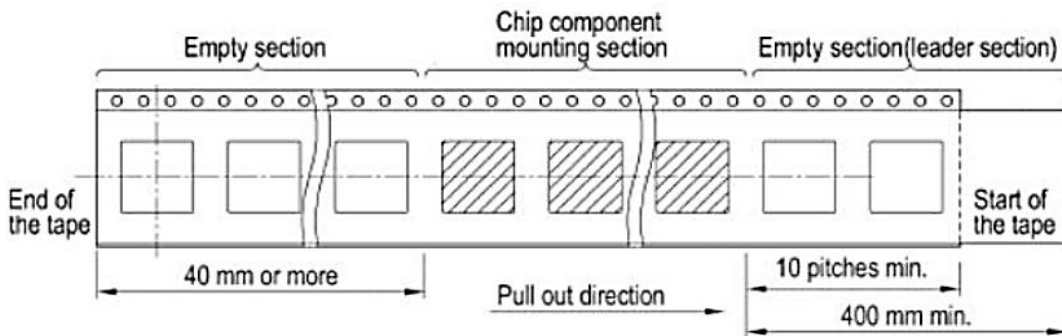

AEC-Q200 COMPLIANCE

Automotive Electronics Counsel (AEC) has established various electronic component qualification/reliability standards in order to serve automotive electronics industry. AEC-Q200 standard is dedicated for passive components like capacitors, inductors, etc. and is widely adopted domestically as well as internationally. NextGen/Aillen offers compliant product designs and support services to satisfy customers’ product requirements, including the AEC-Q200 required criteria of the reliability tests. NextGen/Aillen ’s capacitors are professionally designed to outperform all requirements of AEC-Q200.

DISCLAIMER

NextGen Component, Inc. reserves the right to make changes to the product(s) and or information contained herein without notice. No liability is assumed as a result of their use or application. No rights under any patent accompany the sale of any such product(s) or information