

This appliance can be used by children aged from 8 years and above and persons with reduced physical, sensory or mental capabilities or lack of experience and knowledge if they have been given supervision or instruction concerning use of the appliance in a safe way and understand the hazards involved. Children shall not play with the appliance. Cleaning and user maintenance shall not be made by children without supervision.

A fire may result if the appliance is not used with care, therefore:

- ◆ be careful when using the appliance in places where there are combustible materials ;
- ◆ do not apply to the same place for a long time;
- ◆ do not use in presence of an explosive atmosphere;
- ◆ be aware that heat may be conducted to combustible materials that are out of sight;
- ◆ place the appliance on its stand after use and allow it to cool down before storage;
- ◆ do not leave the appliance unattended when it is switched on.

<b>Correct Disposal of this product</b>	
	This marking indicates that this product should not be disposed with other household wastes throughout the EU. To prevent possible harm to the environment or human health from uncontrolled waste disposal, recycle it responsibly to promote the sustainable reuse of material resources. To return your used device, please use the return and collection systems or contact the retailer where the product was purchased. They can take this product for environmental safe recycling.

**AOYUE INTERNATIONAL LIMITED**

Jishui Industrial Zone, Nantou, Zhongshan City,  
Guangdong Province, P.R.China  
<http://www.aoyue3d.com>

This appliance can be used by children aged from 8 years and above and persons with reduced physical, sensory or mental capabilities or lack of experience and knowledge if they have been given supervision or instruction concerning use of the appliance in a safe way and understand the hazards involved. Children shall not play with the appliance. Cleaning and user maintenance shall not be made by children without supervision.

A fire may result if the appliance is not used with care, therefore:

- ◆ be careful when using the appliance in places where there are combustible materials ;
- ◆ do not apply to the same place for a long time;
- ◆ do not use in presence of an explosive atmosphere;
- ◆ be aware that heat may be conducted to combustible materials that are out of sight;
- ◆ place the appliance on its stand after use and allow it to cool down before storage;
- ◆ do not leave the appliance unattended when it is switched on.

<b>Correct Disposal of this product</b>	
	This marking indicates that this product should not be disposed with other household wastes throughout the EU. To prevent possible harm to the environment or human health from uncontrolled waste disposal, recycle it responsibly to promote the sustainable reuse of material resources. To return your used device, please use the return and collection systems or contact the retailer where the product was purchased. They can take this product for environmental safe recycling.

**AOYUE INTERNATIONAL LIMITED**

Jishui Industrial Zone, Nantou, Zhongshan City,  
Guangdong Province, P.R.China  
<http://www.aoyue3d.com>

**AOYUE3D®**

**Ritocco**

Touch up tool for 3d prints

**Instruction Manual**

Thank you for purchasing Ritocco touch up tool for 3d prints. Please read the manual before using the unit.

Keep manual in accessible place for future reference.

This manual is designed to familiarize and instruct the technician with the proper operation and maintenance of the equipment. Please read carefully and observe the guidelines in order to maximize usage and minimize the risk of injury or accidents .

**AOYUE3D®**

**Ritocco**

Touch up tool for 3d prints

**Instruction Manual**

Thank you for purchasing Ritocco touch up tool for 3d prints. Please read the manual before using the unit.

Keep manual in accessible place for future reference.

This manual is designed to familiarize and instruct the technician with the proper operation and maintenance of the equipment. Please read carefully and observe the guidelines in order to maximize usage and minimize the risk of injury or accidents .

# **TABLE OF CONTENTS**

Product Description .....	3
Package Inclusion .....	3
Safety Precautions .....	4
Specification .....	5
Functions and Features .....	5
Holder Assembly Instruction .....	6-8
Display Controls .....	9
Quick Tip Change .....	10
Operating Guidelines	
Easy mode .....	11-14
Advanced mode .....	15-16
Digital offset .....	17-18
Sleep .....	19-20
Temperature scale .....	21
Advanced options I .....	22-24
Advanced options II .....	25-26

# **TABLE OF CONTENTS**

Product Description .....	3
Package Inclusion .....	3
Safety Precautions .....	4
Specification .....	5
Functions and Features .....	5
Holder Assembly Instruction .....	6-8
Display Controls .....	9
Quick Tip Change .....	10
Operating Guidelines	
Easy mode .....	11-14
Advanced mode .....	15-16
Digital offset .....	17-18
Sleep .....	19-20
Temperature scale .....	21
Advanced options I .....	22-24
Advanced options II .....	25-26

## OPERATING GUIDELINES

### From Mode Lock Selection

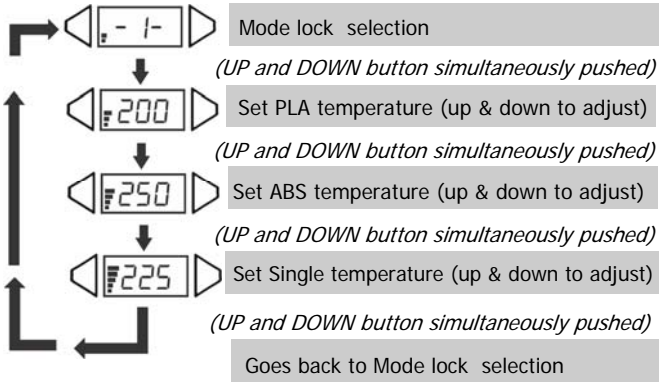

### Sample: Set tool to PLA only with temperature of 180

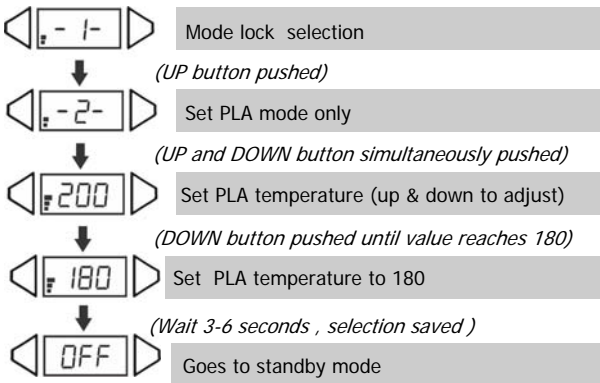

## PRODUCT DESCRIPTION

The Aoyue 3D Ritocco is the world's most advanced sculpting and retouching tool for 3D prints. Its revolutionary compound heater and tip design allows fast heat up and heat response to tackle any retouching jobs.

The hot swapping compound tip design allows changing of tips instantly within seconds. Its digital LCD read out and tactile button allows easy monitoring and adjustment of modes and temperature.

The slim and sleek design is easy to hold and is packed with advanced functions and features unrivaled in the industry.

## PACKAGE INCLUSION

- Ritocco pen
- 4 different sculpting and blending tip.
- Heat resistant Pad
- Pen stand

## OPERATING GUIDELINES

### From Mode Lock Selection

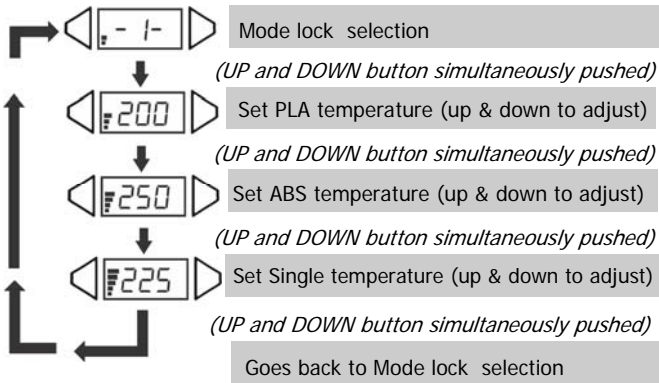

### Sample: Set tool to PLA only with temperature of 180

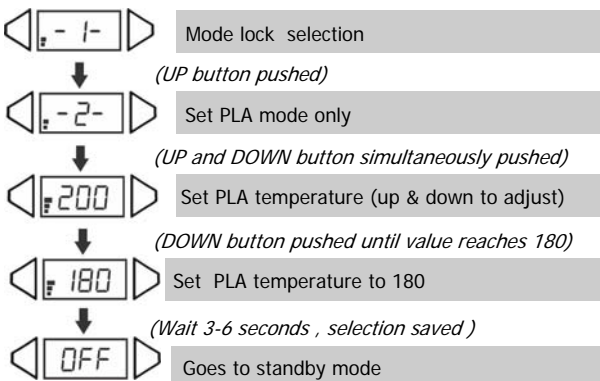

## PRODUCT DESCRIPTION

The Aoyue 3D Ritocco is the world's most advanced sculpting and retouching tool for 3D prints. Its revolutionary compound heater and tip design allows fast heat up and heat response to tackle any retouching jobs.

The hot swapping compound tip design allows changing of tips instantly within seconds. Its digital LCD read out and tactile button allows easy monitoring and adjustment of modes and temperature.

The slim and sleek design is easy to hold and is packed with advanced functions and features unrivaled in the industry.

## PACKAGE INCLUSION

- Ritocco pen
- 4 different sculpting and blending tip.
- Heat resistant Pad
- Pen stand

## SAFETY PRECAUTIONS



**CAUTION:** Improper usage can cause serious injury to personnel and/or damage to equipment and work area. For your own safety please observe the following precautions.

- Check each component after opening the package to make sure everything is in good condition. If there are any suspected damage, do not use the item and report the issue to your vendor.
- Do not strike or subject the unit to physical shock. Use carefully to avoid damage to any part.
  - Never drop or sharply jolt the unit.
  - Contains delicate parts that may break if the unit is dropped.
- Tip temperature may reach as high as 400°C when switched ON.
  - Do not use the device near flammable materials.
  - Do not touch heated parts, which can cause severe burns.
  - Do not touch metallic parts near the tip.
- Disconnect the plug from the power after use.
- Melting or retouching plastics produces smoke, use on well ventilated places.
- Do not alter the unit, specifically the internal circuitry, in any

The manufacturer declines all responsibility for any damage caused by incorrect or unreasonable use, such as:

- Improper use by untrained persons;
- Technical modifications or operations not recommended by the manufacturer;
- use of non-original or non-specific spare parts;
- failure to follow the instructions given in this manual.

## OPERATING GUIDELINES

### ADVANCED OPTIONS II

Within the advanced options selection we can also set the PLA Mode temperature , ABS Mode temperature, and the Single set temperature mode temperature.

PLA Mode temperature : default value is 200.

ABS Mode temperature : default value is 250.

Single Set temperature Mode : default value is 225.

#### From off to Mode Lock Selection

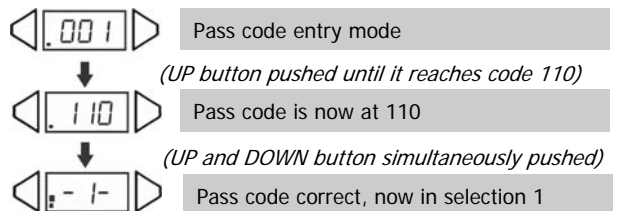
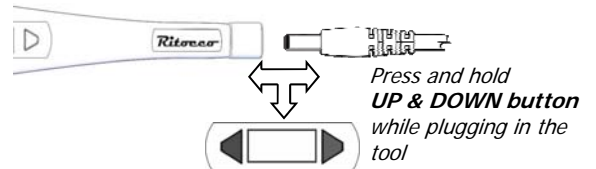

## SAFETY PRECAUTIONS



**CAUTION:** Improper usage can cause serious injury to personnel and/or damage to equipment and work area. For your own safety please observe the following precautions.

- Check each component after opening the package to make sure everything is in good condition. If there are any suspected damage, do not use the item and report the issue to your vendor.
- Do not strike or subject the unit to physical shock. Use carefully to avoid damage to any part.
  - Never drop or sharply jolt the unit.
  - Contains delicate parts that may break if the unit is dropped.
- Tip temperature may reach as high as 400°C when switched ON.
  - Do not use the device near flammable materials.
  - Do not touch heated parts, which can cause severe burns.
  - Do not touch metallic parts near the tip.
- Disconnect the plug from the power after use.
- Melting or retouching plastics produces smoke, use on well ventilated places.
- Do not alter the unit, specifically the internal circuitry, in any

The manufacturer declines all responsibility for any damage caused by incorrect or unreasonable use, such as:

- Improper use by untrained persons;
- Technical modifications or operations not recommended by the manufacturer;
- use of non-original or non-specific spare parts;
- failure to follow the instructions given in this manual.

## OPERATING GUIDELINES

### ADVANCED OPTIONS II

Within the advanced options selection we can also set the PLA Mode temperature , ABS Mode temperature, and the Single set temperature mode temperature.

PLA Mode temperature : default value is 200.

ABS Mode temperature : default value is 250.

Single Set temperature Mode : default value is 225.

#### From off to Mode Lock Selection

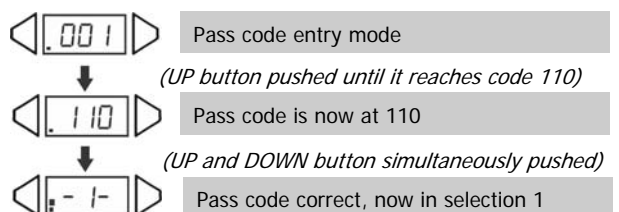
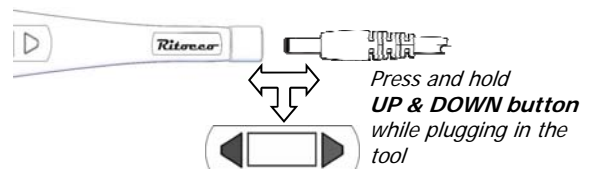

## OPERATING GUIDELINES

### From off to Mode Lock Selection

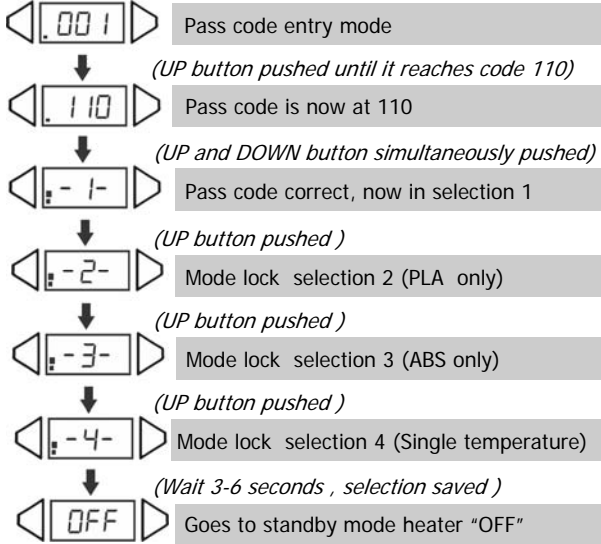
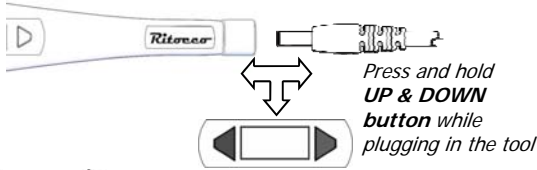

## SPECIFICATION

MAIN STATION	
Voltage Input :	12V DC
Weight:	50 grams
Temperature:	up to 150-400°C (302 to 752°F )
Heating Element:	Composite Ceramic heater

## FUNCTIONS and FEATURES

- Composite tip with quick change design.
- Composite ceramic heating element.
- Portable and lightweight.
- LCD display for easy monitoring.
- Easy and Advanced Mode.
- Lock Out Feature.
- Auto sleep function.
- Digital Offset.
- Switch between Centigrade and Fahrenheit Scale.

## OPERATING GUIDELINES

### From off to Mode Lock Selection

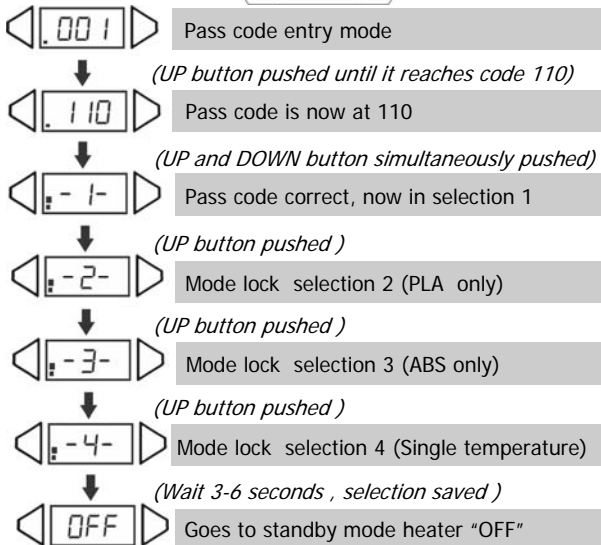
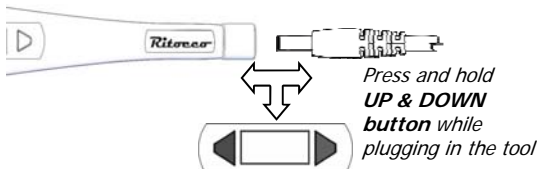

## SPECIFICATION

MAIN STATION	
Voltage Input :	12V DC
Weight:	50 grams
Temperature:	up to 150-400°C (302 to 752°F )
Heating Element:	Composite Ceramic heater

## FUNCTIONS and FEATURES

- Composite tip with quick change design.
- Composite ceramic heating element.
- Portable and lightweight.
- LCD display for easy monitoring.
- Easy and Advanced Mode.
- Lock Out Feature.
- Auto sleep function.
- Digital Offset.
- Switch between Centigrade and Fahrenheit Scale.

## HOLDER ASSEMBLY INSTRUCTION

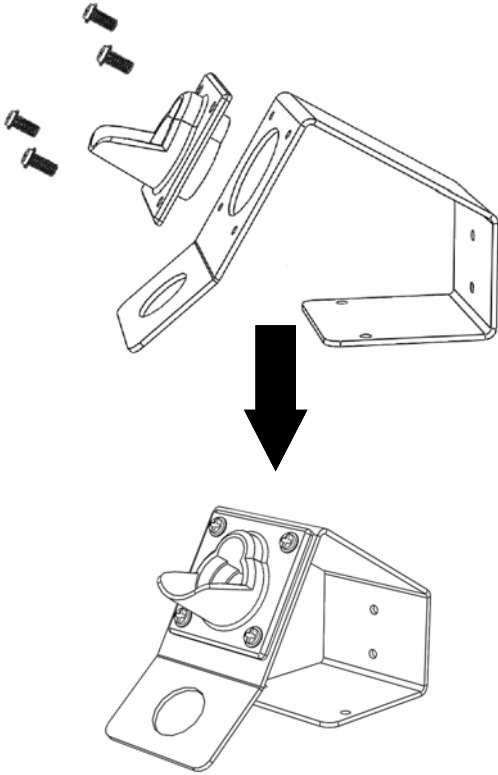

## HOLDER ASSEMBLY INSTRUCTION

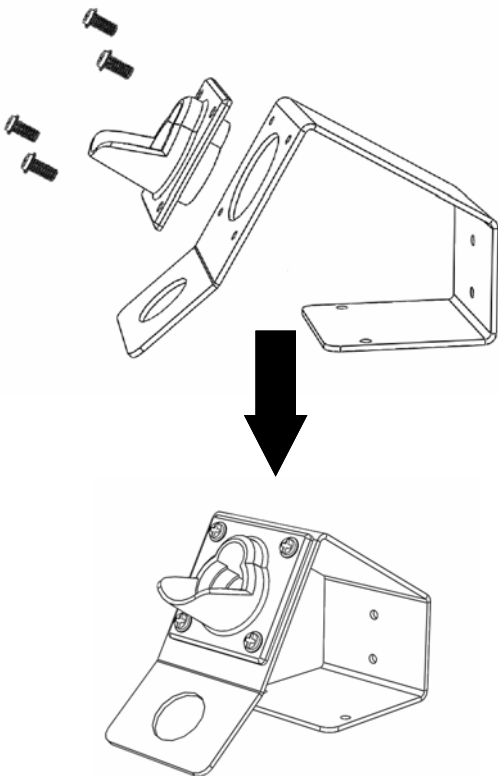

## OPERATING GUIDELINES

### To enter advanced options

Advanced option mode can be accessed via a pass code. The pass code is "110"

1. Press and hold both up and down button while plugging in the Ritocco the display would show "001" indicating the user to enter the pass code.
2. Press the up button to select pass code 110. Press both up and down button to enter the pass code. If correctly done the display would show "-1-" indicating it is now in the mode lock selection screen.

### To Select and lock between modes

Upon accessing the mode lock selection screen we can now select the modes.

1. Press the up or down button to select between modes 1 to 4. (see page 19 for mode functions)
2. After selection wait for 10 seconds for the system to save and register the selected mode.
3. Selected mode will be saved into memory.
4. To change system to other modes enter advanced options and selection modes again.

## OPERATING GUIDELINES

### To enter advanced options

Advanced option mode can be accessed via a pass code. The pass code is "110"

1. Press and hold both up and down button while plugging in the Ritocco the display would show "001" indicating the user to enter the pass code.
2. Press the up button to select pass code 110. Press both up and down button to enter the pass code. If correctly done the display would show "-1-" indicating it is now in the mode lock selection screen.

### To Select and lock between modes

Upon accessing the mode lock selection screen we can now select the modes.

1. Press the up or down button to select between modes 1 to 4. (see page 19 for mode functions)
2. After selection wait for 10 seconds for the system to save and register the selected mode.
3. Selected mode will be saved into memory.
4. To change system to other modes enter advanced options and selection modes again.

## OPERATING GUIDELINES

### ADVANCED OPTIONS I

The system can allow parents or teachers to lock out other modes so the tool can only be used in a specific mode or temperature. This is to restrict users from setting a temperature that is unsuitable for the materials being worked on.

#### Mode "1"

Default mode: user has access to all the functions and features of the device.

#### Mode "2"

PLA mode only: user can only use PLA mode. With level adjustments.

#### Mode "3"

ABS mode only: user can only access ABS mode. With level adjustments.

#### Mode "4"

Single temperature mode only: only a single set temperature is allowed no other temperature options available.

## HOLDER ASSEMBLY INSTRUCTION

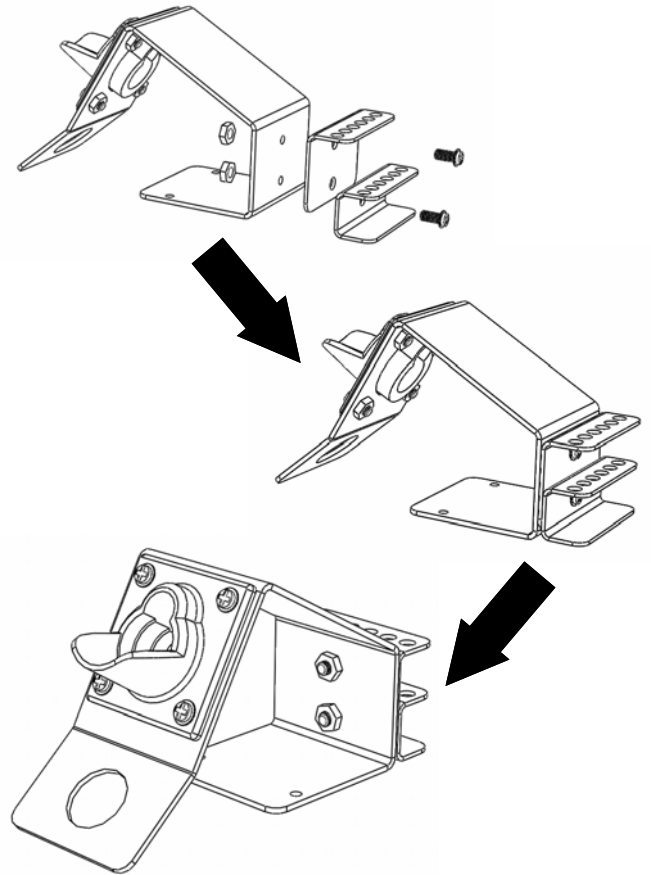

## OPERATING GUIDELINES

### ADVANCED OPTIONS I

The system can allow parents or teachers to lock out other modes so the tool can only be used in a specific mode or temperature. This is to restrict users from setting a temperature that is unsuitable for the materials being worked on.

#### Mode "1"

Default mode: user has access to all the functions and features of the device.

#### Mode "2"

PLA mode only: user can only use PLA mode. With level adjustments.

#### Mode "3"

ABS mode only: user can only access ABS mode. With level adjustments.

#### Mode "4"

Single temperature mode only: only a single set temperature is allowed no other temperature options available.

## HOLDER ASSEMBLY INSTRUCTION

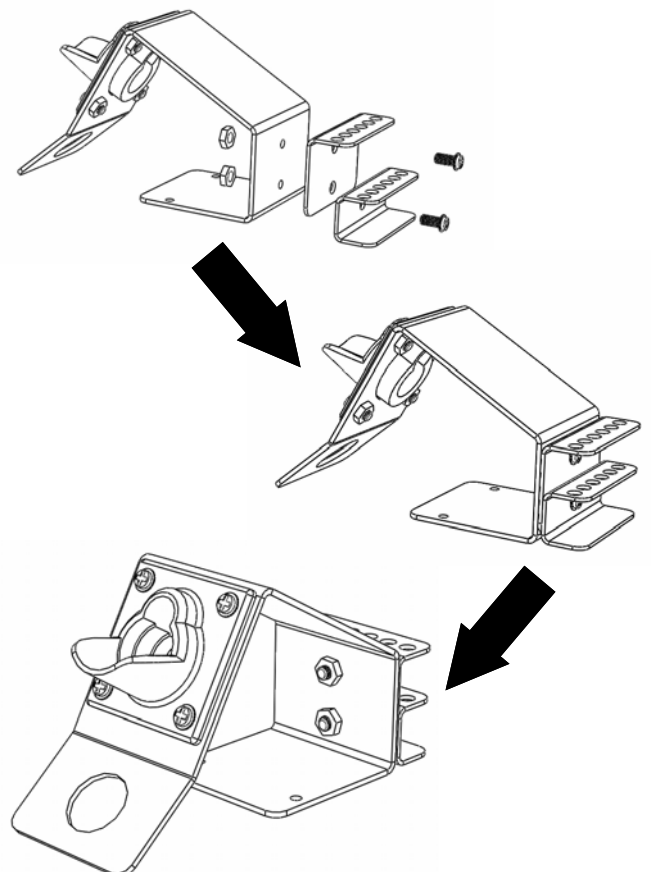

## HOLDER ASSEMBLY INSTRUCTION

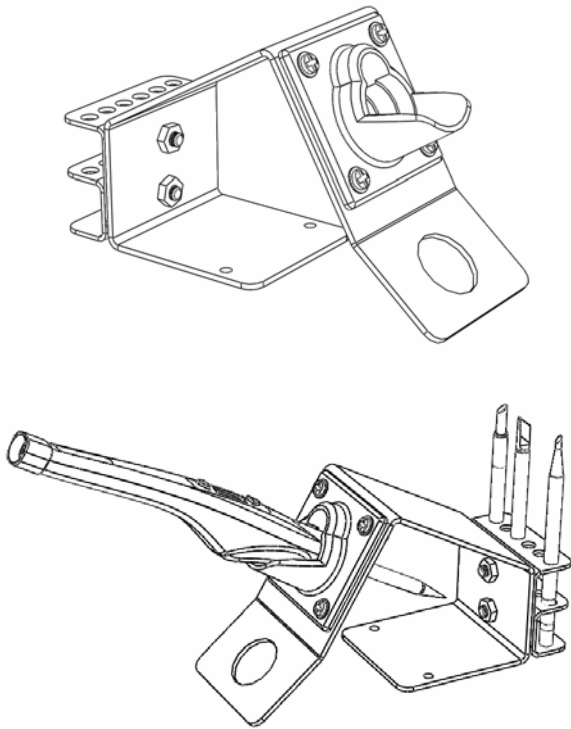

8

## HOLDER ASSEMBLY INSTRUCTION

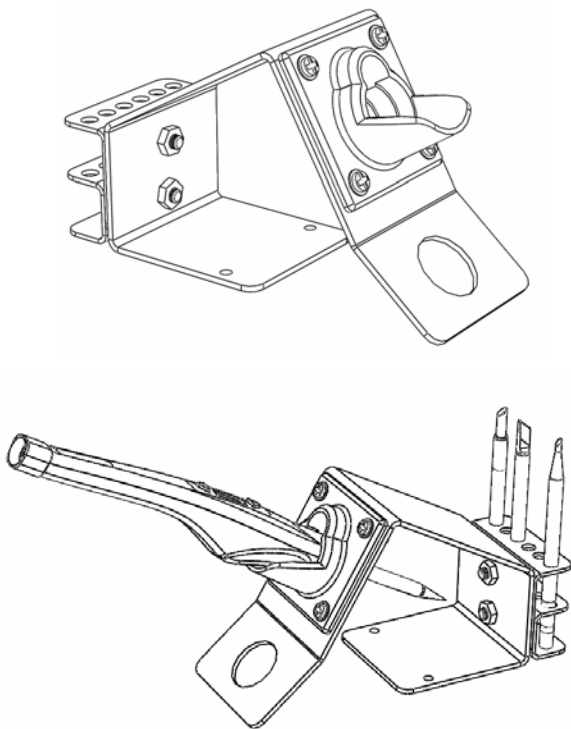

8

## OPERATING GUIDELINES

### TEMPERATURE SCALE

The system's temperature scale can be switched between Centigrade or Fahrenheit. To switch the display scale press the up button while plugging in the Ritocco the display would show the Celsius sign, press the up or down button to switch between Celsius or Fahrenheit scale. Wait for 3—5 seconds, the display will save the new settings and revert to standby mode.

#### From off to temperature scale selection

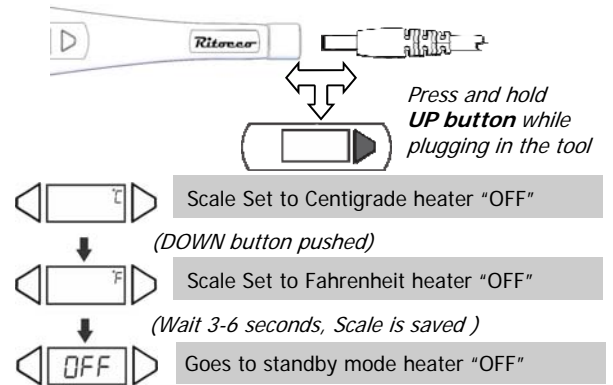

21

## OPERATING GUIDELINES

### TEMPERATURE SCALE

The system's temperature scale can be switched between Centigrade or Fahrenheit. To switch the display scale press the up button while plugging in the Ritocco the display would show the Celsius sign, press the up or down button to switch between Celsius or Fahrenheit scale. Wait for 3—5 seconds, the display will save the new settings and revert to standby mode.

#### From off to temperature scale selection

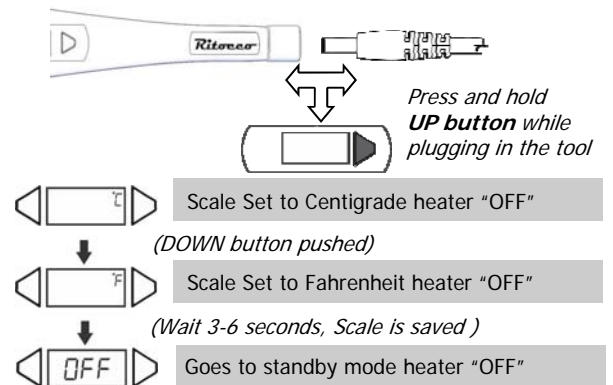

21



## OPERATING GUIDELINES

### From off to Sleep timer adjustment

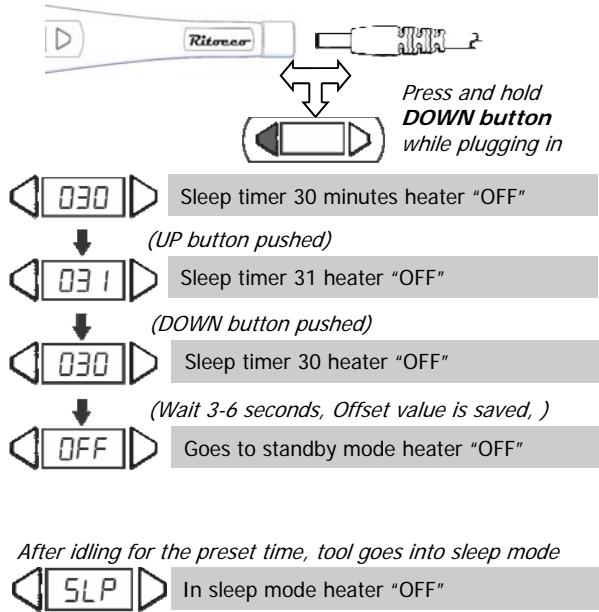

## DISPLAY AND CONTROL

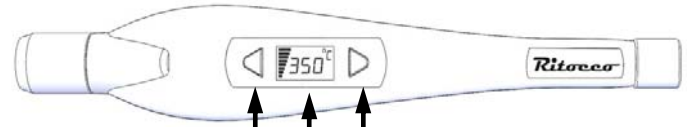

- 1 — Down Button
- 2 — LCD Display
- 3 — Up Button

- 4 — Heating power
- 5 — Mode Display
- 6 — Temperature Scale

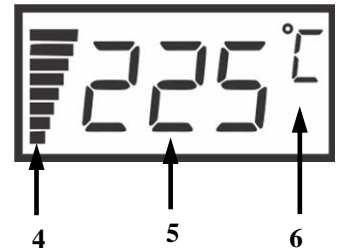

**Warning:** Never leave retouching tool unattended while in operation. Tip temperature may reach as high as 400 degrees. Only place retouching tool on non-flammable surface. Keep away from flammable and combustible objects and surfaces.

## OPERATING GUIDELINES

### From off to Sleep timer adjustment

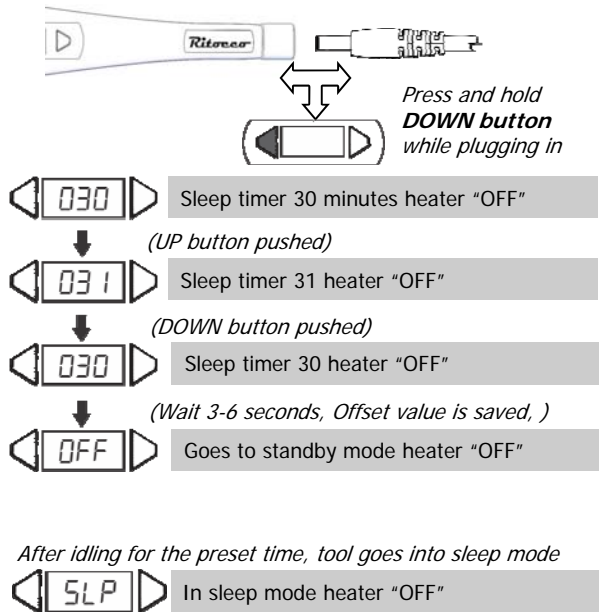

## DISPLAY AND CONTROL

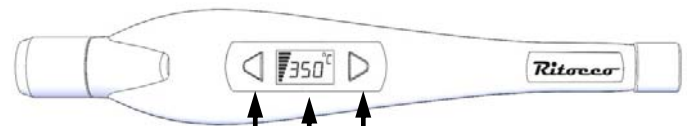

- 1 — Down Button
- 2 — LCD Display
- 3 — Up Button

- 4 — Heating power
- 5 — Mode Display
- 6 — Temperature Scale

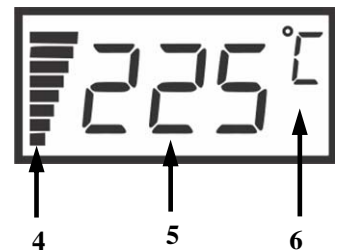

**Warning:** Never leave retouching tool unattended while in operation. Tip temperature may reach as high as 400 degrees. Only place retouching tool on non-flammable surface. Keep away from flammable and combustible objects and surfaces.

## QUICK TIP CHANGE

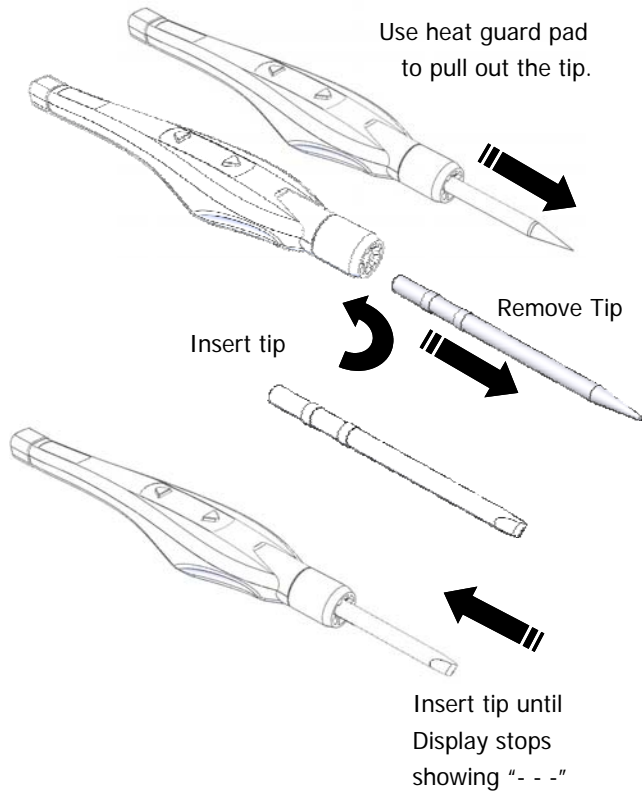

## QUICK TIP CHANGE

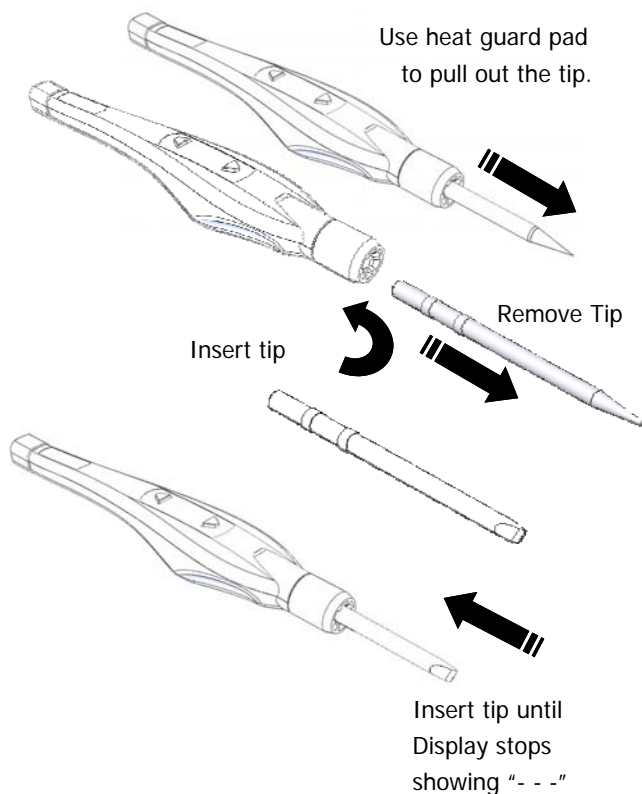

## OPERATING GUIDELINES

### SLEEP MODE

The system is equipped with a sleep function, the internal vibration sensor would be able to sense if tool is being used or not. It will enter sleep "SLP " if the system has detected tool has not be used after a preset time. Timer can be set from 1 to 60 minutes.

When system is in sleep mode the display would show the letters "SLP " shaking or picking up the tool will immediately wake the system up and return to the previously working settings.

Adjusting the Sleep:

1. Press the down button while plugging in the Ritocco the display would show a number "030" indicating this is the current set sleep timer. (default 30 minutes)
2. Press the up or down button to adjust sleep timer settings. Wait for 3—5 seconds, the system will save the new sleep settings and enter standby mode.

## OPERATING GUIDELINES

### SLEEP MODE

The system is equipped with a sleep function, the internal vibration sensor would be able to sense if tool is being used or not. It will enter sleep "SLP " if the system has detected tool has not be used after a preset time. Timer can be set from 1 to 60 minutes.

When system is in sleep mode the display would show the letters "SLP " shaking or picking up the tool will immediately wake the system up and return to the previously working settings.

Adjusting the Sleep:

1. Press the down button while plugging in the Ritocco the display would show a number "030" indicating this is the current set sleep timer. (default 30 minutes)
2. Press the up or down button to adjust sleep timer settings. Wait for 3—5 seconds, the system will save the new sleep settings and enter standby mode.

## OPERATING GUIDELINES

### From Main Menu to Digital offset Mode

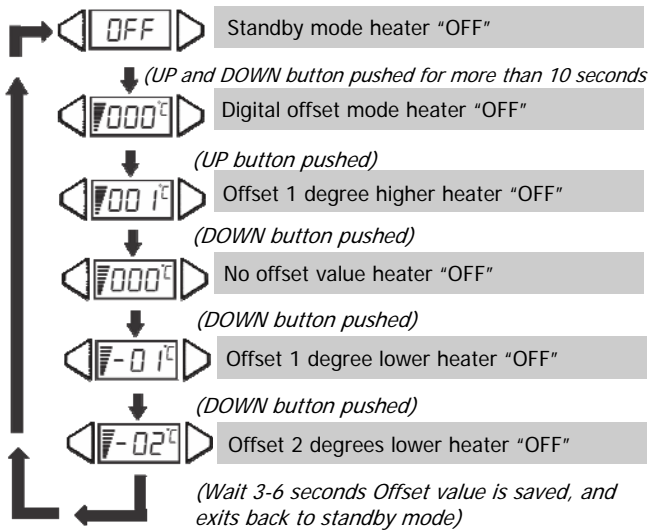

#### Example:

1. Set temperature is 200.
2. Measured temperature by external temperature probe is 220.
3. We need to offset by -20.

## OPERATING GUIDELINES

### EASY MODE

The easy mode is suited for novice users, the appropriate temperature settings has already been pre-programmed into the Ritocco, simply select what type of plastic (ABS, or PLA ) you would like to work with.

Selecting ABS or PLA working mode:

1. Plug in the Ritocco the display would show "OFF" indicating it is in the stand by mode, the heating element would not be powered.
2. Press the up or down button to select between "ABS", "PLA", or "\*\*\*\*". (\*\*\*) indicates a temperature)
3. After selecting the type of plastic to be reworked on wait for 3—6 seconds, the power level meter will start moving indicating the system is now powering the heater.
4. If working on smaller or thinner pieces the working temperature level may be lowered by pressing the down button. The temperature may be lowered up to 10 levels .
5. If working on larger or thicker pieces the working temperature level may be increased by pressing the up button. Level may be increased up to 10 notches.
6. After working, the system may be put in standby mode by simultaneously pressing both up and down buttons.
7. Unplug from power source if tool will not be used for long periods.

## OPERATING GUIDELINES

### From Main Menu to Digital offset Mode

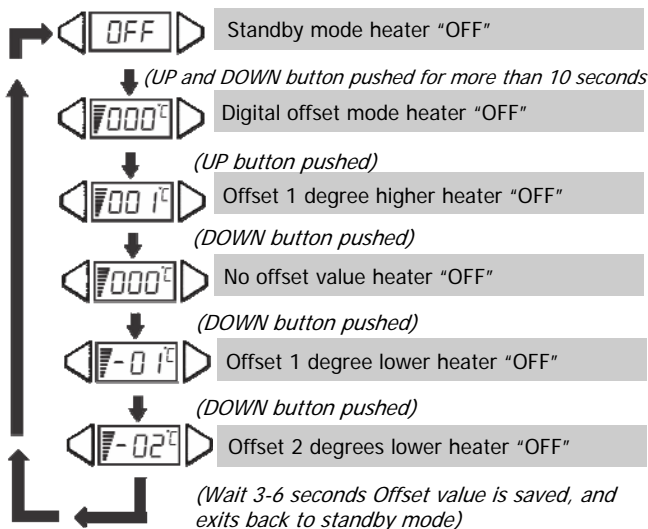

#### Example:

1. Set temperature is 200.
2. Measured temperature by external temperature probe is 220.
3. We need to offset by -20.

## OPERATING GUIDELINES

### EASY MODE

The easy mode is suited for novice users, the appropriate temperature settings has already been pre-programmed into the Ritocco, simply select what type of plastic (ABS, or PLA ) you would like to work with.

Selecting ABS or PLA working mode:

1. Plug in the Ritocco the display would show "OFF" indicating it is in the stand by mode, the heating element would not be powered.
2. Press the up or down button to select between "ABS", "PLA", or "\*\*\*\*". (\*\*\*) indicates a temperature)
3. After selecting the type of plastic to be reworked on wait for 3—6 seconds, the power level meter will start moving indicating the system is now powering the heater.
4. If working on smaller or thinner pieces the working temperature level may be lowered by pressing the down button. The temperature may be lowered up to 10 levels .
5. If working on larger or thicker pieces the working temperature level may be increased by pressing the up button. Level may be increased up to 10 notches.
6. After working, the system may be put in standby mode by simultaneously pressing both up and down buttons.
7. Unplug from power source if tool will not be used for long periods.

## OPERATING GUIDELINES

### Stand by mode -> Scroll through modes

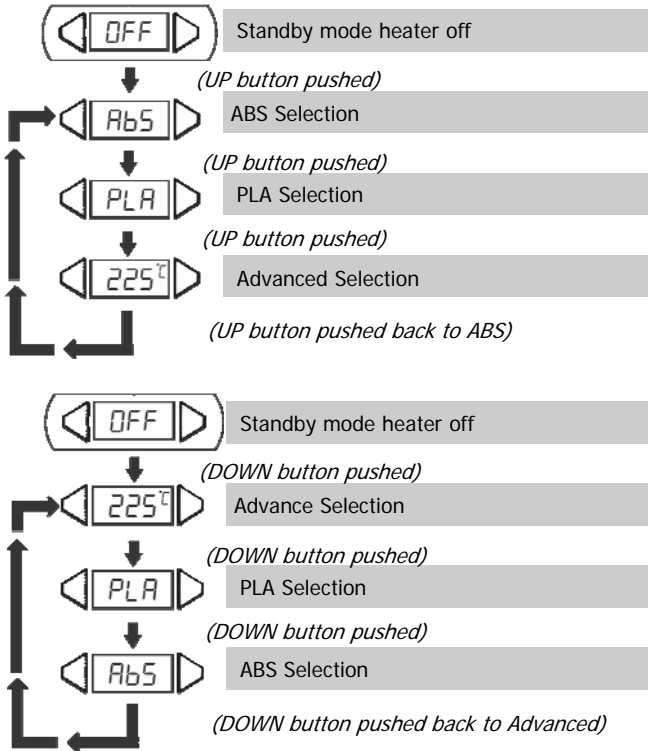

12

## OPERATING GUIDELINES

### DIGITAL OFFSET MODE

The unit is provided with a digital offset feature for tip calibration.

To calibrate the tip temperature:

1. Enter advanced mode and set to desired temperature.
2. Measure the tip temperature through an external temperature reader with a thermocouple as its sensor. Ensure the external temperature reader's sensor and the tip can keep good physical contact. Wait for the display to reach the set temperature, then allow the tip to idle at the sensor for 60 seconds for proper temperature measurement.
3. Press and hold both up and down button for more than 10 seconds to enter the digital offset mode. The display will change to 000. This denotes that we are now configuring the digital offset of the system. A display with "000" indicates that the digital offset is currently set at neutral.
4. Press the increase and decrease button to adjust the digital offset. A negative number denotes a negative offset and a positive number denotes a positive offset. Adjust the offset number depending on the difference between the measured value of the external sensor and the displayed value of the tool.

17

## OPERATING GUIDELINES

### Stand by mode -> Scroll through modes

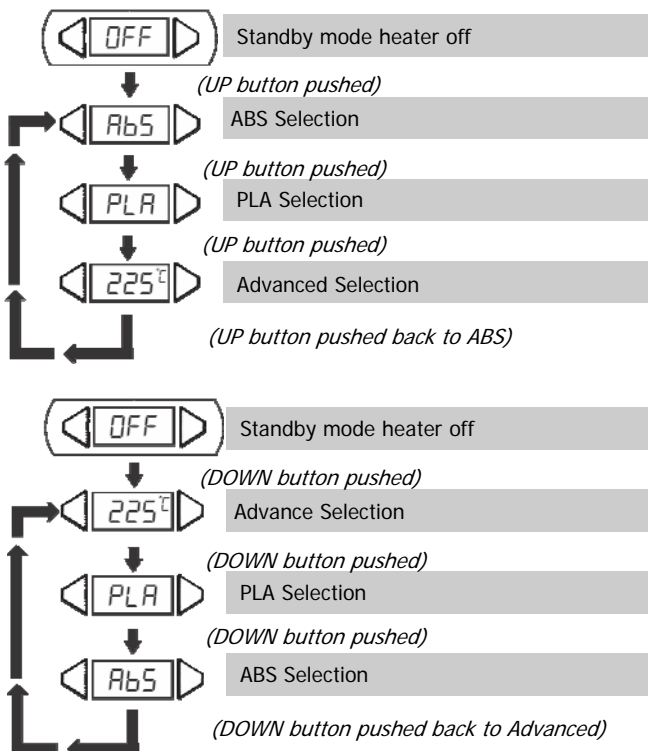

12

## OPERATING GUIDELINES

### DIGITAL OFFSET MODE

The unit is provided with a digital offset feature for tip calibration.

To calibrate the tip temperature:

1. Enter advanced mode and set to desired temperature.
2. Measure the tip temperature through an external temperature reader with a thermocouple as its sensor. Ensure the external temperature reader's sensor and the tip can keep good physical contact. Wait for the display to reach the set temperature, then allow the tip to idle at the sensor for 60 seconds for proper temperature measurement.
3. Press and hold both up and down button for more than 10 seconds to enter the digital offset mode. The display will change to 000. This denotes that we are now configuring the digital offset of the system. A display with "000" indicates that the digital offset is currently set at neutral.
4. Press the increase and decrease button to adjust the digital offset. A negative number denotes a negative offset and a positive number denotes a positive offset. Adjust the offset number depending on the difference between the measured value of the external sensor and the displayed value of the tool.

17

## OPERATING GUIDELINES

### From standby mode to Advanced Mode

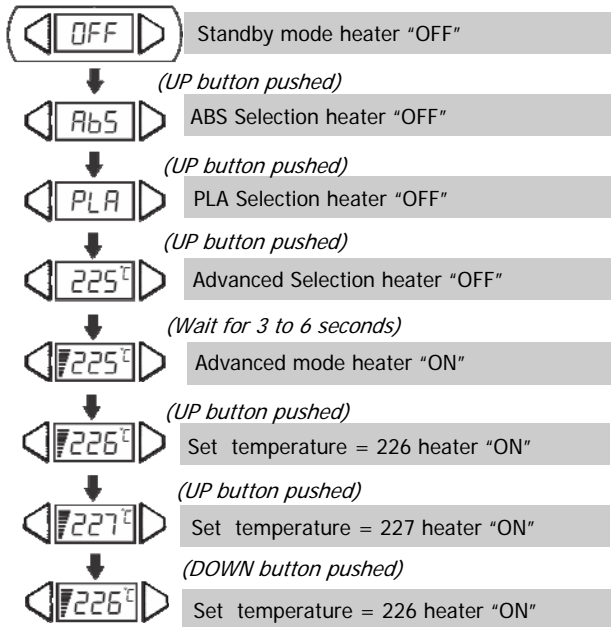

### From Advanced mode to Standby Mode

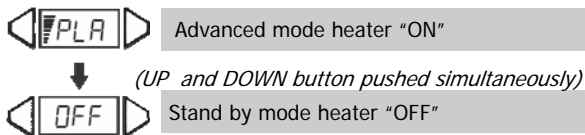

16

## OPERATING GUIDELINES

### From standby mode to ABS

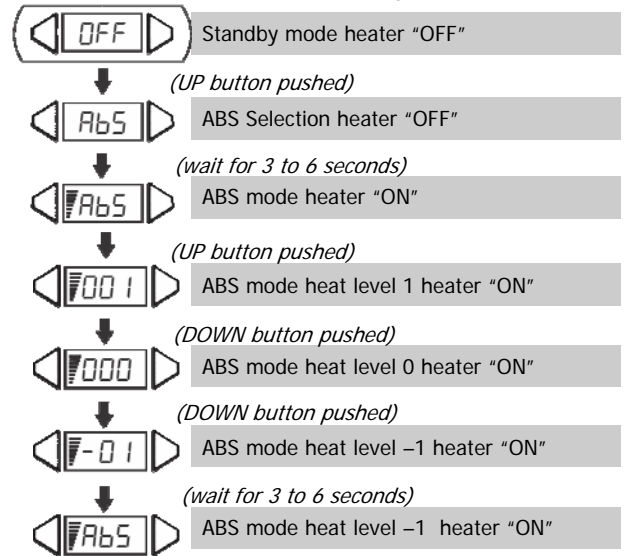

### From ABS mode to Standby Mode

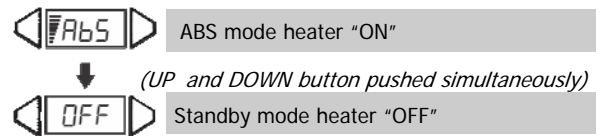

13

## OPERATING GUIDELINES

### From standby mode to Advanced Mode

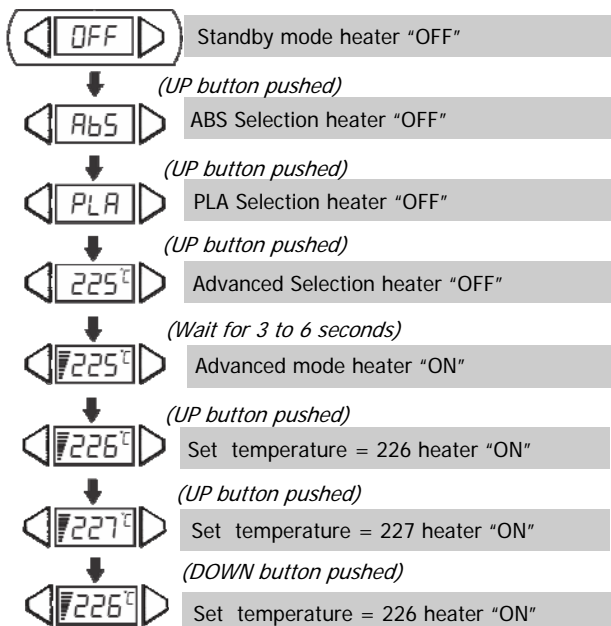

### From Advanced mode to Standby Mode

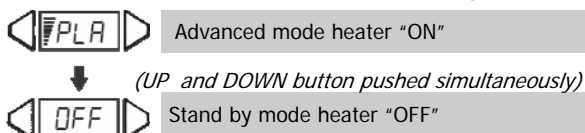

16

## OPERATING GUIDELINES

### From standby mode to ABS

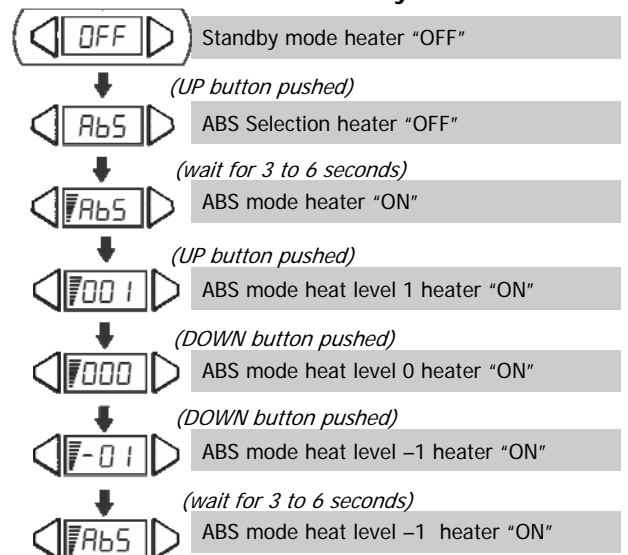

### From ABS mode to Standby Mode

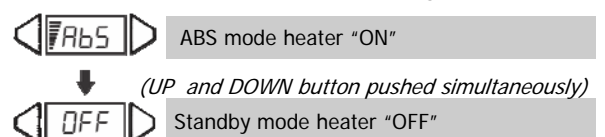

13



## OPERATING GUIDELINES

### From standby mode to PLA Mode

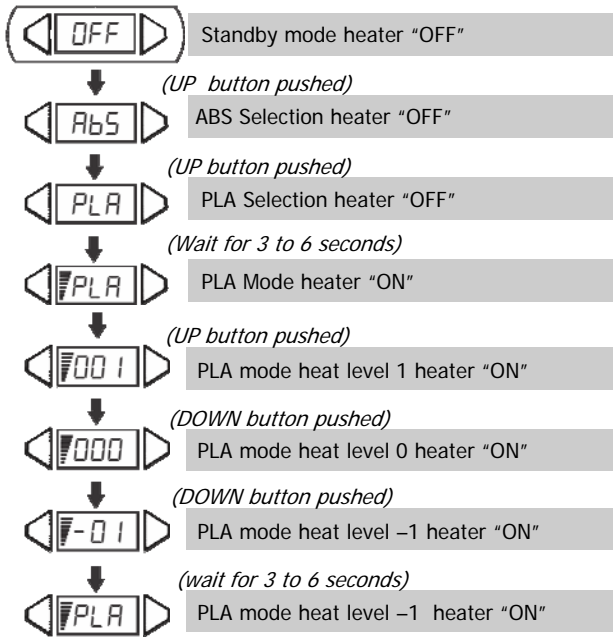

### From PLA mode to Standby Mode

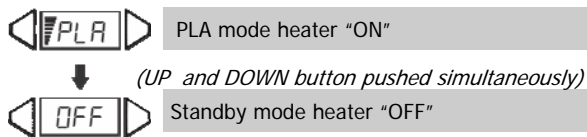

14

## OPERATING GUIDELINES

### ADVANCED MODE

The advanced mode is suited for users who already know the appropriate temperature settings for a particular plastic. Selecting Advanced working mode:

1. Plug in the Ritocco the display would show "OFF" indicating it is in the stand by mode, the heating element would not be powered.
2. Press the up or down button to select between "ABS", "PLA", or "\*\*\*\*". (\*\*\*) indicates a temperature and the advanced mode)
3. Select the mode with actual temperature display then wait for 3—6 seconds, the power level meter will start moving indicating the system is now powering the heater.
4. The actual temperature may be adjusted according to needs, temperature is adjustable from 100 to 400 degrees Celsius.
5. Display will switch from showing the set temperature to the actual temperature after a few seconds, pushing either up of down button will revert display to set temperature mode.
6. After working the system may be put in standby mode by simultaneously pressing both up and down buttons.
7. Unplug from power source if tool will not be used for long periods.

15

## OPERATING GUIDELINES

### From standby mode to PLA Mode

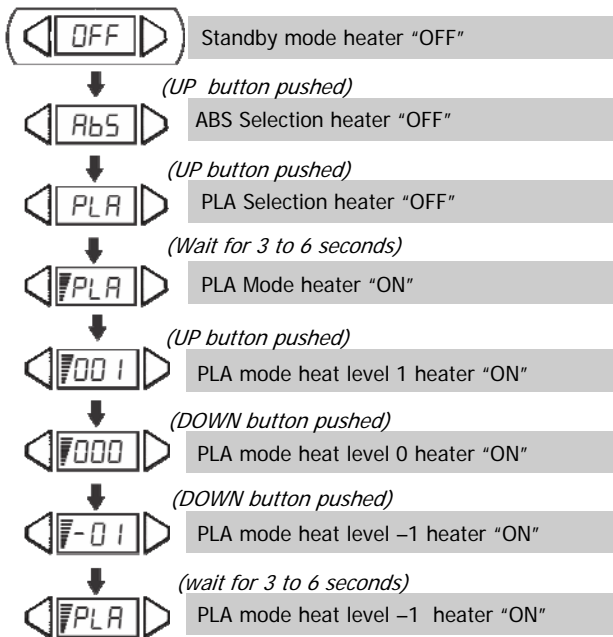

### From PLA mode to Standby Mode

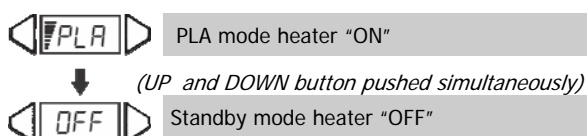

14

## OPERATING GUIDELINES

### ADVANCED MODE

The advanced mode is suited for users who already know the appropriate temperature settings for a particular plastic. Selecting Advanced working mode:

1. Plug in the Ritocco the display would show "OFF" indicating it is in the stand by mode, the heating element would not be powered.
2. Press the up or down button to select between "ABS", "PLA", or "\*\*\*\*". (\*\*\*) indicates a temperature and the advanced mode)
3. Select the mode with actual temperature display then wait for 3—6 seconds, the power level meter will start moving indicating the system is now powering the heater.
4. The actual temperature may be adjusted according to needs, temperature is adjustable from 100 to 400 degrees Celsius.
5. Display will switch from showing the set temperature to the actual temperature after a few seconds, pushing either up of down button will revert display to set temperature mode.
6. After working the system may be put in standby mode by simultaneously pressing both up and down buttons.
7. Unplug from power source if tool will not be used for long periods.

15