

THIS DRAWING IS UNPUBLISHED. RELEASED FOR PUBLICATION
 © COPYRIGHT - By - ALL RIGHTS RESERVED.

REVISIONS				
P	LTR	DESCRIPTION	DATE	APVD
B		UPDATE PER ECO-16-002588	24 FEB 16	CAS CAS

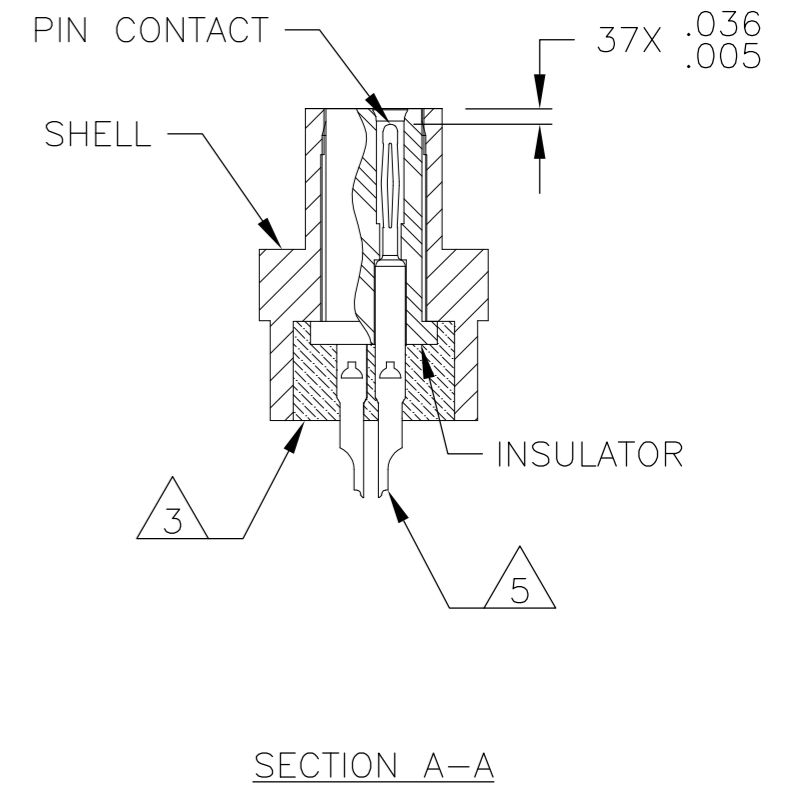
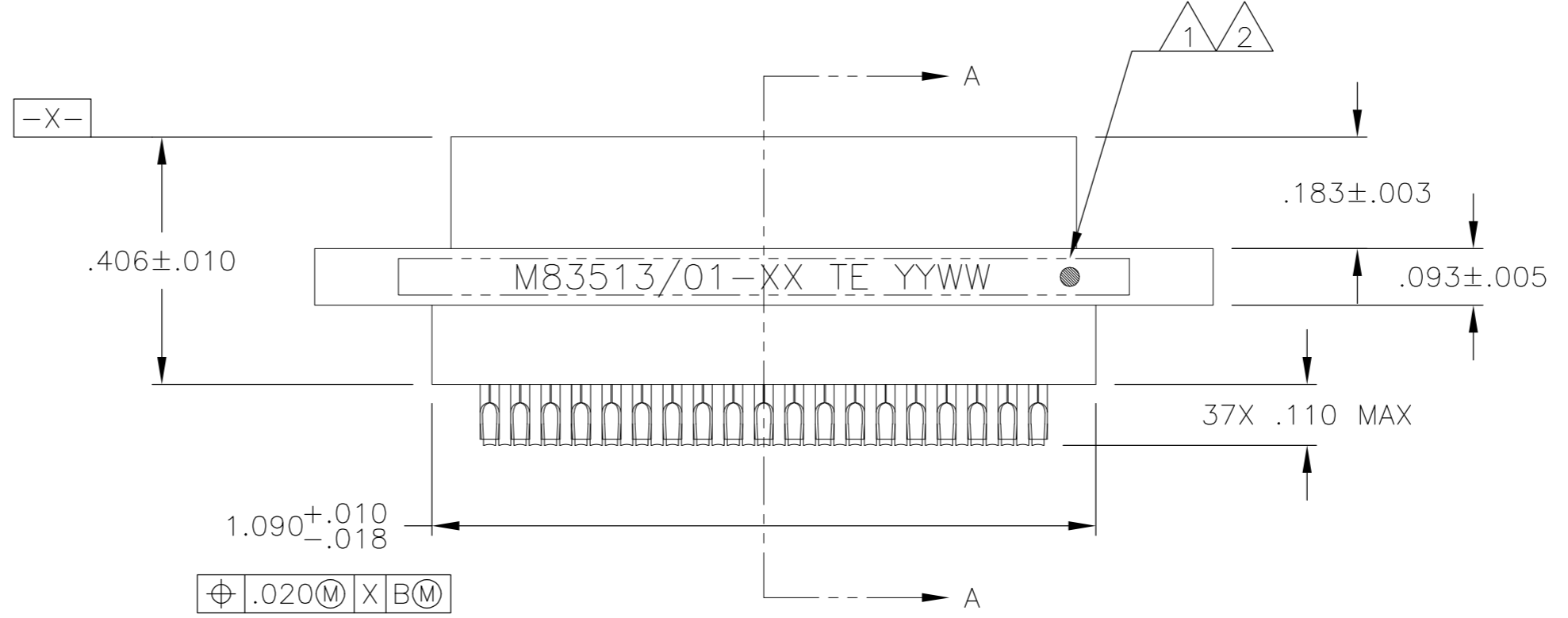
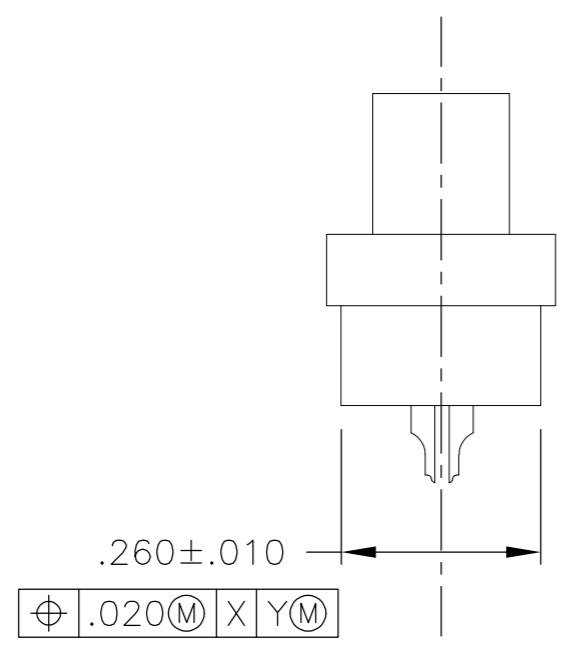
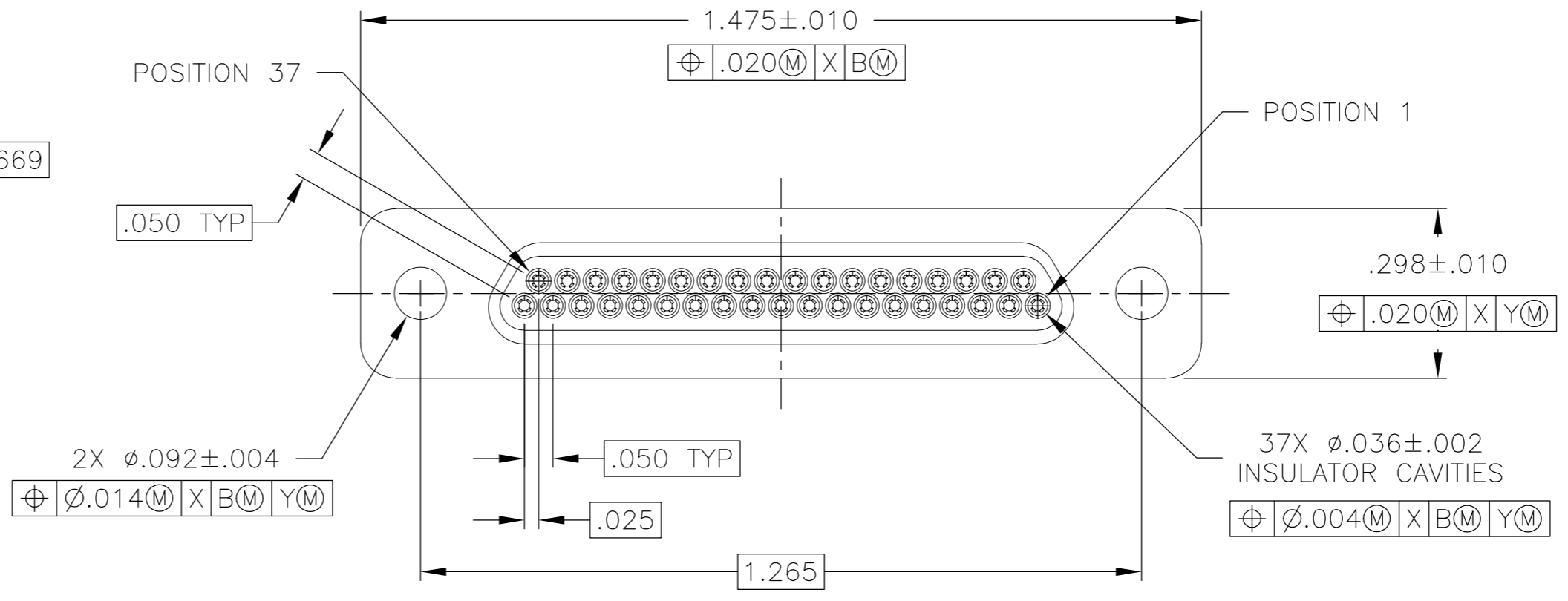
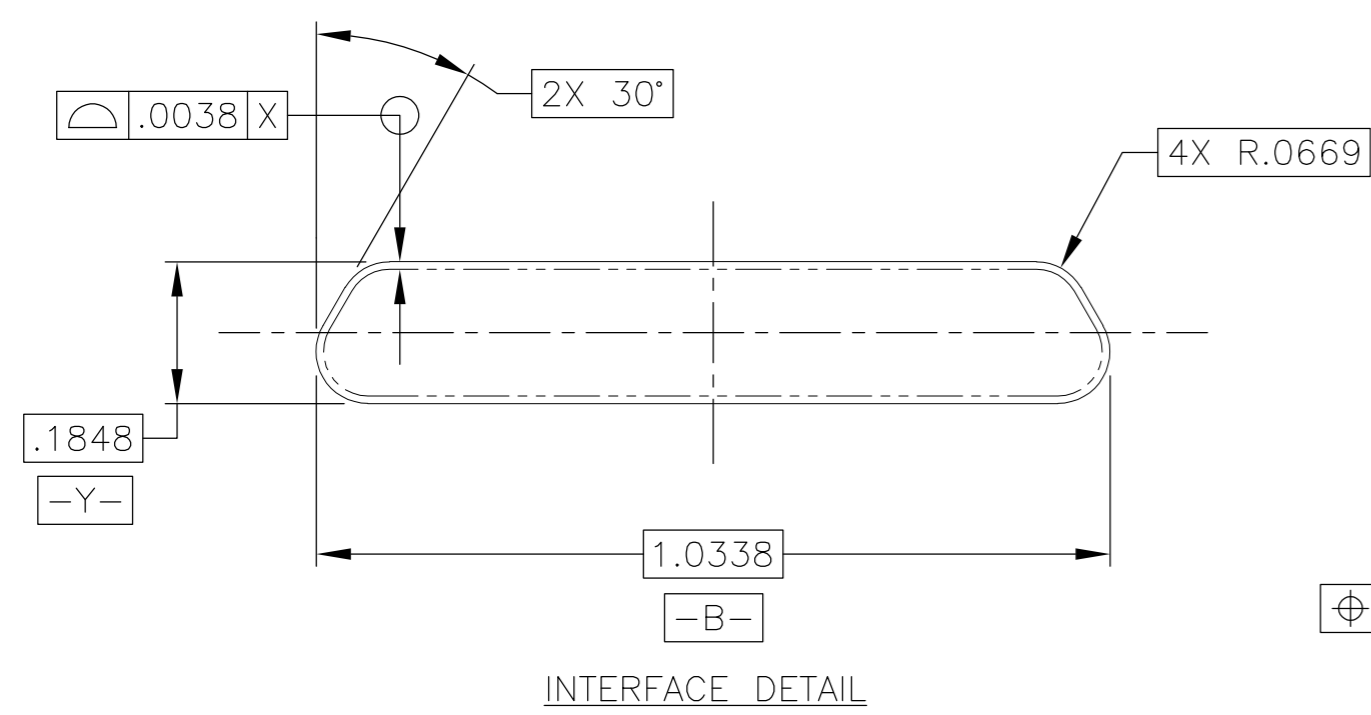

- 1 CONNECTOR SHALL BE MARKED IN ACCORDANCE WITH METHOD I OF MIL-STD-1285. MARKING SHALL CONTAIN THE MILITARY PIN, CAGE CODE (OR TE), AND DATE CODE. EXAMPLE: M83513/01-XX TE YYWW (WHERE XX IS PART OF THE PIN SHOWN IN THE "MIL-DTL-83513" COLUMN OF THE PART NUMBER TABLE, AND YYWW IS THE DATE CODE). TEXT HEIGHT SHALL BE .035 INCH MINIMUM.
- 2 POSITION 1 SHALL BE INDICATED BY AN IDENTIFIABLE MARK, LOCATED APPROXIMATELY AS SHOWN ON THE POSITION 1 SIDE OF THE CONNECTOR FLANGE. THIS MARK SHALL BE INCLUDED AS PART OF THE PART MARKING INFORMATION.
- 3 EPOXY ENCAPSULATION. EPOXY MAY WICK .050 INCH MAX FOR SOLDER CUPS.
- 4 ALL DIMENSIONS AND REQUIREMENTS ARE PER MIL-DTL-83513/1
- 5 CHAMFER ON SOLDER POTS ARE PARALLEL WITH THE SIDE OF CONNECTOR WITHIN 10°

THIS DRAWING IS A CONTROLLED DOCUMENT.		DWN B. ROMANCHUK 03 SEP 08	TE Connectivity	
DIMENSIONS: INCHES		CHK -	NAME M. STORRY 03 SEP 08	
TOLERANCES UNLESS OTHERWISE SPECIFIED:		PRODUCT SPEC		
0 PLC ± -		APPLICATION SPEC		
1 PLC ± -		WEIGHT -		
2 PLC ± .010		SIZE A2		
3 PLC ± .005		CAGE CODE 98278		
4 PLC ± -		DRAWING NO. 1532214		
ANGLES ± 1°		RESTRICTED TO -		
FINISH -		SCALE 4:1		
MATERIAL SEE NOTES		SHEET 1 of 2		
		REV B		

4

3

2

1

THIS DRAWING IS UNPUBLISHED. RELEASED FOR PUBLICATION
 © COPYRIGHT - By - ALL RIGHTS RESERVED.

REVISIONS				
P	LTR	DESCRIPTION	DATE	APVD
-		SEE SHEET 1	-	-

△₁

TE PART NUMBER	MIL-DTL-83513 PIN	MICRODOT P/N	MCKS DESCRIPTION
1532214-1	M83513/01-FN	094-6625-0000	MCKS-N1-B-37PS
1532214-2	M83513/01-FC	094-6635-0000	MCKS-C2-B-37PS

1532214

THIS DRAWING IS A CONTROLLED DOCUMENT.

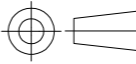
DWN B. ROMANCHUK	03 SEP 08		TE Connectivity	
CHK M. STORRY	03 SEP 08		NAME	
DIMENSIONS: INCHES		TOLERANCES UNLESS OTHERWISE SPECIFIED:		PLUG ASSEMBLY, MICRO-D PER MIL-DTL-83513/01, MCKS SERIES, 37 POSITION
	0 PLC ± - 1 PLC ± - 2 PLC ± - 3 PLC ± - 4 PLC ± - ANGLES ± -	APVD	PRODUCT SPEC	
MATERIAL	FINISH	APPLICATION SPEC	RESTRICTED TO	
-	-	WEIGHT	SCALE	
CUSTOMER DRAWING		A2	4:1	
SIZE		CAGE CODE	DRAWING NO.	
A2	98278	C-1532214	RESTRICTED TO	
SHEET			REV	
2 OF 2			B	