

Lightning/surge arrester type 1/2 - VAL-MS-T1/T2 175/12.5/3+1-FM - 2800670

Please be informed that the data shown in this PDF Document is generated from our Online Catalog. Please find the complete data in the user's documentation. Our General Terms of Use for Downloads are valid (<http://phoenixcontact.com/download>)



Universal varistor-based plug-in lightning/surge arrester for 3-phase power supply networks with separate N and PE (5-conductor system: L1, L2, L3, N, PE), for Lightning Protection Levels III and IV, with remote indication contact.

Your advantages

- ✓ Plugs can be checked with CHECKMASTER
- ✓ With floating remote indication contact
- ✓ Secure hold of plugs in the event of high lightning current loads and strong vibrations thanks to new latching
- ✓ Mechanical coding of all slots
- ✓ Optical, mechanical status indication for the individual arresters
- ✓ Pluggable
- ✓ Thermal disconnect device for each individual plug



Key Commercial Data

Packing unit	1 pc
GTIN	 4 046356 624251
GTIN	4046356624251

Technical data

Dimensions

Height	99 mm
Width	71.2 mm
Depth	77.5 mm
Horizontal pitch	4 Div.

Ambient conditions

Degree of protection	IP20 (only when all terminal points are used)
Ambient temperature (operation)	-40 °C ... 80 °C

Lightning/surge arrester type 1/2 - VAL-MS-T1/T2 175/12.5/3+1-FM - 2800670

Technical data

Ambient conditions

Ambient temperature (storage/transport)	-40 °C ... 80 °C
Altitude	≤ 2000 m (amsl (above mean sea level))
Permissible humidity (operation)	5 % ... 95 %
Shock (operation)	30g (Half-sine / 11 ms / 3x ±X, ±Y, ±Z)
Vibration (operation)	7.5g (10 ... 500 Hz / 2.5 h / X, Y, Z)

General

IEC test classification	I / II
	T1 / T2
	T1
	I
EN type	T1 / T2
	T1
IEC power supply system	TT
	TN-C
	TN-S
Mode of protection	L-N
	L-PE
	N-PE
Mounting type	DIN rail: 35 mm
Color	jet black RAL 9005
Housing material	PA 6.6
	PBT
Degree of pollution	2
Flammability rating according to UL 94	V-0
Type	DIN rail module, two-section, divisible
Surge protection fault message	Optical, remote indicator contact

Additional descriptions

Note	Nominal voltage UN = 120 V AC/240 V AC split-phase (separate GND)
------	---

Protective circuit

Nominal voltage U_N	120/208 V AC (TN-S)
	120/208 V AC (TT)
Nominal frequency f_N	50 Hz (60 Hz)
Maximum continuous operating voltage U_C (L-N)	175 V AC
Maximum continuous operating voltage U_C (L-PE)	175 V AC
Maximum continuous voltage U_C (N-PE)	264 V AC
Rated load current I_L	80 A
Residual current I_{PE}	≤ 5 μA
Standby power consumption P_C	≤ 420 mVA

Lightning/surge arrester type 1/2 - VAL-MS-T1/T2 175/12.5/3+1-FM - 2800670

Technical data

Protective circuit

Nominal discharge current I_n (8/20) μs (L-N)	12.5 kA
Nominal discharge current I_n (8/20) μs (L-PE)	12.5 kA
Nominal discharge current I_n (8/20) μs (N-PE)	50 kA
Maximum discharge current I_{max} (8/20) μs	50 kA
Impulse discharge current (10/350) μs (L-N), charge	6.25 As
Impulse discharge current (10/350) μs (L-N), specific energy	39 kJ/ Ω
Impulse discharge current (10/350) μs (L-N), peak current value I_{imp}	12.5 kA
Impulse discharge current (10/350) μs (L-PE), charge	6.25 As
Impulse discharge current (10/350) μs (L-PE), specific energy	39 kJ/ Ω
Impulse discharge current (10/350) μs (L-PE), peak current value I_{imp}	12.5 kA
Impulse discharge current (10/350) μs (N-PE), charge	25 As
Impulse discharge current (10/350) μs (N-PE), specific energy	625 kJ/ Ω
Impulse discharge current (10/350) μs (N-PE), peak current value I_{imp}	50 kA
Total discharge current I_{total} (8/20) μs	50 kA
Total discharge current I_{total} (10/350) μs	50 kA
Follow current interrupt rating I_{fi} (N-PE)	100 A (264 V AC)
Short-circuit current rating I_{SCCR}	25 kA
Voltage protection level U_p (L-N)	≤ 0.8 kV
Voltage protection level U_p (L-PE)	≤ 2 kV
Voltage protection level U_p (N-PE)	≤ 1.7 kV
Residual voltage U_{res} (L-N)	≤ 0.8 kV (at I_n)
	≤ 0.75 kV (at 10 kA)
	≤ 0.65 kV (at 5 kA)
	≤ 0.6 kV (at 3 kA)
Residual voltage U_{res} (L-PE)	≤ 2 kV (at I_n)
	≤ 1.5 kV (at 10 kA)
	≤ 1.4 kV (at 5 kA)
	≤ 1.3 kV (at 3 kA)
Residual voltage U_{res} (N-PE)	≤ 0.6 kV (at I_n)
	≤ 0.5 kV (at 10 kA)
	≤ 0.5 kV (at 5 kA)
	≤ 0.4 kV (at 3 kA)
TOV behavior at U_T (L-N)	208 V AC (5 s / withstand mode)
	229 V AC (120 min / withstand mode)
TOV behavior at U_T (N-PE)	1200 V AC (200 ms / withstand mode)
Response time t_A (L-N)	≤ 25 ns
Response time t_A (L-PE)	≤ 100 ns
Response time t_A (N-PE)	≤ 100 ns

Lightning/surge arrester type 1/2 - VAL-MS-T1/T2 175/12.5/3+1-FM - 2800670

Technical data

Protective circuit

Max. backup fuse with V-type through wiring	80 A (gG - 16 mm ²)
Max. backup fuse with branch wiring	160 A (gG)

Indicator/remote signaling

Switching function	PDT contact
Operating voltage	5 V AC ... 250 V AC
	30 V DC
Operating current	5 mA AC ... 1.5 A AC
	1 A DC
Connection method	Screw connection
Screw thread	M2
Tightening torque	0.25 Nm
Stripping length	7 mm
Conductor cross section flexible	0.14 mm ² ... 1.5 mm ²
Conductor cross section solid	0.14 mm ² ... 1.5 mm ²
Conductor cross section AWG	28 ... 16

Connection data

Connection method	Screw connection
Screw thread	M5
Tightening torque	4.5 Nm
Stripping length	16 mm
Conductor cross section flexible	1.5 mm ² ... 25 mm ²
Conductor cross section solid	1.5 mm ² ... 35 mm ²
Conductor cross section AWG	15 ... 2

UL specifications

SPD Type	4CA
Maximum continuous operating voltage MCOV (L-L)	350 V AC
Maximum continuous operating voltage MCOV (L-N)	175 V AC
Maximum continuous operating voltage MCOV (L-G)	175 V AC
Maximum continuous operating voltage MCOV (N-G)	264 V AC
Nom. voltage	120/208 V AC
Mode of protection	L-L
	L-N
	L-G
	N-G
Power distribution system	Wye
Nominal frequency	50/60 Hz
Measured limiting voltage MLV (L-L)	2800 V
Measured limiting voltage MLV (L-N)	2200 V

Lightning/surge arrester type 1/2 - VAL-MS-T1/T2 175/12.5/3+1-FM - 2800670

Technical data

UL specifications

Measured limiting voltage MLV (L-G)	3160 V
Measured limiting voltage MLV (N-G)	2600 V
Nominal discharge current I _n (L-L)	20 kA
Nominal discharge current I _n (L-N)	20 kA
Nominal discharge current I _n (L-G)	20 kA
Nominal discharge current I _n (N-G)	20 kA

UL indicator/remote signaling

Operating voltage	125 V AC
Operating current	1 A AC
Tightening torque	4 lb _F -in.
Conductor cross section AWG	30 ... 14

UL connection data

Conductor cross section AWG	10 ... 2
Tightening torque	30 lb _F -in.

Standards and Regulations

Standards/regulations	IEC 61643-11 2011
	EN 61643-11 2012

Environmental Product Compliance

China RoHS	Environmentally friendly use period: unlimited = EFUP-e
	No hazardous substances above threshold values

Drawings

Lightning/surge arrester type 1/2 - VAL-MS-T1/T2 175/12.5/3+1-FM - 2800670

Dimensional drawing

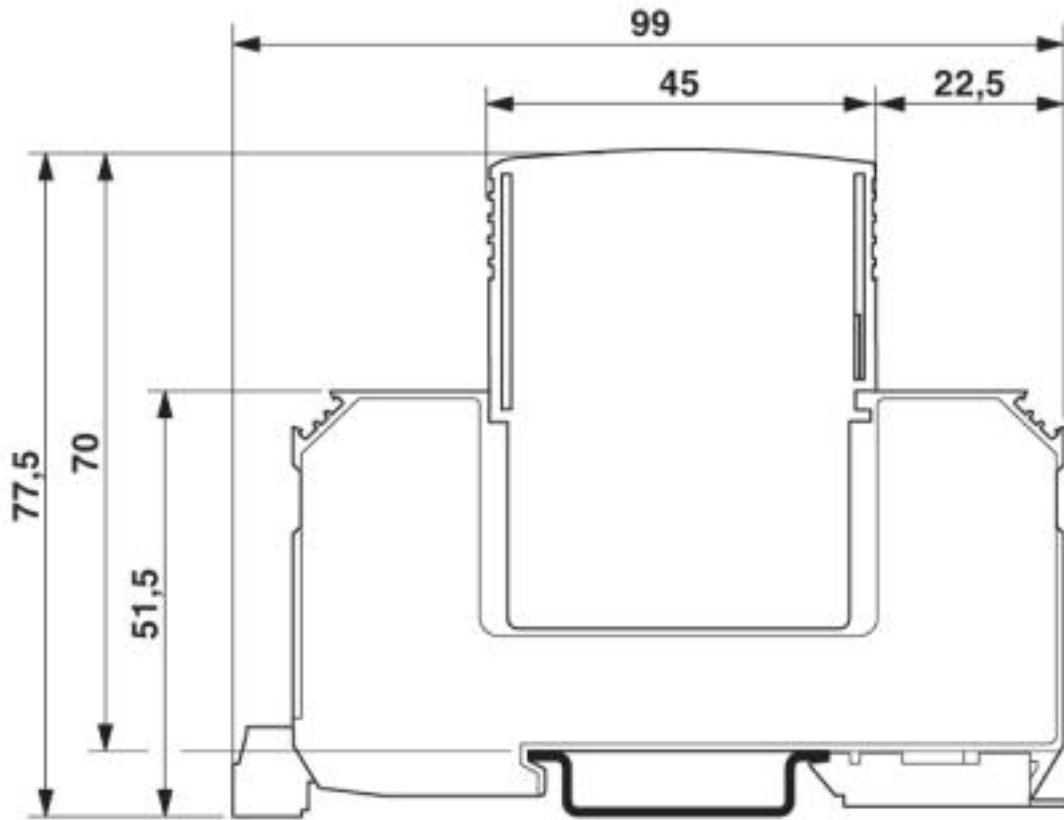

Lightning/surge arrester type 1/2 - VAL-MS-T1/T2 175/12.5/3+1-FM - 2800670

Circuit diagram

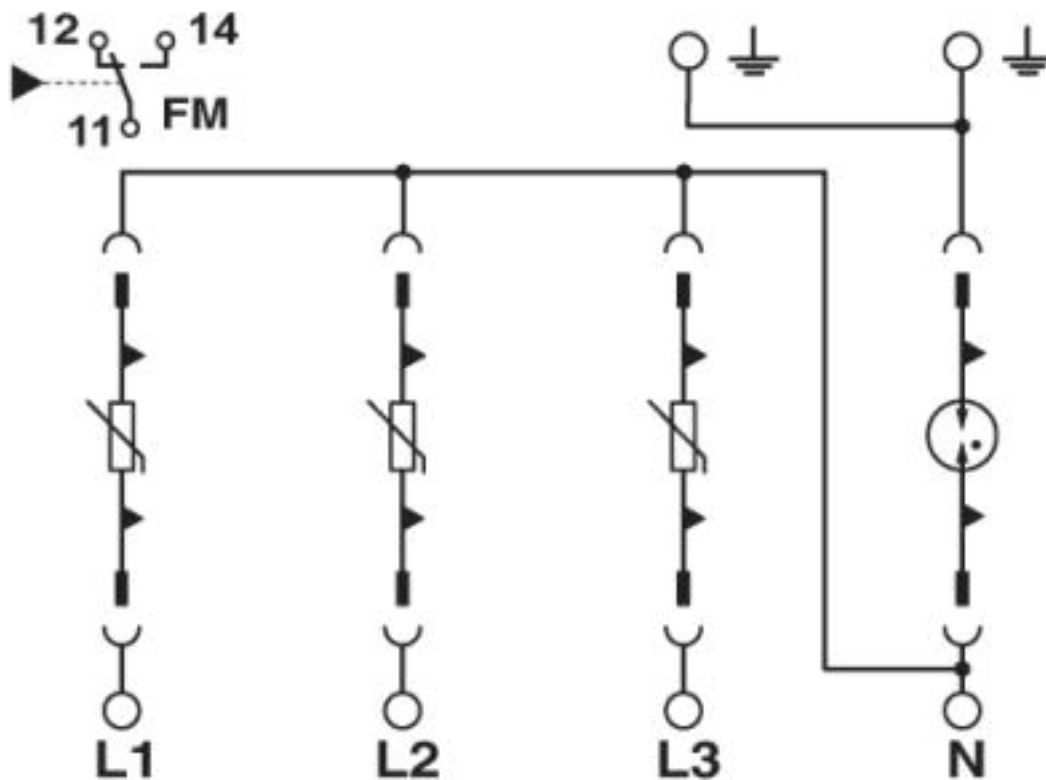

Phoenix Contact 2019 © - all rights reserved
<http://www.phoenixcontact.com>

PHOENIX CONTACT GmbH & Co. KG
Flachsmarktstr. 8
32825 Blomberg
Germany
Tel. +49 5235 300
Fax +49 5235 3 41200
<http://www.phoenixcontact.com>