

REVISIONS					
REV	ECO	DESCRIPTION	DATE	BY	APPR
B1	-	RELEASED DRAWING	AUG-08-2014	BEN	TOMMY

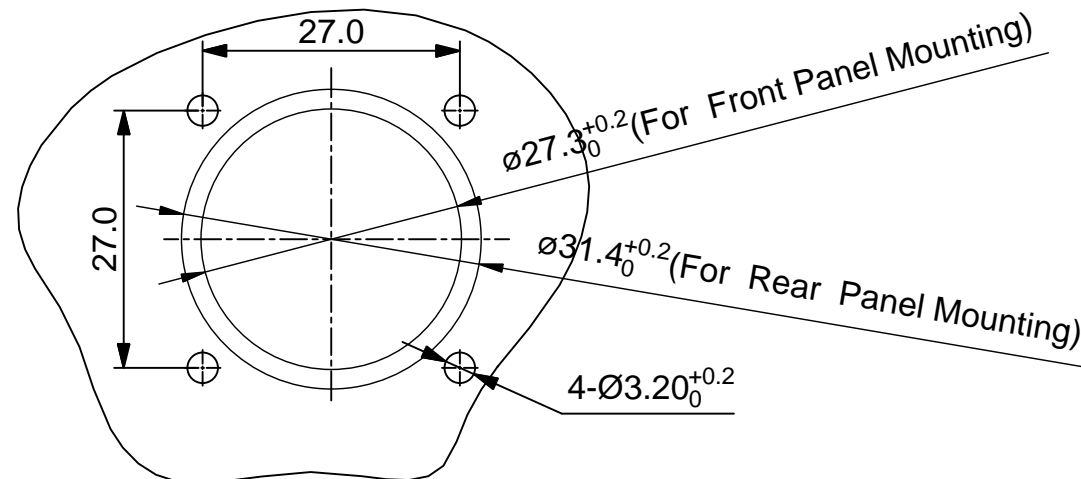
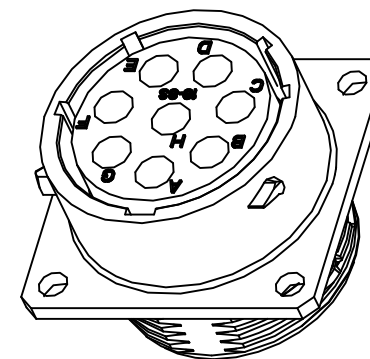
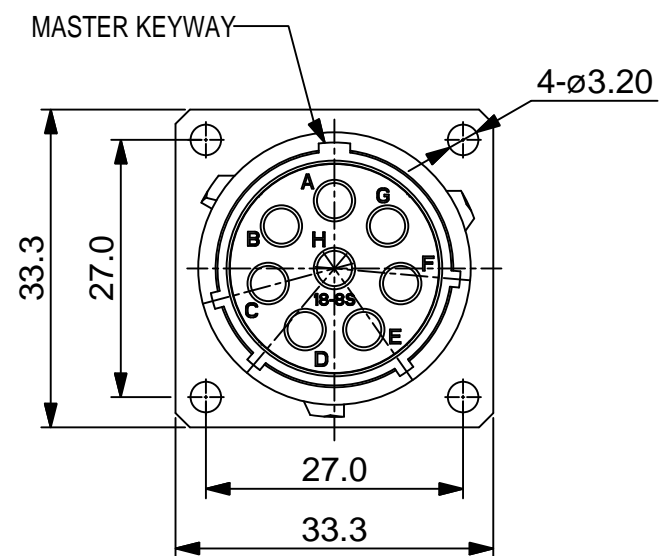
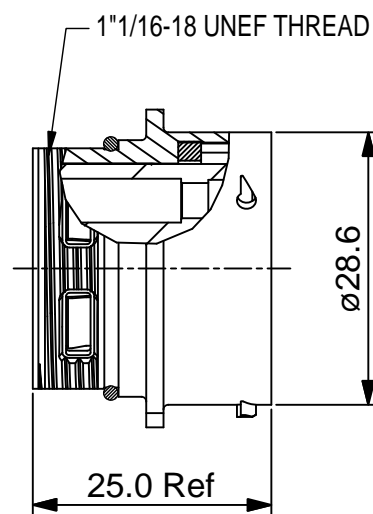

KEY POS	PART NUMBER
N	RT00188SNH
W	RT00188SWH
X	RT00188SXH
Y	RT00188SYH
Z	RT00188SZH

NOTES : (UNLESS OTHERWISE SPECIFIED)

- MATERIAL :
SHELL : ZINC ALLOY , NICKEL PLATED.
INSERT : THERMOPLASTIC , UL94 V-0.
SEAL GASKET : NBR.
O-RING : NBR.
- SPECIFICATIONS :
2.1 RATED CURRENT : 23A (MAX).
2.2 RATED VOLTAGE : 375V (AC/DC).
2.3 OPERATING TEMPERATURE : -40°C ~ +105°C.
2.4 DIELECTRIC WITHSTANDING VOLTAGE : LESS THAN 2 MILLIAMPS CURRENT LEAKAGE@2000 VOLTS AC.
2.5 INSULATION RESISTANCE : 5000 MEGOHMS MIN.
2.6 IP--CLASS : IP67.
2.7 MATING CYCLES DURABILITY : 500 CYCLES MIN.
2.8 ROHS COMPLIANT.
- SUITABLE CONTACTS : 2.5mm CONTACTS.
- ALL DIMENSIONS ARE FOR REFERENCE USE ONLY.

PANEL CUT OUT REFERENCE

QUANTITY	SEE PART NUMBER PART NUMBER	DESCRIPTION	ITEM								
MATERIALS LIST											
UNLESS OTHERWISE SPECIFIED 1) All dimensions are in metric (mm). 2) Tolerances are as follows: 1 PL DEC ±0.30 2 PL DEC ±0.15 3 PL DEC ±0.08 Fractions ±1/64 Angles ±1° 3) Note reference =		SIGNATURES DRAWN: BEN CHECKED: ENGINEER: APPROVAL:	DATE AUG-08-2014								
MATERIAL SPECIFICATIONS:		<p style="text-align: center;">Amphenol</p> <p>Sine Systems - www.amphenol-sine.com 44724 Morley Drive Clinton Township, MI 48036</p> <p style="text-align: center;">ECO-MATE, RECEPTACLE, SIZE 18,8POS, SOCKET.</p>									
PROCESS SPECIFICATIONS:											
NEXT ASSY:		CUSTOMER: THIS DRAWING IS SUPPLIED FOR INFORMATION ONLY. DESIGN FEATURES, SPECIFICATIONS AND PERFORMANCE DATA SHOWN HEREON ARE THE PROPERTY OF THE AMPHENOL CORPORATION. NO RIGHTS OF REPRODUCTION ARE IMPLIED. ALL DIMENSIONS ARE SUBJECT TO NORMAL MANUFACTURING VARIATIONS.	<table border="1"> <tr> <td>SIZE</td> <td>TYPE</td> <td>DWG NO.</td> <td>REVISION</td> </tr> <tr> <td>B</td> <td>C-</td> <td>RT00188S*H</td> <td>B1</td> </tr> </table>	SIZE	TYPE	DWG NO.	REVISION	B	C-	RT00188S*H	B1
SIZE	TYPE	DWG NO.	REVISION								
B	C-	RT00188S*H	B1								
SCALE: NONE		SHEET 1 OF 1									

TITLE: ECO-MATE RECEPTACLE SIZE 18,8POS, SOCKET. DWG NO: RT00188S*H REV: B1 SH: 1 OF: 1