

Lead taping radial lead type

● Dimensions

Case size(mm) $\phi D \times L$	Lead space	2.5 mm	5.0 mm	7.5 mm
	Figure	Figure	Figure	Figure
4 × 5, 7	B	A	—	—
5 × 5, 7	B	A	—	—
6.3 × 5, 7	C	A	—	—
8 × 5, 7	C	E	—	—
5 × 11	C	D	—	—
6.3 × 11.2, 15	C	D	—	—

Case size(mm) $\phi D \times L$	Lead space	2.5 mm	5.0 mm	7.5 mm
	Figure	Figure	Figure	Figure
8 × 11.5, 15, 20	—	E	—	—
10 × 12.5, 16, 20, 25	—	F	—	—
12.5 × 15, 20, 25	—	G	—	—
16 × 15, 20, 25	—	—	—	H
18 × 15, 20, 25	—	—	—	H

Figure A (Lead space : 5.0 mm / $\phi D \times L$: $\phi 4 \times 5, 7, \phi 5 \times 5, 7, \phi 6.3 \times 5, 7$)

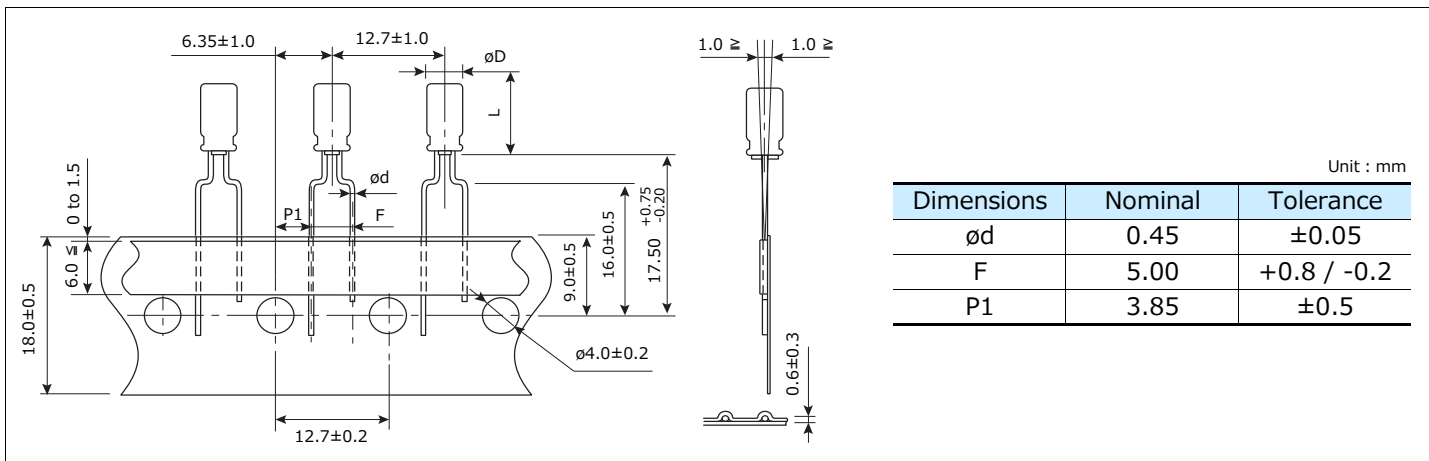

Figure B (Lead space : 2.5 mm / $\phi D \times L$: $\phi 4 \times 5, 7, \phi 5 \times 5, 7$)

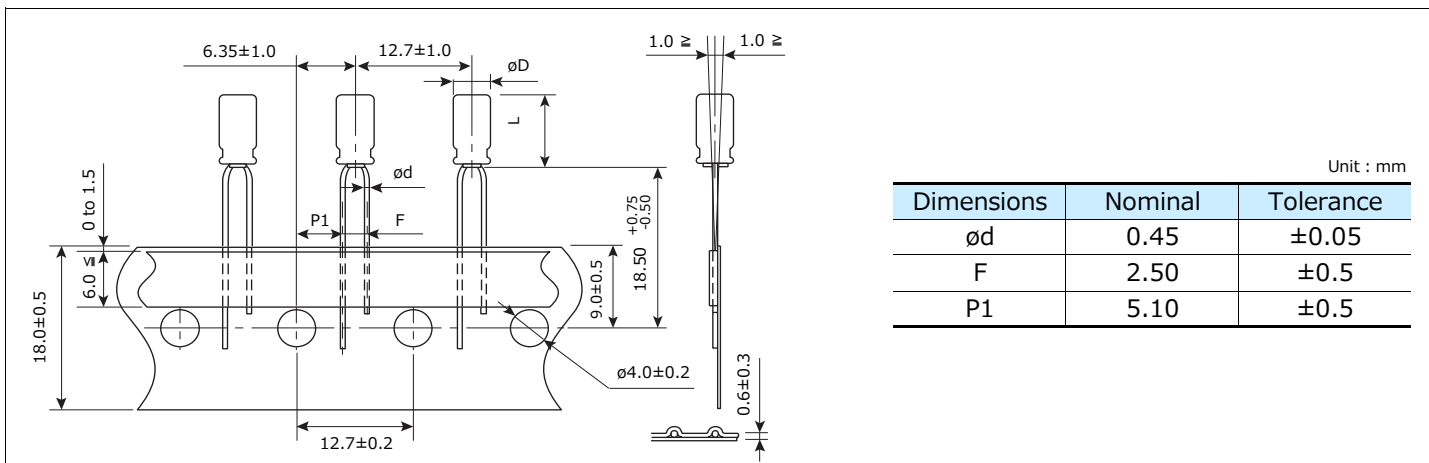

Figure C (Lead space : 2.5 mm / $\phi D \times L$: $\phi 5 \times 11, \phi 6.3 \times 5, 7, 11.2, 15, \phi 8 \times 5, 7$)

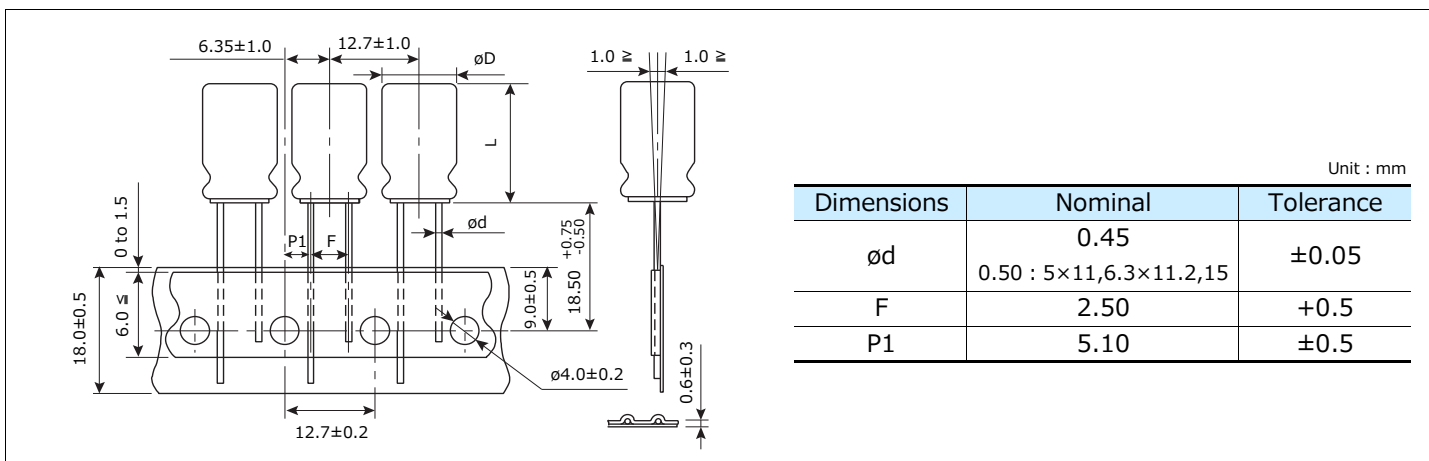

Figure D (Lead space : 5.0 mm / $\phi D \times L$: $\phi 5 \times 11, \phi 6.3 \times 11.2, 15$)

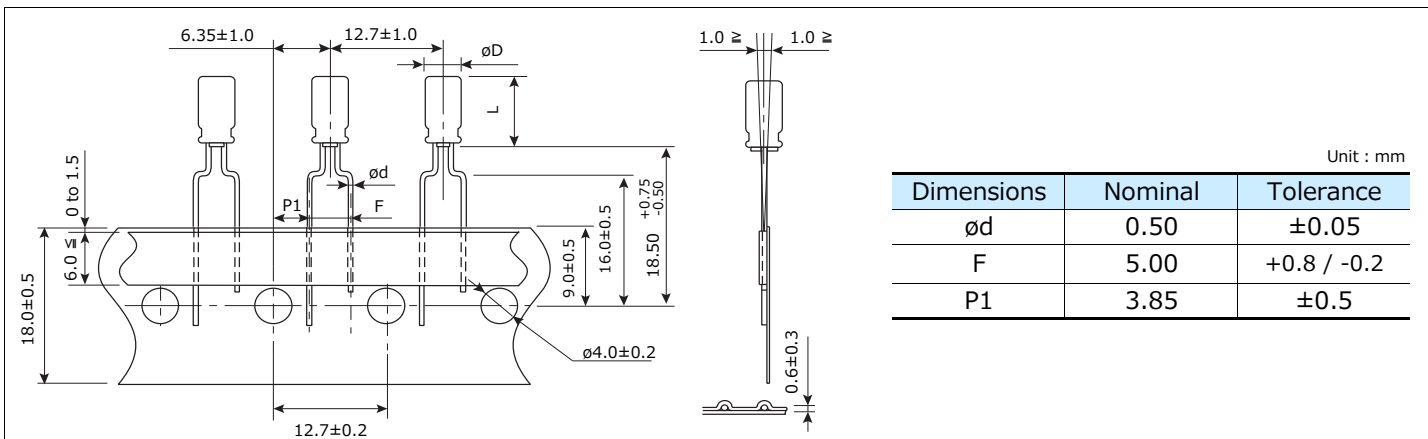

Figure E (Lead space : 5 mm / $\phi D \times L$: $\phi 8 \times 5, 7, 11.5, 15, 20$)

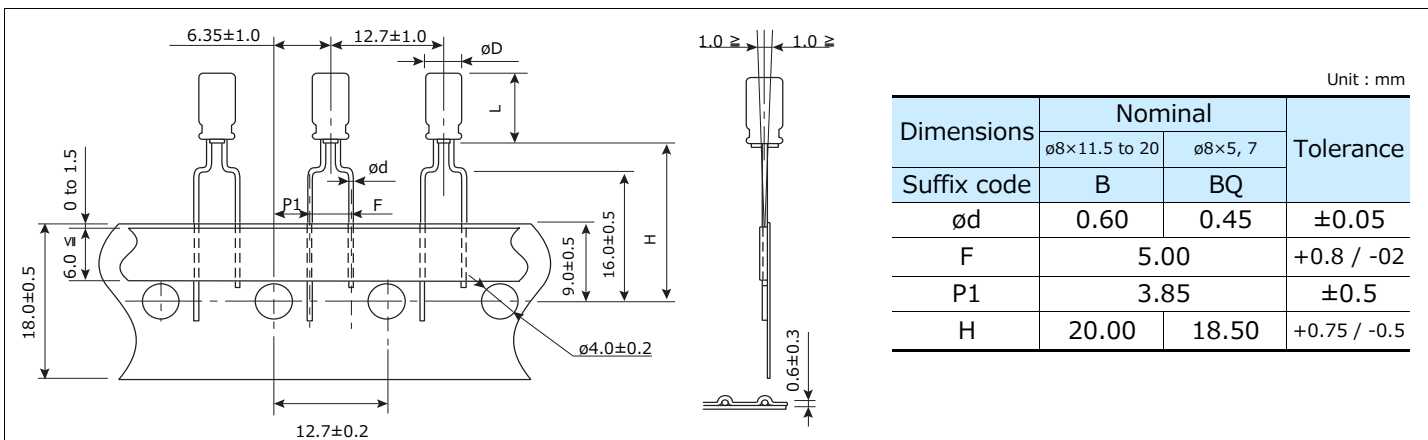

Figure F (Lead space : 5 mm / $\phi D \times L$: $\phi 10 \times 12.5, 16, 20, 25$)

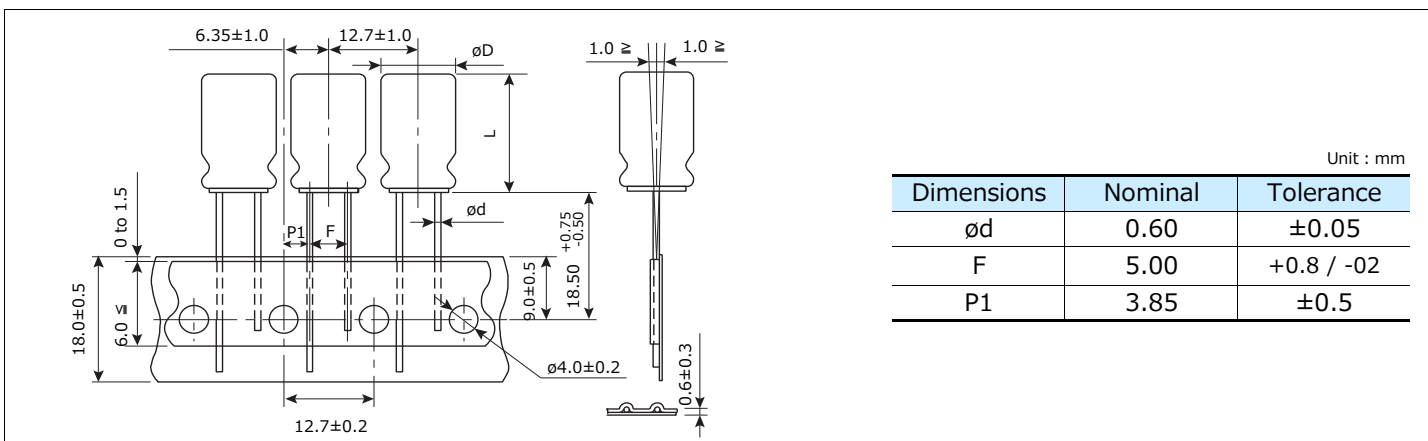

Figure G (Lead space : 5 mm / $\phi D \times L$: $\phi 12.5 \times 15, 20, 25$)

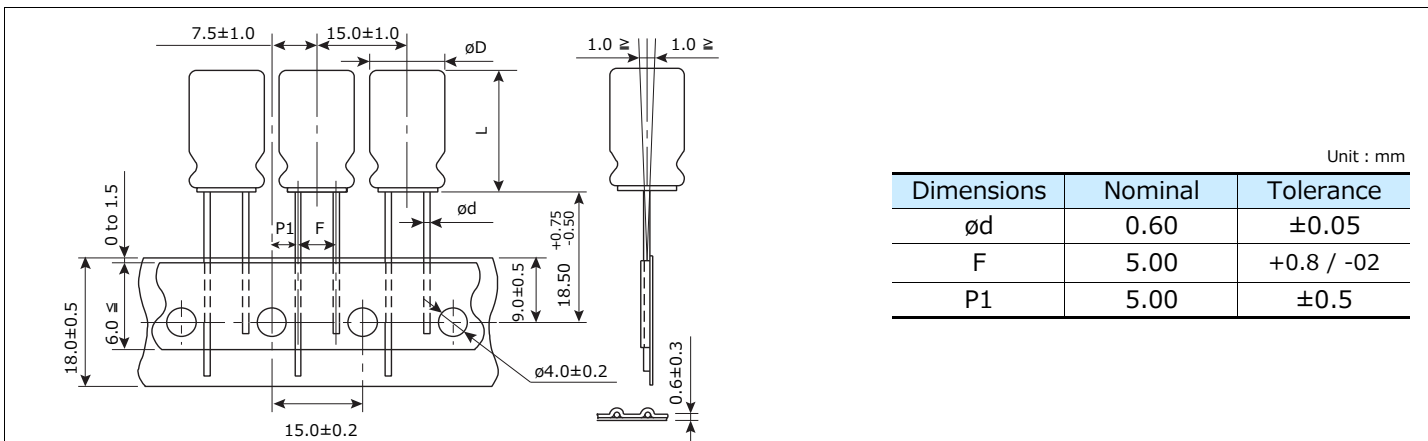
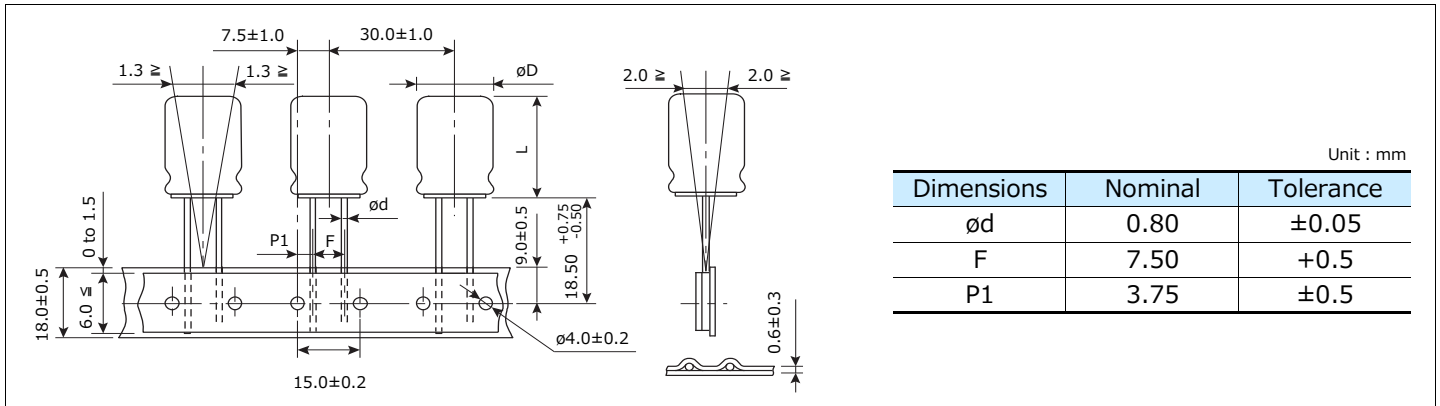

Figure H (Lead space : 7.5 mm / $\phi D \times L$: $\phi 16 \times 15, 20, 25, \phi 18 \times 15, 20, 25$)



Packaging Specifications

Unit : mm

Dimensions of outer carton box	Dimensions					
	$\phi 4$ to $\phi 5$	$\phi 6.3$	$\phi 8$	$\phi 10, \phi 12.5$	$\phi 16, \phi 18$	
a	340 max.	340 max.	340 max.	340 max.	340 max.	
b	to 55 max.	to 55 max.	to 55 max.	55 to 66 max.	62 to 75 max.	
c	170 to 210 max.	270 max.	230 max.	170 to 270 max.	225 to 310 max.	
Packaging Qty.	2000 pcs.	2000 pcs.	1000 pcs.	500 pcs.	250 pcs.	

● Lead forming type (Snap-in)

Lead formed Aluminium Electrolytic Capacitor for self mounting, for rationalization and upgrade of soldering process.

Shape of lead wire

ϕD	Dimensions
4, 5, 6.3, 8	
10, 12.5, 16, 18	

Dimensions

Unit : mm

ϕD	$H1 \pm 0.5$	H2	H3	$F \pm 0.5$	P	E max.	ϕd	for PWB	
								hole dia. ϕ	thick ness
5.0	4.5	2.7	2.5	5.0	1.0	1.0	0.5	0.9	1.6
6.3	4.5	2.7	2.5	5.0	1.0	1.0	0.5	1.0	1.6
8.0	4.5	2.7	2.5	5.0	1.0	1.0	0.6	1.0	1.6
10.0	4.5	2.7	—	5.0	1.0	1.0	0.6	1.0	1.6
12.5	4.5	2.7	—	5.0	1.0 / 0.9	1.0	0.6 / 0.8	1.0 / 1.1	1.6
16.0	4.5	2.7	—	7.5	0.9	1.0	0.8	1.1	1.6
18.0	4.5	2.7	—	7.5	0.9	1.0	0.8	1.1	1.6

Series KA/KS Dimensions

Unit : mm

ϕD	$H1 \pm 0.5$	H2	$H3 \pm 0.3$	$F \pm 0.5$	P	E max.	ϕd	for PWB	
								hole dia. ϕ	thick ness
4.0	4.5	2.7	1.5	5.0	0.95	1.0	0.45	0.9	1.6
5.0	4.5	2.7	1.5	5.0	0.95	1.0	0.45	0.9	1.6
6.3	4.5	2.7	1.5	5.0	0.95	1.0	0.45	0.9	1.6
8.0	4.5	2.7	1.5	5.0	0.95	1.0	0.45	0.9	1.6