

NLSX4302E

2-Bit 20 Mb/s Dual-Supply Level Translator

The NLSX4302E is a 2-bit configurable dual-supply bidirectional auto sensing translator that does not require a directional control pin. The V_{CC} I/O and V_L I/O ports are designed to track two different power supply rails, V_{CC} and V_L respectively. Both the V_{CC} and V_L supply rails are configurable from 1.5 V to 5.5 V. This allows voltage logic signals on the V_L side to be translated into lower, higher or equal value voltage logic signals on the V_{CC} side, and vice-versa.

The NLSX4302E translator uses external pull-up resistors on the I/O lines. The external pull-up resistors are used to pull up the I/O lines to either V_L or V_{CC} . The NLSX4302E is an excellent match for open-drain applications such as the I²C communication bus.

Features

- V_L can be Less than, Greater than or Equal to V_{CC}
- Wide V_{CC} Operating Range: 1.5 V to 5.5 V
Wide V_L Operating Range: 1.5 V to 5.5 V
- High-Speed with 20 Mb/s Guaranteed Data Rate
- Low Bit-to-Bit Skew
- Enable Input and I/O Pins are Overvoltage Tolerant (OVT) to 5.5 V
- Non-preferential Powerup Sequencing
- Power-Off Protection
- Small Space Saving Package: 1.4 mm x 1.2 mm UQFN8 Package
- These Devices are Pb-Free and are RoHS Compliant

Typical Applications

- I²C, SMBus
- Low Voltage ASIC Level Translation
- Mobile Phones, PDAs, Cameras

Important Information

- ESD Protection for All Pins
 - Human Body Model (HBM) > 6000 V
 - Machine Model (MM) > 400 V



ON Semiconductor®

<http://onsemi.com>

MARKING DIAGRAMS



UQFN8
MU SUFFIX
CASE 523AS



E = Specific Device Code
M = Date Code

LOGIC DIAGRAM

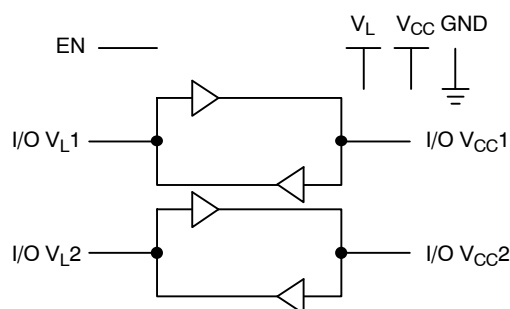

ORDERING INFORMATION

Device	Package	Shipping†
NLSX4302EBMUTCG	UQFN8 (Pb-Free)	3000/Tape & Reel

† For information on tape and reel specifications, including part orientation and tape sizes, please refer to our Tape and Reel Packaging Specification Brochure, BRD8011/D.

NLSX4302E

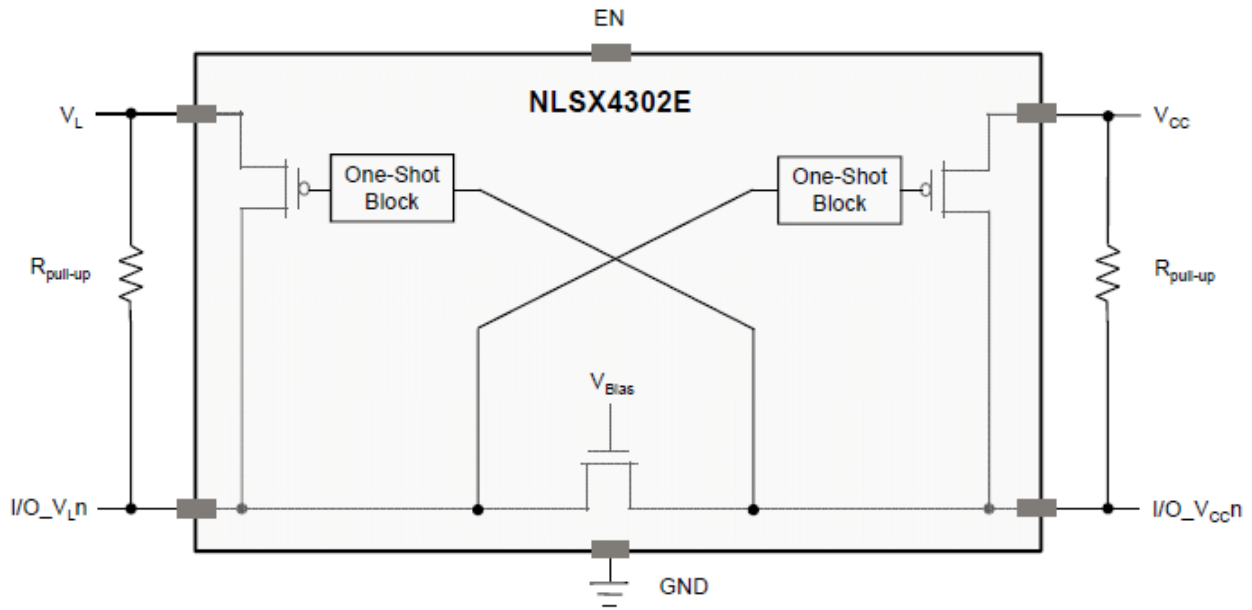

Figure 1. Block Diagram (1 I/O Line)

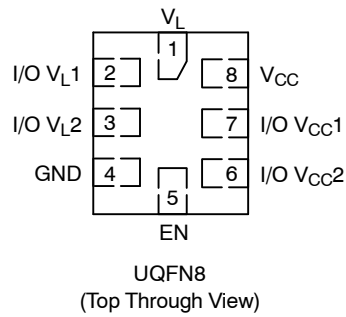

Figure 2. Pin-out Diagram

PIN ASSIGNMENT

Pins	Description
V _{CC}	V _{CC} Supply Voltage
V _L	V _L Supply Voltage
GND	Ground
EN	Output Enable, Referenced to V _L
I/O V _{CC} n	I/O Port, Referenced to V _{CC}
I/O V _L n	I/O Port, Referenced to V _L

FUNCTION TABLE

EN	Operating Mode
L	Hi-Z
H	I/O Buses Connected

NLSX4302E

MAXIMUM RATINGS

Symbol	Parameter	Value	Condition	Unit
V _{CC}	High-side DC Supply Voltage	-0.3 to +7.0		V
V _L	High-side DC Supply Voltage	-0.3 to +7.0		V
I/O V _{CC}	V _{CC} -Referenced DC Input/Output Voltage	-0.3 to (V _{CC} + 0.3)		V
I/O V _L	V _L -Referenced DC Input/Output Voltage	-0.3 to (V _L + 0.3)		V
V _{EN}	Enable Control Pin DC Input Voltage	-0.3 to +7.0		V
I _{I/O_SC}	Short-Circuit Duration (I/O V _L and I/O V _{CC} to GND)	40	Continuous	mA
T _{STG}	Storage Temperature	-65 to +150		°C

Stresses exceeding Maximum Ratings may damage the device. Maximum Ratings are stress ratings only. Functional operation above the Recommended Operating Conditions is not implied. Extended exposure to stresses above the Recommended Operating Conditions may affect device reliability.

RECOMMENDED OPERATING CONDITIONS

Symbol	Parameter	Min	Max	Unit
V _{CC}	High-side Positive DC Supply Voltage	1.5	5.5	V
V _L	High-side Positive DC Supply Voltage	1.5	5.5	V
V _{EN}	Enable Control Pin Voltage	GND	5.5	V
V _{IO_VCC}	I/O Pin Voltage (Side referred to V _{CC})	GND	V _{CC}	V
V _{IO_VL}	I/O Pin Voltage (Side referred to V _L)	GND	V _L	V
Δt/ΔV	Input Transition Rise and Fall Rate I/O V _L - or I/O V _L - Ports, Push-Pull Driving Control Input		10 10	ns/V
T _A	Operating Temperature Range	-40	+85	°C

NLSX4302E

DC ELECTRICAL CHARACTERISTICS ($V_L = 1.5\text{ V to }5.5\text{ V}$ and $V_{CC} = 1.5\text{ V to }5.5\text{ V}$, unless otherwise specified) (Note 1)

Symbol	Parameter	Test Conditions (Note 2)	V_L (V)	V_{CC} (V)	-40°C to +85°C			Unit		
					Min	Typ	Max			
V_{IH_VL}	I/O High Level I/O_VL	Data Inputs I/O_VL _n	1.65–5.50	1.65–5.50	$V_L - 0.4$			V		
		Control Input EN	1.65–5.50	1.65–5.50	$V_L \times 0.7$					
V_{IH_VCC}	I/O High Level I/O_VCC	Data Inputs I/O_VCC _n	1.65–5.50	1.65–5.50	$V_{CC} - 0.4$			V		
V_{IL_VL}	I/O Low Level I/O_VL	Data Inputs I/O_VL _n	1.65–5.50	1.65–5.50			0.4	V		
		Control Input EN	1.65–5.50	1.65–5.50			$V_L \times 0.3$			
V_{IL_VCC}	I/O Low Level I/O_VCC	Data Inputs I/O_VCC _n	1.65–5.50	1.65–5.50			0.4	V		
V_{OL}	Low Level Output Voltage	$V_{IL} = 0.15\text{ V}$, $I_{OL} = 6\text{ mA}$	1.65–5.50	1.65–5.50			0.4	V		
I_L	Input Leakage Current	Control Input EN, $V_{IN} = V_L$ or GND	1.65–5.50	1.65–5.50			± 1	μA		
I_{OFF}	Power-Off Leakage Current	I/O_VL _n , I/O_VCC _n	V_{IN} or $V_O = 0$ to 5.5 V	0	0			± 2	μA	
		I/O_VL _n		0	5.50					
		I/O_VCC _n		5.50	0					
I_{OZ}	Tristate Output Mode Leakage Current (Note 3)	I/O_VL _n , I/O_VCC _n	$V_O = 0$ to 5.5 V, EN = V_{IL}	5.50	5.50			± 2	μA	
		I/O_VL _n		$V_O = 0$ to 5.5 V, EN = Don't Care	5.50	0				
		I/O_VCC _n		$V_O = 0$ to 5.5 V, EN = Don't Care	0	5.50				
I_{CC}	Quiescent Supply Current, Active Mode (Notes 4, 5)	V_L	$V_{IN} = V_{CCI}$ or GND, $I_O = 0$, EN = V_{IH_VL}	1.65–5.50	1.65–5.50			5.0	μA	
		V_{CC}								
I_{CCZ}	Quiescent Supply Current, Standby Mode (Notes 4, 5)	V_L	$V_{IN} = V_{CCI}$ or GND, $I_O = 0$, EN = V_{IL_VL}	1.65–5.50	1.65–5.50			5.0	μA	
		V_{CC}								
I_{CC_OFF}	Quiescent Supply Current, Power-Off (Notes 3, 5)	V_L	$V_{IN} = 5.5\text{ V}$ or GND, $I_O = 0$, EN = Don't Care, I/O_VCC to I/O_VL	0	1.65–5.50			2.0	μA	
				1.65–5.50	0					
		V_{CC}	$V_{IN} = 5.5\text{ V}$ or GND, $I_O = 0$, EN = Don't Care, I/O_VL to I/O_VCC	1.65–5.50	0					
				0	1.65–5.50					

1. Typical values are for $V_L = +1.8\text{ V}$, $V_{CC} = +3.3\text{ V}$ and $T_A = +25^\circ\text{C}$.
2. All units are production tested at $T_A = +25^\circ\text{C}$. Limits over the operating temperature range are guaranteed by design.
3. "Don't care" indicates any valid logic level.
4. V_{CCI} is the power supply associated with the input side.
5. Reflects current per supply, V_L or V_{CC} .

NLSX4302E

DYNAMIC OUTPUT ELECTRICAL CHARACTERISTICS

OUTPUT RISE / FALL TIMES (Output Load: $C_L = 50$ pF, $R_{PU} = 2.2$ k Ω , push/pull driver, $T_A = -40^\circ\text{C}$ to $+85^\circ\text{C}$) (Note 6)

Symbol	Parameter	V_{CC0} (Note 7)				Unit
		4.5 to 5.5 V	3.0 to 3.6 V	2.3 to 2.7 V	1.65 to 1.95 V	
		Typ	Typ	Typ	Typ	
t_{RISE}	Output Rise Time, I/O_VL _n , I/O_VCC _n	6.4	5	6.5	10.7	ns
t_{FALL}	Output Fall Time, I/O_VL _n , I/O_VCC _n	10	9.5	8.6	9.5	ns

6. Output rise and fall times guaranteed by design and are not production tested.

7. V_{CC0} is the V_L or V_{CC} power supply associated with the output side.

MAXIMUM DATA RATE (Output Load: $C_L = 50$ pF, $R_{PU} = 2.2$ k Ω , push/pull driver, $T_A = -40^\circ\text{C}$ to $+85^\circ\text{C}$) (Note 8)

V_L	Parameter	V_{CC}				Unit
		4.5 to 5.5 V	3.0 to 3.6 V	2.3 to 2.7 V	1.65 to 1.95 V	
		Min	Min	Min	Min	
4.5 to 5.5 V	I/O_VL _n to I/O_VCC _n or I/O_VCC _n to I/O_VL _n	50	41	31	17	MHz
3.0 to 3.6 V		34	35	36	23	MHz
2.3 to 2.7 V		25	27	30	24	MHz
1.65 to 1.95 V		14	16	22	21	MHz

8. Maximum frequency guaranteed by design and is not production tested.

NLSX4302E

AC ELECTRICAL CHARACTERISTICS (Output Load: $C_L = 50$ pF, $R_{PU} = 2.2$ k Ω , push/pull driver, $T_A = -40^\circ\text{C}$ to $+85^\circ\text{C}$) (Note 9)

Symbol	Parameter	V _{CC}								Unit
		4.5 to 5.5 V		3.0 to 3.6 V		2.3 to 2.7 V		1.65 to 1.95 V		
		Typ	Max	Typ	Max	Typ	Max	Typ	Max	

V_L = 4.5 to 5.5 V

t _{PLH}	I/O_VL _n to I/O_VCC _n , I/O_VCC _n to I/O_VL _n	2.5	4.3	3	5	3	6.4	4	8.6	ns
t _{PHL}	I/O_VL _n to I/O_VCC _n , I/O_VCC _n to I/O_VL _n	5	8.1	8	13	8	17.3	15	28.5	ns
t _{PZL}	OE to I/O_VI _n , OE to I/O_VCC _n	14	19.6	16	20	22	26.5	33	44	ns
t _{PLZ}	OE to I/O_VI _n , OE to I/O_VCC _n	24	31.4	25	32	24	31.8	28	36.2	ns
t _{skew}	I/O_VL _n to I/O_VCC _n , I/O_VCC _n to I/O_VL _n (Note 10)	0.3	0.3	0.5	0.6	0.8	0.8	1.2	1.9	ns

V_L = 3.0 to 3.6 V

t _{PLH}	I/O_VL _n to I/O_VCC _n , I/O_VCC _n to I/O_VL _n	2.5	4.7	3	5.4	3	6.5	5	9.3	ns
t _{PHL}	I/O_VL _n to I/O_VCC _n , I/O_VCC _n to I/O_VL _n	7	14.2	6	10.1	8	14.6	15	27	ns
t _{PZL}	OE to I/O_VI _n , OE to I/O_VCC _n	15	18.8	18	22.3	19	23.5	29	38.3	ns
t _{PLZ}	OE to I/O_VI _n , OE to I/O_VCC _n	25	34.9	22	27.6	22	27.9	23	28.8	ns
t _{skew}	I/O_VL _n to I/O_VCC _n , I/O_VCC _n to I/O_VL _n (Note 10)	0.4	0.5	0.5	0.6	0.6	0.7	2.5	3.0	ns

V_L = 2.3 to 2.7 V

t _{PLH}	I/O_VL _n to I/O_VCC _n , I/O_VCC _n to I/O_VL _n	3	5.6	4	6	4	7.3	6	10.3	ns
t _{PHL}	I/O_VL _n to I/O_VCC _n , I/O_VCC _n to I/O_VL _n	12	18.1	11	14.1	8	11.9	15	22.1	ns
t _{PZL}	OE to I/O_VI _n , OE to I/O_VCC _n	16	23.7	17	21.5	25	30	31	36.6	ns
t _{PLZ}	OE to I/O_VI _n , OE to I/O_VCC _n	28	33.8	26	31	25	30.8	25	30	ns
t _{skew}	I/O_VL _n to I/O_VCC _n , I/O_VCC _n to I/O_VL _n (Note 10)	0.5	0.7	0.8	1	0.6	0.6	2.3	2.7	ns

V_L = 1.65 to 1.95 V

t _{PLH}	I/O_VL _n to I/O_VCC _n , I/O_VCC _n to I/O_VL _n	5	9	5	9.2	6	9.2	7	12.7	ns
t _{PHL}	I/O_VL _n to I/O_VCC _n , I/O_VCC _n to I/O_VL _n	19	28.3	15	25.5	12	17.3	14	19	ns
t _{PZL}	OE to I/O_VI _n , OE to I/O_VCC _n	23	32.2	22	26.5	25	32	40	72	ns
t _{PLZ}	OE to I/O_VI _n , OE to I/O_VCC _n	35	44	32	38.7	33	36.7	30	36.5	ns
t _{skew}	I/O_VL _n to I/O_VCC _n , I/O_VCC _n to I/O_VL _n (Note 10)	0.5	1.1	1.4	1.5	0.8	1.1	2.0	2.5	ns

9. AC characteristics are guaranteed by design and are not production tested.

10. Skew is the variation of propagation delay between output signals and applies only to output signals on the same port (I/O_VL_n or I/O_VCC_n) and switching with the same polarity (LOW-to-HIGH or HIGH-to-LOW). Skew is defined by applying a single input to the two input channels and measuring the difference in propagation delays between the output channels.

NLSX4302E

CAPACITANCE ($T_A = 25^\circ\text{C}$)

Symbol	Parameter	Test Condition	Typical	Unit
C_{IN}	Input Capacitance, Control Pin (EN)	$V_L = V_{CC} = \text{GND}$	2	pF
C_{IO}	Input / Output Capacitance (I/O_VL_n , I/O_VCC_n)	$V_L = V_{CC} = 5\text{ V}, \text{EN} = \text{GND}, I/O_VL_n = I/O_VCC_n = 5\text{ V}$	3	pF
C_{PD}	Power Dissipation Capacitance (Note 11)	$V_L = V_{CC} = 5\text{ V}, \text{EN} = 5\text{ V}, V_{IN} = 5\text{ V or GND}, f = 400\text{ KHz}$	17	pF

11. C_{PD} is defined as the value of the internal equivalent capacitance per channel.

TEST SETUP AND TIMING DEFINITIONS

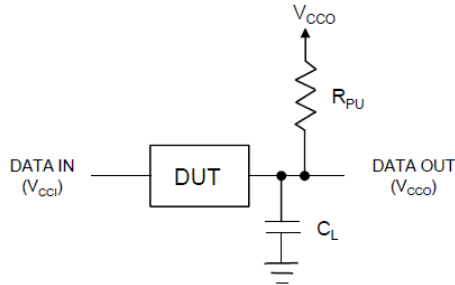

Figure 3. AC Test Circuit

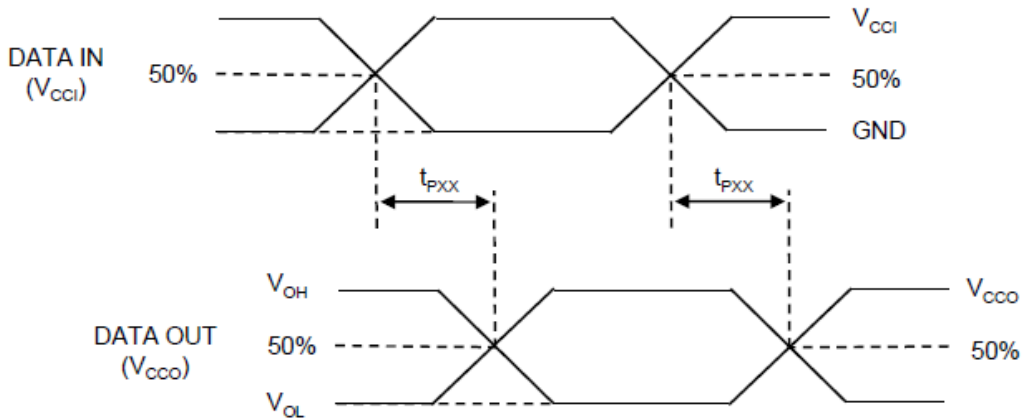

Figure 4. Propagation Delays and Tri-State Measurements

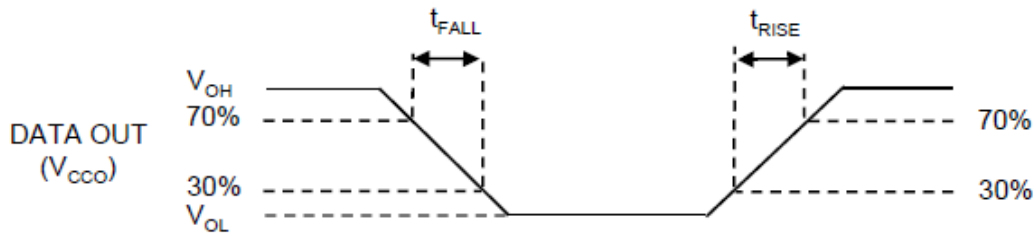

Figure 5. Definition of Rise and Fall Times

NLSX4302E

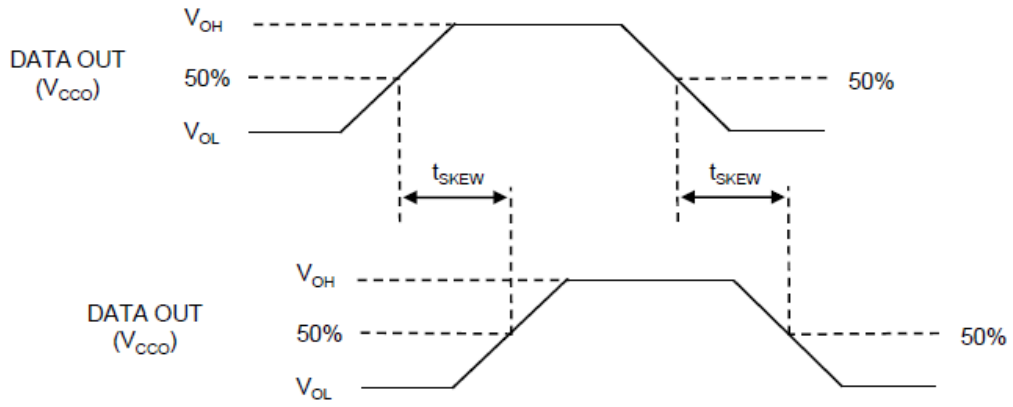

Figure 6. Definition of Output Skew

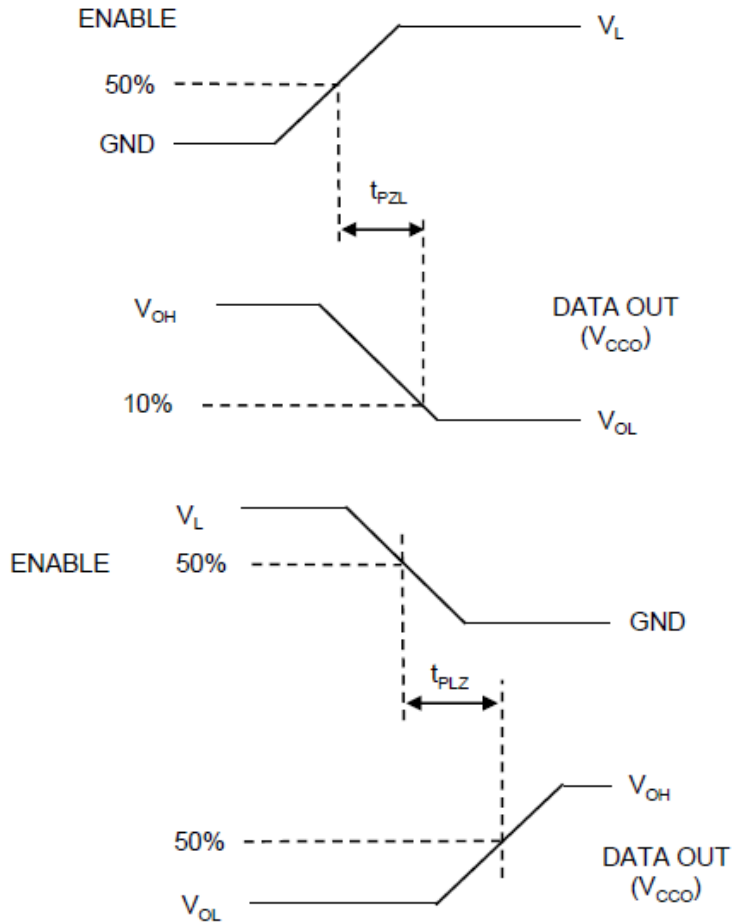

Figure 7. Definition of Output Tri-State Times

APPLICATIONS INFORMATION

Level Translator Architecture

The NLSX4302E auto sense translator provides bi-directional voltage level shifting to transfer data in multiple supply voltage systems. This device has two supply voltages, V_L and V_{CC} , which set the logic levels on the input and output sides of the translator. When used to transfer data from the V_L to the V_{CC} ports, input signals referenced to the V_L supply are translated to output signals with a logic level matched to V_{CC} . In a similar manner, the V_{CC} to V_L translation shifts input signals with a logic level compatible to V_{CC} to an output signal matched to V_L .

The NLSX4302E consists of two bi-directional channels that independently determine the direction of the data flow without requiring a directional pin. The one-shot circuits are used to detect the rising or falling input signals. In addition, the one shots decrease the rise and fall time of the output signal for high-to-low and low-to-high transitions. Each input/output channel requires external pullup resistors.

Enable Input (EN)

The NLSX4302E has an Enable pin (EN) that can be used to minimize the power consumption of the device

when the transmitter is not transmitting data. Normal translation operation occurs when the EN pin is equal to a logic high signal. The EN pin is referenced to the V_L supply and has Overvoltage Tolerant (OVT) protection.

Power Supply Guidelines

The sequencing of the power supplies will not damage the device during the power up operation. In addition, the I/O V_{CC} and I/O V_L pins are in the high impedance state if either supply voltage is equal to 0 V. For optimal performance, 0.01 μ F to 0.1 μ F decoupling capacitors should be used on the V_L and V_{CC} power supply pins. Ceramic capacitors are a good design choice to filter and bypass any noise signals on the voltage lines to the ground plane of the PCB. The noise immunity will be maximized by placing the capacitors as close as possible to the supply and ground pins, along with minimizing the PCB connection traces.

MECHANICAL CASE OUTLINE

PACKAGE DIMENSIONS

ON Semiconductor®



SCALE 4:1

UQFN8, 1.4x1.2, 0.4P
CASE 523AS
ISSUE A

DATE 20 JAN 2012

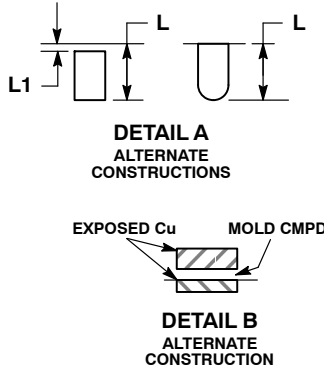
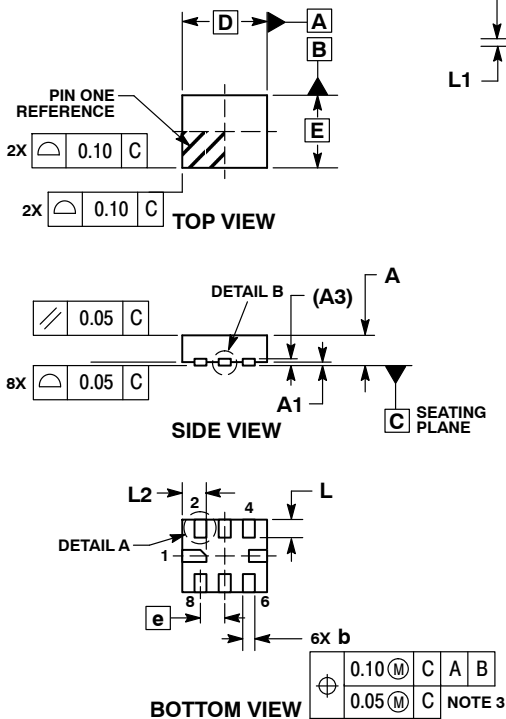

NOTES:

1. DIMENSIONING AND TOLERANCING PER ASME Y14.5M, 1994.
2. CONTROLLING DIMENSION: MILLIMETERS.
3. DIMENSION b APPLIES TO PLATED TERMINAL AND IS MEASURED BETWEEN 0.15 AND 0.25 mm FROM THE TERMINAL TIP.

DIM	MILLIMETERS	
	MIN	MAX
A	0.45	0.55
A1	0.00	0.05
A3	0.13	REF
b	0.15	0.25
D	1.40 BSC	
E	1.20 BSC	
e	0.40 BSC	
L	0.20	0.40
L1	---	0.15
L2	0.30	0.50

GENERIC MARKING DIAGRAM*



X = Specific Device Code
M = Date Code

*This information is generic. Please refer to device data sheet for actual part marking.
Pb-Free indicator, "G" or microdot "▪", may or may not be present.

SOLDERING FOOTPRINT*

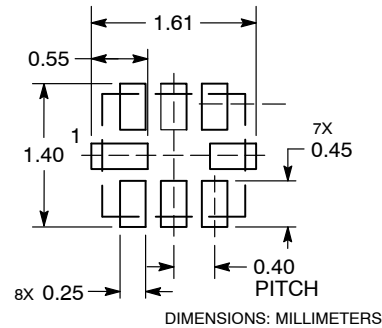

*For additional information on our Pb-Free strategy and soldering details, please download the ON Semiconductor Soldering and Mounting Techniques Reference Manual, SOLDERRM/D.

DOCUMENT NUMBER:	98AON58906E	Electronic versions are uncontrolled except when accessed directly from the Document Repository. Printed versions are uncontrolled except when stamped "CONTROLLED COPY" in red.
DESCRIPTION:	UQFN8, 1.4X1.2, 0.4P	PAGE 1 OF 1

ON Semiconductor and are trademarks of Semiconductor Components Industries, LLC dba ON Semiconductor or its subsidiaries in the United States and/or other countries. ON Semiconductor reserves the right to make changes without further notice to any products herein. ON Semiconductor makes no warranty, representation or guarantee regarding the suitability of its products for any particular purpose, nor does ON Semiconductor assume any liability arising out of the application or use of any product or circuit, and specifically disclaims any and all liability, including without limitation special, consequential or incidental damages. ON Semiconductor does not convey any license under its patent rights nor the rights of others.

ON Semiconductor and  are trademarks of Semiconductor Components Industries, LLC dba ON Semiconductor or its subsidiaries in the United States and/or other countries. ON Semiconductor owns the rights to a number of patents, trademarks, copyrights, trade secrets, and other intellectual property. A listing of ON Semiconductor's product/patent coverage may be accessed at www.onsemi.com/site/pdf/Patent-Marking.pdf. ON Semiconductor reserves the right to make changes without further notice to any products herein. ON Semiconductor makes no warranty, representation or guarantee regarding the suitability of its products for any particular purpose, nor does ON Semiconductor assume any liability arising out of the application or use of any product or circuit, and specifically disclaims any and all liability, including without limitation special, consequential or incidental damages. Buyer is responsible for its products and applications using ON Semiconductor products, including compliance with all laws, regulations and safety requirements or standards, regardless of any support or applications information provided by ON Semiconductor. "Typical" parameters which may be provided in ON Semiconductor data sheets and/or specifications can and do vary in different applications and actual performance may vary over time. All operating parameters, including "Typicals" must be validated for each customer application by customer's technical experts. ON Semiconductor does not convey any license under its patent rights nor the rights of others. ON Semiconductor products are not designed, intended, or authorized for use as a critical component in life support systems or any FDA Class 3 medical devices or medical devices with a same or similar classification in a foreign jurisdiction or any devices intended for implantation in the human body. Should Buyer purchase or use ON Semiconductor products for any such unintended or unauthorized application, Buyer shall indemnify and hold ON Semiconductor and its officers, employees, subsidiaries, affiliates, and distributors harmless against all claims, costs, damages, and expenses, and reasonable attorney fees arising out of, directly or indirectly, any claim of personal injury or death associated with such unintended or unauthorized use, even if such claim alleges that ON Semiconductor was negligent regarding the design or manufacture of the part. ON Semiconductor is an Equal Opportunity/Affirmative Action Employer. This literature is subject to all applicable copyright laws and is not for resale in any manner.

PUBLICATION ORDERING INFORMATION

LITERATURE FULFILLMENT:

Email Requests to: orderlit@onsemi.com

ON Semiconductor Website: www.onsemi.com

TECHNICAL SUPPORT

North American Technical Support:
Voice Mail: 1 800-282-9855 Toll Free USA/Canada
Phone: 011 421 33 790 2910

Europe, Middle East and Africa Technical Support:

Phone: 00421 33 790 2910

For additional information, please contact your local Sales Representative