

SEE TABLE

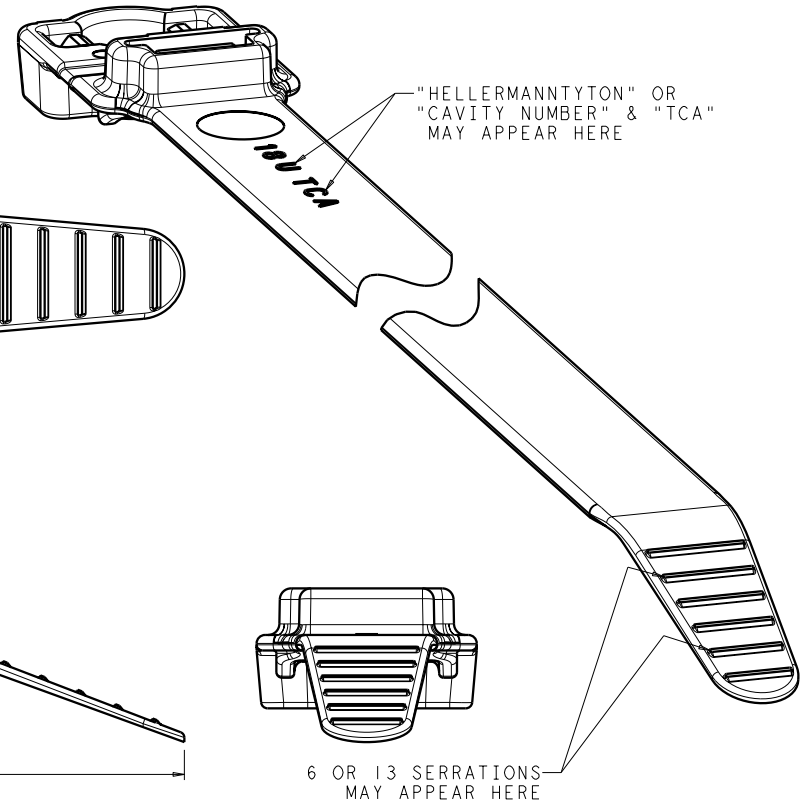
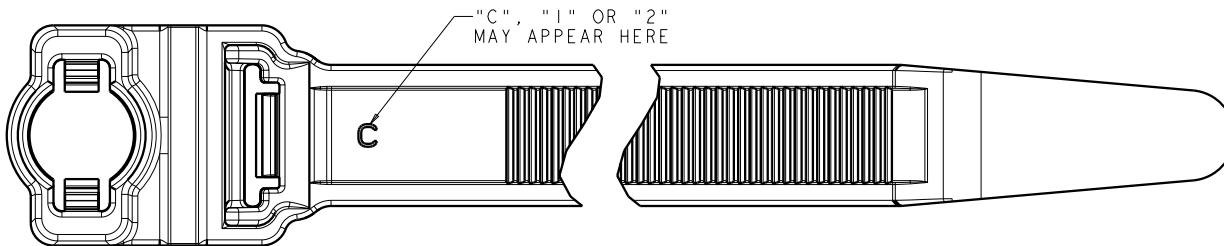

- △04 PERFORMANCE REQUIREMENTS (Dry as Molded):**
1. STRAP INSERTION < 5 lb.
  2. MINIMUM WIRE BUNDLE DIAMETER = 3/8"
  3. LOOP TENSILE > 120 lb.
  4. STUD INSERTION < 10 lb.
  5. STUD PULLOUT > 110 lb.

PART NUMBER	OVERALL LENGTH	MAX BUNDLE DIA
WSS380	9.7	2.25
WSI380	12.7	3.25
WSR380	15.7	4.125

INVENTORS

**HellermannTyton®**

ALL PROPRIETARY RIGHTS IN THE SUBJECT MATTER SHOWN ON THIS DRAWING ARE EXCLUSIVE PROPERTY OF HELLERMANN TYTON

name	date	city, state
G GEIGER	3/17/03	JACKSON, WI

REVISION

D level	△04
by	GGG
date	11/25/09
ECN #	011439
part level	B

DIMENSIONS

TOLERANCES UNLESS OTHERWISE SPECIFIED	units inches/[mm]
.XXXX= ±0.005/[.127]	
.XXX= ±0.010/[.25]	
.XX= ±0.02/[.5]	
.X= ±0.25/[6.4]	
∠= ±0.5	

PART

number	see table	phase	△04 PRODUCTION
name	T120 WIDE STRAP W/ 3/8" STUD MOUNT		
material	IMPACT MODIFIED, HEAT STABILIZED UV RESISTANT, NYLON 6/6 BLACK		

DRAWING

FORMAT	AH version	J	CAD	PRO-E	scale	3/2
computer file number			previous number			
drawn	G GEIGER	checked	K Christian	approved		
date	8/29/02	checked	11/25/09	approved		
type	CUSTOMER				sheet	1 of 1
number	CT2127010CST					