

-	-	-	-	0,5 to 3	>3 to 6	>6 to 30	>30 to 120	DRAWN / GEZEICHNET Moy	DATE / DATUM 21.01.21	DIMS / EINHEIT MM	MATERIAL -	WEIGHT [g] / GEWICHT [g] 310.81	D. SIZE / FORMAT A3
-	-	-	-	±0,1	±0,1	±0,2	±0,3	APPD / GEPRÜFT Schwinn	DATE / DATUM 01.06.21	SCALE / MAßSTAB 1:1	TITLE EVOcut cpl.		
				TOLERANCES/TOLERANZEN ISO 2768-m				HELLERMANNTYTON			BENENNUNG EVOcut kpl.		
				THE COPYRIGHT OF THIS DRAWING IS RESERVED BY HELLERMANNTYTON GMBH. IT IS ISSUED ON CONDITION THAT IT IS NOT REPRODUCED, COPIED, OR DISCLOSED TO A THIRD PARTY, EITHER WHOLLY OR IN PART, WITHOUT THE CONSENT OF HELLERMANNTYTON GMBH.				DAS URHEBERRECHT DIESER ZEICHNUNG LIEGT BEI HELLERMANNTYTON GMBH. DIE ZEICHNUNG DARF OHNE ZUSTIMMUNG VON HELLERMANNTYTON GMBH WEDER KOPERT, VERVIELFÄLTIGT ODER DRITTEN ZUGÄNGLICH GEMACHT WERDEN.			HELLERMANNTYTON GMBH GROßER MOORWEG 45, 25436 TÖRNESCH PHONE: +49 4122 701 274, Fax: +49 41 22 701 215		
01	Page and views added	22.01.2021	Moy					HELLERMANNTYTON			UNGS 110-05005	INDEX 3	PAGE 1/2 SEITE 1/2
NO. / NR.	DESCRIPTION / BESCHREIBUNG	DATE / DATUM	NAME								DRAWING NO. / ZEICHNUNGSNUMMER 18-1366-960-CON		

PARTS LIST / STÜCKLISTE 110-05005 / EVOcut kpl.

POS.	UNS	TITLE / BENENNUNG	Material	PC. / STK.
1	110-05060	Etikett Links	PVC-U	1
2	110-05062	Gehäuse Links	PA66_30GF	1
3	110-05065	Rückstellfeder	1_4310	1
4	110-05068	Messer Fertigteil	1_2842	2
5	110-05069	Handhabel kpl.	-	1
6	110-05070	Gehäuse Rechts kpl.	-	1
7	110-05090	Stirnkappe klein	PA66_30GF	1
8	110-05091	Stirnkappe mittel	PA66_30GF	1
9	110-05092	Stirnkappe groß	PA66_30GF	1
10	110-70015	Trigger Boot 80mm span	PUR	1
11	110-70024	SHORT LINK ATTACHMENT PIN	1_2842	1
12	123-10149	EJOLT_Delta_PT_WM_5421_25x12-STIE	4310	4
13	123-13054	DIN 6325 - ISO 8734 - 4x18	1_2067	1
14	123-13055	DIN 7 - ISO 2338 - 5x16	1_4305	1

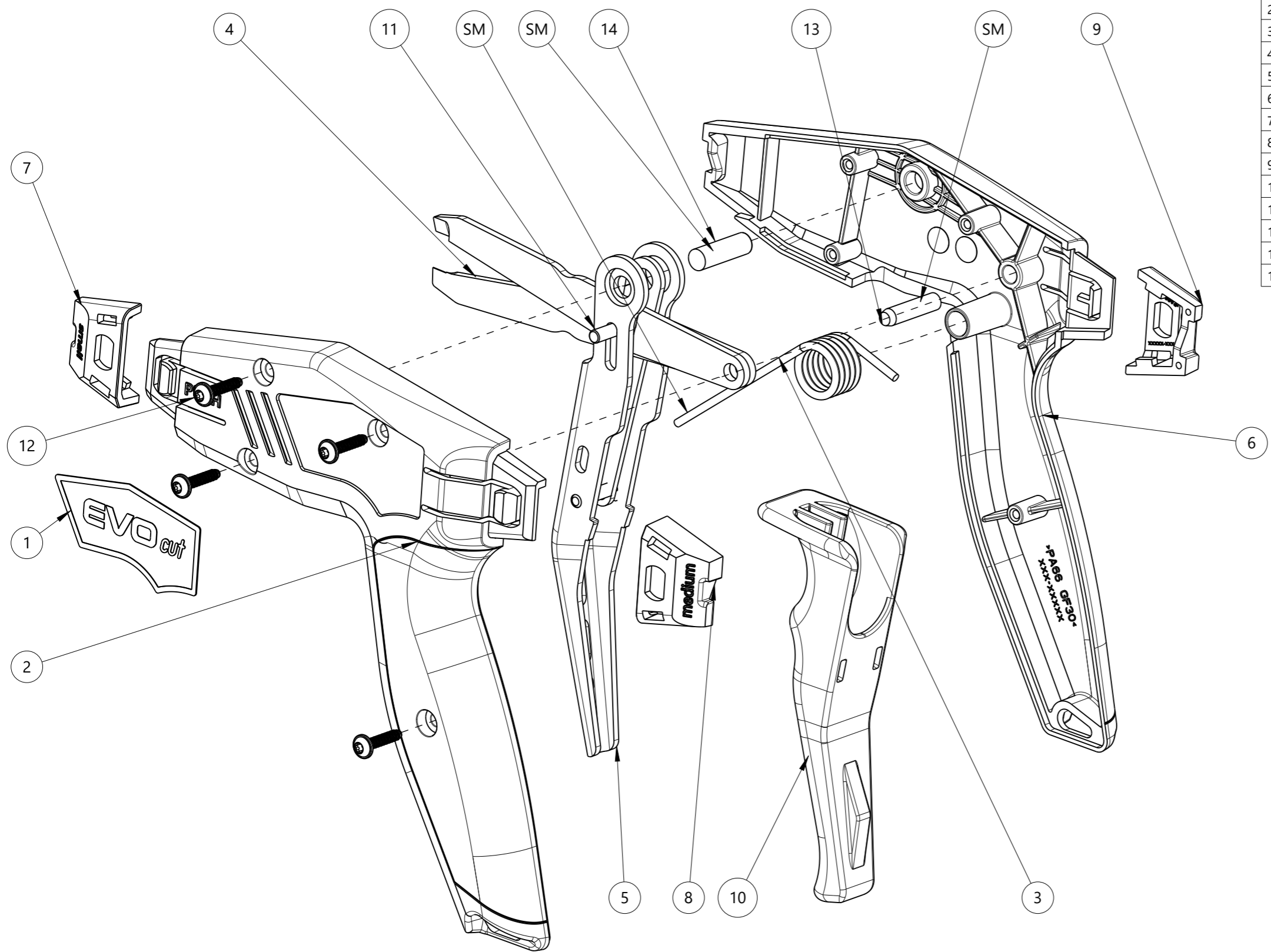

Messer einlegen

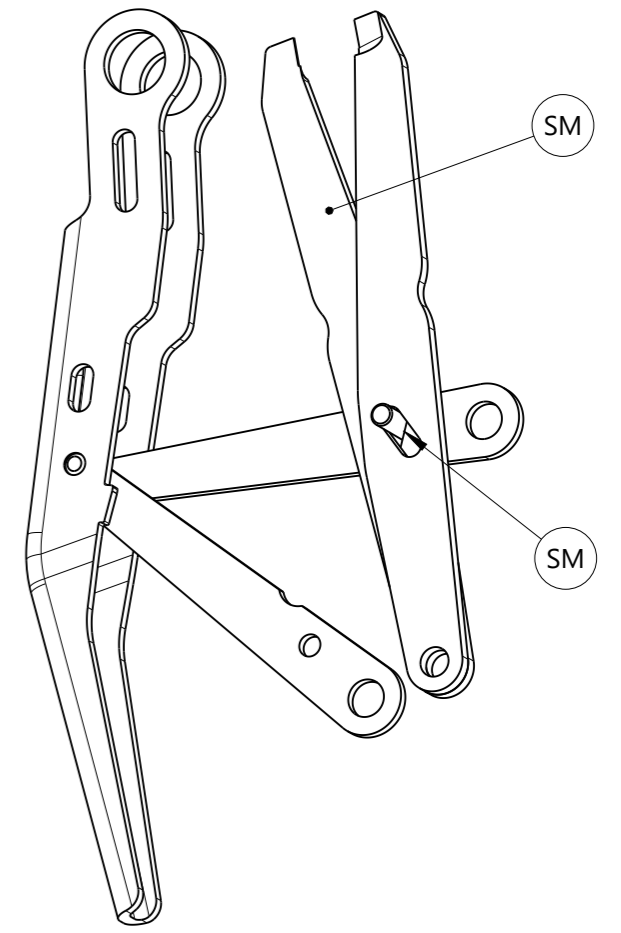

SM: Schmiermittel "Fuchs Renolit MP" auftragen

-	-	-	-	0,5 to 3	>3 to 6	>6 to 30	>30 to 120	DRAWN / GEZEICHNET Moy	DATE / DATUM 04.07.19	DIMS / EINHEIT MM	MATERIAL -	WEIGHT [g] / GEWICHT [g] 310.81	D. SIZE / FORMAT A3	
-	-	-	-	±0,1	±0,1	±0,2	±0,3	APPD / GEPRÜFT Schwinn	DATE / DATUM 01.06.21	SCALE / MAßSTAB 1:1	TITLE EVOcut cpl.			
TOLERANCES/TOLERANZEN ISO 2768-m								HELLERMANN TYTON GMBH GROßER MOORWEG 45, 25436 TORNESCH PHONE: +49 4122 701 274, Fax: +49 41 22 701 215		BENENNUNG EVOcut kpl.			INDEX 3	PAGE 2/2 SEITE 2/2
03	Montagebaugruppen erzeugt	14.06.2022	Moy	THE COPYRIGHT OF THIS DRAWING IS RESERVED BY HELLERMANN TYTON GMBH. IT IS ISSUED ON CONDITION THAT IT IS NOT REPRODUCED, COPIED, OR DISCLOSED TO A THIRD PARTY, EITHER WHOLLY OR IN PART, WITHOUT THE CONSENT OF HELLERMANN TYTON GMBH.				HELLERMANN TYTON GMBH GROßER MOORWEG 45, 25436 TORNESCH PHONE: +49 4122 701 274, Fax: +49 41 22 701 215		UNITS 110-05005			DRAWING NO / ZEICHNUNGSNUMMER 18-1366-960-CON	
02	Pos. 7 gegen UNS 110-05068 ausget.	26.05.2021	Moy											
NO. / NR.	DESCRIPTION / BESCHREIBUNG	DATE / DATUM	NAME											