

# Q45UPSD Universal Pressure Monitoring Node

## Datasheet

The Wireless Q45UPSD Universal Pressure Monitoring Node and cabled transducer accessories combine a media isolated pressure sensor with reliable, field proven, Sure Cross<sup>®</sup> wireless architecture into one packaged solution. This solution monitors pressurized systems in remote locations without human intervention. The industrial-grade, battery-powered device can wirelessly transmit pressure levels to a wireless controller/gateway for remote monitoring of critical systems.

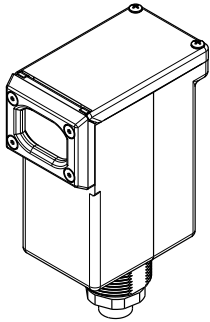

### Benefits

- Provides for the ability to deliver factory automation and IIoT solutions for many applications including, but not limited to monitoring:
  - Water pressure
  - HVAC systems
  - Pneumatic systems
  - Cooling systems/compressors/chillers
  - Hydraulic system pressure
  - Supply tank level via the head pressure
- **Eliminate control wires**—The Sure Cross wireless system is a radio frequency network with integrated I/O that removes the need for power and control wires
- **Reduce complexity**—Machine or process reconfiguration made easier; great for retrofit applications
- **Deploy easily**—Simplify installation on existing equipment to enable deployment in remote and hard-to-access locations where implementing a wired solution would be difficult, impractical, or not cost-effective
- Connect the Q45UPSD to any cabled pressure transducer accessory for easy deployment in a variety of applications
- Integral quick disconnect connection allows for easy replacement of the cabled pressure transducer
- Selectable transmit power levels of 250 mW or 1 Watt for 900 MHz models
- DIP switches for user configuration
- Frequency Hopping Spread Spectrum (FHSS) technology ensures reliable data delivery
- Transceivers provide bidirectional communication between the Gateway and Node, including fully acknowledged data transmission
- Diagnostics allow user defined output settings in the unlikely event of lost RF signal

## Q45UPSD Models

Q45 Node Models	Radio Frequency	Inputs and Outputs
DX80N9Q45UPSD	900 MHz ISM Band	One 0-10 V Analog input for use with any <b>BWA-PRESSURE-SENSOR</b> sensor product
DX80N2Q45UPSD	2.4 GHz ISM Band	

To order a model without the battery, add **NB** to the model number. For example, **DX80N9Q45UPSD NB**.

Model	Measurement Range	Description	Connection
<b>BWA-PRESSURE-SENSOR-50</b>	0–50 PSI	Includes pressure sensor PS1G50; gauge; 1/4"-18 NPT port	1 meter (39.36") cable with a 4-pin M12 male quick disconnect connector
<b>BWA-PRESSURE-SENSOR-150</b>	0–150 PSI	Includes pressure sensor PS1G150; gauge; 1/4"-18 NPT port	
<b>BWA-PRESSURE-SENSOR-500</b>	0–500 PSI	Includes pressure sensor PS1S500; sealed gauge; 1/4"-18 NPT port	
<b>BWA-PRESSURE-SENSOR-3000</b>	0–3000 PSI	Includes pressure sensor PS1S3000; sealed gauge; 1/4"-18 NPT port	

## Storage Mode

While in **storage mode**, the device's radio does not operate, to conserve the battery. To put any device into storage mode, press and hold the binding button for five seconds. The device is in storage mode when the LEDs stop blinking. To wake the device, press and hold the binding button (inside the housing on the radio board) for five seconds.

# Configuration Instructions

## Button and LEDs

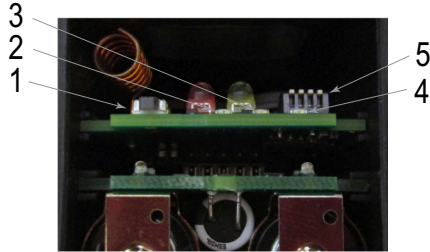

- 1 Binding button
- 2 Red LED (flashing) indicates a radio link error with the Gateway.
- 3 Green LED (flashing) indicates a good radio link with the Gateway.
- 4 Amber LED is not used.
- 5 DIP switches

## DIP Switches

After making any changes to any DIP switch position, reboot the Q45 by triple-clicking the button, waiting a second, then double-clicking the button.

The DIP switches are in the OFF position. To turn a DIP switch on, push the switch toward the battery pack. DIP switches are numbered from left to right. The factory default sample and report rate is 5 minutes.

	DIP Switches							
	1	2	3	4	5	6	7	8
900 MHz transmit power level: 1 Watt (30 dBm)	OFF *							
900 MHz transmit power level: 250 mW (24 dBm), DX80 compatibility mode	ON							
Temperature in Fahrenheit		OFF *						
Temperature in Celsius		ON						
Reserved			OFF *					
Reserved				OFF *				
Reserved					OFF *			
Modbus or software configured (overrides DIP switches)						OFF *	OFF *	OFF *
Sample/report rate of 15 minutes						OFF	OFF	ON
Sample/report rate of 5 minutes						OFF	ON	OFF
Sample/report rate of 64 seconds						OFF	ON	ON
Sample/report rate of 16 seconds						ON	OFF	OFF
Sample/report rate of 4 seconds						ON	OFF	ON
Sample/report rate of 2 seconds						ON	ON	OFF
Sample/report rate of 1 seconds						ON	ON	ON

## Transmit Power Levels

The 900 MHz radios transmit at 1 Watt (30 dBm) or 250 mW (24 dBm). The 250 mW mode reduces the radio's range but improves the battery life in short range applications. For 2.4 GHz models, this DIP switch is disabled. The transmit power for 2.4 GHz is fixed at about 65 mW EIRP (18 dBm).

## Sample and Report Rates

The sample interval, or rate, defines how often the Sure Cross device samples the input. For battery-powered applications, setting a slower rate extends the battery life.

The report rate defines how often the Node communicates the I/O status to the Gateway. For battery-powered applications, setting the report rate to a slower rate extends the battery life.

## What is Sampling on Demand?

Sample on demand allows a host system to send a Modbus command to a register and require the inputs to immediately sample the sensor and report readings back to the host system and/or Gateway. Sampling on demand can be used between the normal periodic reporting.

The sample on demand feature requires using a host-controlled system capable of sending Modbus commands to the primary radio.

## Sample an Input Using a Host System

To sample the input, have the Host System write to the Node's register 15. To calculate which register this is for your Node, use this equation:  $15 + (\text{Node \#} \times 16)$ .

1. From the host system, write 0x13xx to the Node's register 15, where xx defines the input you want to sample.

For Input	Write Value (in hex)	Write Value (in decimal)
1	0x1301	4865
2	0x1302	4866
3	0x1304	4868
4	0x1308	4872
5	0x1310	4880
6	0x1320	4896
All Inputs	0x133F	4927

2. To send the Sample on Demand command to more than one input, add together the binary representation values. For example, to demand a sampling of inputs 1, 2, and 3, the Hex command is 0x1307.

## Apply Power to the Q45 D-Cell Models

Follow these instructions to install or replace the lithium D-cell batteries.

CONTEXT:



As with all batteries, these are fire, explosion, and severe burn hazards. Do not burn or expose them to high temperatures. Do not recharge, crush, disassemble, or expose the contents to water. Properly dispose of used batteries according to local regulations by taking them to a hazardous waste collection site, an e-waste disposal center, or another facility qualified to accept lithium batteries.



1. Loosen the clamp plate with a small Phillips screwdriver and lift the cover.
2. Use the black pull wire to pull the battery board out of the Q45 housing.
3. If applicable, remove the discharged battery.
4. Install the new battery. Use Banner's **BWA-BATT-011** replacement battery or an equivalent 3.6 V D-cell lithium battery, such as Xeno's XL-205F.
5. Verify the battery's positive and negative terminals align to the positive and negative terminals of the battery holder mounted within the case. Caution: There is a risk of explosion if the battery is replaced incorrectly.
6. Slide the board containing the new battery back into the Q45 housing.
7. Close the cover and gently tighten the clamp plate with the small Phillips screwdriver.

## Bind to the Gateway and Assign the Node Address

**PREREQUISITE:**

Before beginning the binding procedure, apply power to all the devices. Separate the devices by two meters when running binding procedure. Put only one Gateway into binding at a time to prevent binding to the wrong Gateway.

1. On the Gateway: Enter binding mode.
  - For housed DX80 Gateways, triple-click button 2 on the Gateway. Both LEDs flash red.
  - For Gateway board modules, triple-click the button. The green and red LED flashes.
2. Assign the Q45UPSD a Node address using the Gateway's rotary dials. Use the left rotary dial for the left digit and the right rotary dial for the right digit. For example, to assign your Q45UPSD to Node 10, set the Gateway's left dial to 1 and the right dial to 0. Valid Node addresses are 01 through 47.



3. On the Q45: Loosen the clamp plate on the top of the Q45UPSD and lift the cover.
4. Enter binding mode on the Q45UPSD by triple-clicking the Q45UPSD's button.  
 STEP RESULT: The red and green LEDs flash alternately and the sensor searches for a Gateway in binding mode. After the Q45UPSD is bound, the LEDs stay solid momentarily, then they flash together four times. The Q45UPSD exits binding mode.
5. Label the sensor with the Q45UPSD's Node address number for future reference.
6. Repeat steps 2 through 5 for as many Q45UPSDs as are needed for your network.
7. On the Gateway: After binding all Q45UPSDs, exit binding mode.
  - For housed DX80 Gateways, double-click button 2.
  - For board-level DX80 Gateways, double-click the button.

**AFTER COMPLETING THIS TASK:**

For Gateways with single-line LCDs: After binding your Q45UPSD to the Gateway, make note of the binding code displayed under the Gateway's \*DVCFG menu, XADR submenu on the LCD. Knowing the binding code prevents having to re-bind all Q45UPSDs if your Gateway is ever replaced.

## Bind to a DXM and Assign the Node Address

**PREREQUISITE:**

Before beginning the binding procedure, apply power to all the devices. Separate the radios by two meters when running the binding procedure. Put only one DXM into binding mode at a time to prevent the Q45UPSD from binding to the wrong Gateway.

1. On the DXM: Use the arrow keys to select the **ISM Radio** menu on the LCD and click **ENTER**.
2. Highlight the **Binding** menu and click **ENTER**.
3. Use the arrow keys to select the Node address to bind the Q45UPSD to.
4. On the Q45UPSD: Loosen the top clamp plate and lift the cover.
5. Enter binding mode by triple-clicking the binding button.  
 STEP RESULT: The red and green LEDs flash alternately and the sensor searches for a Gateway in binding mode. After the Node binds, the LEDs stay solid momentarily, then they flash together four times. The Node exits binding mode.
6. Label the sensor with the Node address number for future reference.
7. On the DXM: Click **BACK** to exit binding for that specific Node address.
8. Repeat steps 3 through 7 and change the Node address for as many Q45UPSDs as are needed for your network.
9. On the DXM: After you have finished forming your network, click **BACK** until you reach the main menu.

## Modbus Registers

**Table 1:** Modbus holding registers (Sheet 1 of 2)

I/O #	Modbus Holding Register		I/O Type	I/O Range		Holding Register Representation	
	Gateway	Any Node		Minimum	Maximum	Minimum	Maximum
1	1	1 + (Node# × 16)	Temperature	-1638.3	1638.4	-32768	32767
2	2	2 + (Node# × 16)	Pressure (unscaled)	0	65535	0	65535
		...					
7	7	7 + (Node# × 16)	Reserved				

**Table 1:** Modbus holding registers (Continued) (Sheet 2 of 2)

I/O #	Modbus Holding Register		I/O Type	I/O Range		Holding Register Representation	
	Gateway	Any Node		Minimum	Maximum	Minimum	Maximum
8	8	8 + (Node# × 16)	Device Message				
		...					
15	15	15 + (Node# × 16)	Control Message				
16	16	16 + (Node# × 16)	Reserved				

For temperature values: Temperature = (Modbus register value) ÷ 20.

The Q45UPSD is equipped with a 0-5 V DC pressure sensor. The Node's register 2 reports this output as a raw value. Use the following equations to interpret the raw value in PSIG or PSIS.

**Table 2:** Example pressure calculations

Model	Divide the Value in Register 2 by	Example
0-50 PSIG	655.35	PSI = 13265 (holding register 2 in decimal) ÷ 655.35 = 20.2 PSIG
0-150 PSIG	218.45	PSI = 13265 (holding register 2 in decimal) ÷ 218.45 = 60.7 PSIG
0-500 PSIS	65.535	PSI = 13265 (holding register 2 in decimal) ÷ 65.535 = 202 PSIS
0-3000 PSIS	10.9225	PSI = 13265 (holding register 2 in decimal) ÷ 10.9225 = 1214 PSIS

## Specifications

### Performance Radio with Internal Antenna Specifications

**Radio Range**

900 MHz, 1 Watt: Up to 3.2 km (2 miles) with line of sight (internal antenna)  
 2.4 GHz, 65 mW: Up to 1000 m (3280 ft) with line of sight (internal antenna)  
 Range depends on the environment and decreases significantly without line of sight. Always verify your wireless network's range by performing a Site Survey.

**Radio Transmit Power**

900 MHz, 1 Watt: 30 dBm (1 W) conducted (up to 36 dBm EIRP)  
 2.4 GHz, 65 mW: 18 dBm (65 mW) conducted, less than or equal to 20 dBm (100 mW) EIRP

**900 MHz Compliance (1 Watt)**

Contains FCC ID: UE3RM1809: FCC Part 15, Subpart C, 15.247  
 Contains IC: 7044A-RM1809  
 IFT: RCPBARM13-2283



(NOM approval only applies to 900 MHz models)

**Antenna Minimum Separation Distance**

900 MHz, 1 Watt: 4.57 m (15 ft)  
 2.4 GHz, 65 mW: 0.3 m (1 ft)

**Link Timeout (Performance)**

Gateway: Configurable via User Configuration Software  
 Node: Defined by Gateway

**Spread Spectrum Technology**

FHSS (Frequency Hopping Spread Spectrum)

**2.4 GHz Compliance (SX243 Radio Module)**

Radio module is indicated by the product label marking  
 Contains FCC ID: UE3SX243: FCC Part 15, Subpart C, 15.247  
 Radio Equipment Directive (RED) 2014/53/EU  
 Contains IC: 7044A-SX243  
 ANATEL: 03737-22-04042 Este equipamento não tem direito à proteção contra interferência prejudicial e não pode causar interferência em sistemas devidamente autorizados. Para maiores informações, consulte o site da ANATEL [www.gov.br/anatel/pt-br/](http://www.gov.br/anatel/pt-br/)



## Q45UPSD Specifications

### Housing

Molded reinforced thermoplastic polyester housing, o-ring-sealed transparent Lexan® cover, molded acrylic lenses, and stainless steel hardware  
Integral nickel-plated female M12 quick-disconnect connector

### Default Sensing Interval

5 minutes

### Typical Battery Life

See chart

### Indicators

Red and green LEDs (radio function)



**Banner Engineering Europe**  
Park Lane, Culliganlaan 2F  
bus 3, 1831 Diegem,  
BELGIUM



**Turck Banner LTD** Blenheim  
House, Blenheim Court,  
Wickford, Essex SS11 8YT,  
Great Britain

(CE/UKCA approval only  
applies to 2.4 GHz models)

## Environmental Specifications for the Q45

### Operating Conditions

-40 °C to +70 °C (-40 °F to +158 °F); 90% at +50 °C maximum relative humidity (non-condensing)  
Radiated Immunity: 10 V/m (EN 61000-4-3)

### Environmental Rating

NEMA 6P, IP67

Operating the devices at the maximum operating conditions for extended periods can shorten the life of the device.

## Dimensions

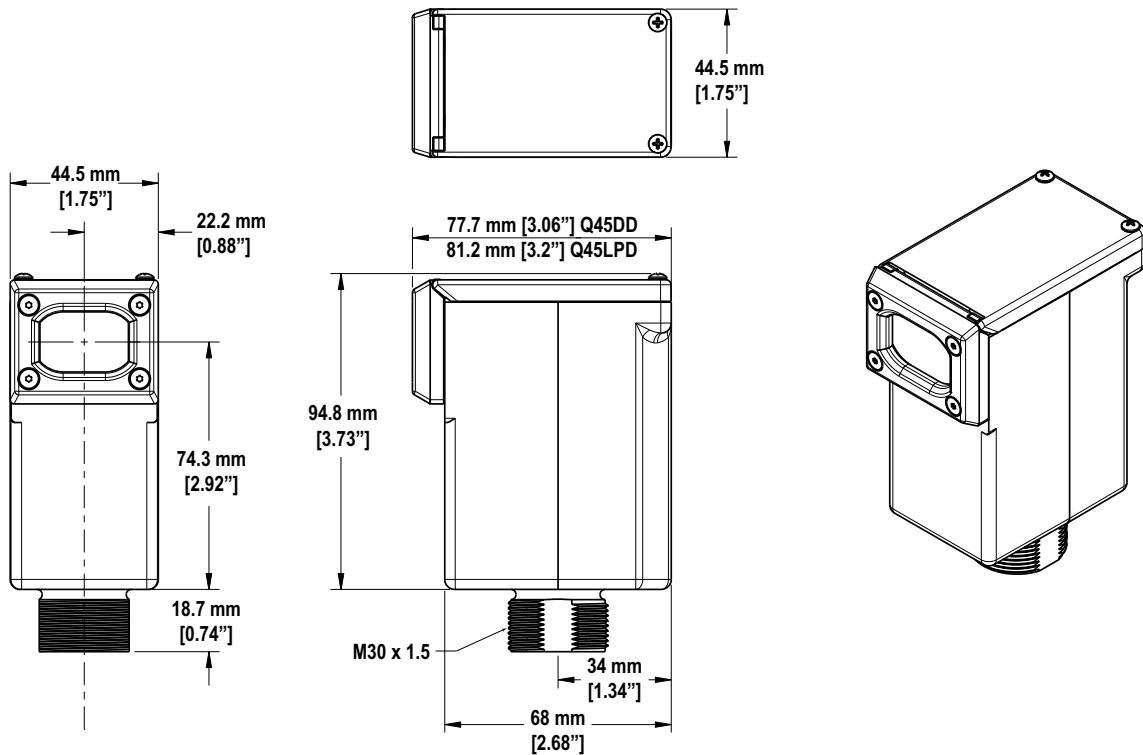

Figure 1: Dimensions for the Q45UPSD

## Battery Life

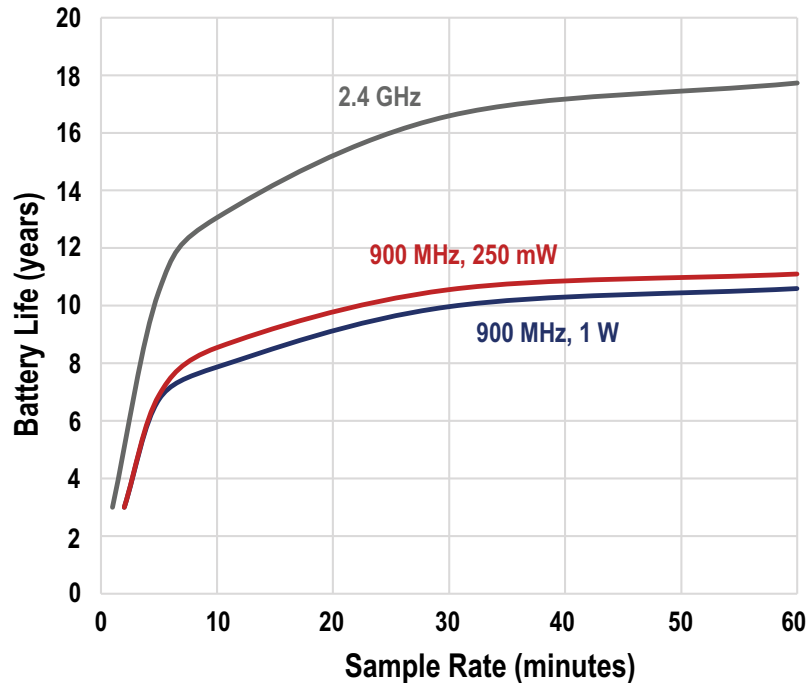

Figure 2: Battery life for the Q45UPSD Node

## Accessories

### Replacement Batteries

#### BWA-BATT-011 Battery

- 3.6 V Lithium D cell for non-hazardous locations only
- 19000 mAh
- One battery



## Warnings

**Exporting Sure Cross® Radios.** It is our intent to fully comply with all national and regional regulations regarding radio frequency emissions. **Customers who want to re-export this product to a country other than that to which it was sold must ensure the device is approved in the destination country.** The Sure Cross wireless products were certified for use in these countries using the antenna that ships with the product. When using other antennas, verify you are not exceeding the transmit power levels allowed by local governing agencies. This device has been designed to operate with the antennas listed on Banner Engineering's website and having a maximum gain of 9 dBm. Antennas not included in this list or having a gain greater than 9 dBm are strictly prohibited for use with this device. The required antenna impedance is 50 ohms. To reduce potential radio interference to other users, the antenna type and its gain should be so chosen such that the equivalent isotropically radiated power (EIRP) is not more than that permitted for successful communication. Consult with Banner Engineering Corp. if the destination country is not on this list.

**IMPORTANT:** Please download the complete Wireless Q45UPSD Universal Pressure Monitoring Node technical documentation, available in multiple languages, from [www.bannerengineering.com](http://www.bannerengineering.com) for details on the proper use, applications, Warnings, and installation instructions of this device.

**IMPORTANT:** Por favor descargue desde [www.bannerengineering.com](http://www.bannerengineering.com) toda la documentación técnica de los Wireless Q45UPSD Universal Pressure Monitoring Node, disponibles en múltiples idiomas, para detalles del uso adecuado, aplicaciones, advertencias, y las instrucciones de instalación de estos dispositivos.

**IMPORTANT:** Veuillez télécharger la documentation technique complète des Wireless Q45UPSD Universal Pressure Monitoring Node sur notre site [www.bannerengineering.com](http://www.bannerengineering.com) pour les détails sur leur utilisation correcte, les applications, les notes de sécurité et les instructions de montage.



## WARNING

### DO NOT USE THIS DEVICE FOR PERSONNEL PROTECTION

Using this device for personnel protection could result in serious injury or death.

- This device does not include the self-checking redundant circuitry necessary to allow its use in personnel safety applications. A device failure or malfunction can cause either an energized (on) or de-energized (off) output condition.

### ELECTROSTATIC DISCHARGE (ESD) SENSITIVE DEVICE

ESD can damage the device. Damage from inappropriate handling is not covered by warranty.

- Use proper handling procedures to prevent ESD damage. Proper handling procedures include leaving devices in their anti-static packaging until ready for use; wearing anti-static wrist straps; and assembling units on a grounded, static-dissipative surface.

## Banner Engineering Corp. Limited Warranty

Banner Engineering Corp. warrants its products to be free from defects in material and workmanship for one year following the date of shipment. Banner Engineering Corp. will repair or replace, free of charge, any product of its manufacture which, at the time it is returned to the factory, is found to have been defective during the warranty period. This warranty does not cover damage or liability for misuse, abuse, or the improper application or installation of the Banner product.

**THIS LIMITED WARRANTY IS EXCLUSIVE AND IN LIEU OF ALL OTHER WARRANTIES WHETHER EXPRESS OR IMPLIED (INCLUDING, WITHOUT LIMITATION, ANY WARRANTY OF MERCHANTABILITY OR FITNESS FOR A PARTICULAR PURPOSE), AND WHETHER ARISING UNDER COURSE OF PERFORMANCE, COURSE OF DEALING OR TRADE USAGE.**

This Warranty is exclusive and limited to repair or, at the discretion of Banner Engineering Corp., replacement. **IN NO EVENT SHALL BANNER ENGINEERING CORP. BE LIABLE TO BUYER OR ANY OTHER PERSON OR ENTITY FOR ANY EXTRA COSTS, EXPENSES, LOSSES, LOSS OF PROFITS, OR ANY INCIDENTAL, CONSEQUENTIAL OR SPECIAL DAMAGES RESULTING FROM ANY PRODUCT DEFECT OR FROM THE USE OR INABILITY TO USE THE PRODUCT, WHETHER ARISING IN CONTRACT OR WARRANTY, STATUTE, TORT, STRICT LIABILITY, NEGLIGENCE, OR OTHERWISE.**

Banner Engineering Corp. reserves the right to change, modify or improve the design of the product without assuming any obligations or liabilities relating to any product previously manufactured by Banner Engineering Corp. Any misuse, abuse, or improper application or installation of this product or use of the product for personal protection applications when the product is identified as not intended for such purposes will void the product warranty. Any modifications to this product without prior express approval by Banner Engineering Corp will void the product warranties. All specifications published in this document are subject to change; Banner reserves the right to modify product specifications or update documentation at any time. Specifications and product information in English supersede that which is provided in any other language. For the most recent version of any documentation, refer to: [www.bannerengineering.com](http://www.bannerengineering.com).

For patent information, see [www.bannerengineering.com/patents](http://www.bannerengineering.com/patents).

## FCC Part 15 Class A

This equipment has been tested and found to comply with the limits for a Class A digital device, pursuant to part 15 of the FCC Rules. These limits are designed to provide reasonable protection against harmful interference when the equipment is operated in a commercial environment. This equipment generates, uses, and can radiate radio frequency energy and, if not installed and used in accordance with the instruction manual, may cause harmful interference to radio communications. Operation of this equipment in a residential area is likely to cause harmful interference in which case the user will be required to correct the interference at his own expense.

## Industry Canada

This device contains licence-exempt transmitters(s)/receiver(s) that comply with Innovation, Science and Economic Development Canada's licence-exempt RSS(s). Operation is subject to the following two conditions:

- 1) This device may not cause interference.
- 2) This device must accept any interference, including interference that may cause undesired operation of the device.

Cet appareil contient des émetteurs/récepteurs exemptés de licence conformes à la norme Innovation, Sciences, et Développement économique Canada. L'exploitation est autorisée aux deux conditions suivantes:

- 1) L'appareil ne doit pas produire de brouillage.
- 2) L'utilisateur de l'appareil doit accepter tout brouillage radioélectrique subi, même si le brouillage est susceptible d'en compromettre le fonctionnement.

## Notas Adicionales

Información México: La operación de este equipo está sujeta a las siguientes dos condiciones: 1) es posible que este equipo o dispositivo no cause interferencia perjudicial y 2) este equipo debe aceptar cualquier interferencia, incluyendo la que pueda causar su operación no deseada.

Banner es una marca registrada de Banner Engineering Corp. y podrán ser utilizadas de manera indistinta para referirse al fabricante. "Este equipo ha sido diseñado para operar con las antenas tipo Omnidireccional para una ganancia máxima de antena de 6 dBd y Yagi para una



ganancia máxima de antena 10 dBd que en seguida se enlistan. También se incluyen aquellas con aprobación ATEX tipo Omnidireccional siempre que no excedan una ganancia máxima de antena de 6dBd. El uso con este equipo de antenas no incluidas en esta lista o que tengan una ganancia mayor que 6 dBd en tipo omnidireccional y 10 dBd en tipo Yagi, quedan prohibidas. La impedancia requerida de la antena es de 50 ohms."

## Mexican Importer

Banner Engineering de México, S. de R.L. de C.V.  
David Alfaro Siqueiros 103 Piso 2 Valle oriente  
San Pedro Garza Garcia Nuevo León, C. P. 66269  
81 8363.2714

Document title: Q45UPSD Universal Pressure Monitoring Node  
Part number: 225484  
Revision: C  
Original Instructions  
© Banner Engineering Corp. All rights reserved.

