

## Dual Full Bridge Low Voltage Motor Driver

### FEATURES AND BENEFITS

- Low  $R_{DS(on)}$  outputs
- Full- and half-stepping capability
- Small package
- Forward, reverse, and brake modes for DC motors
- Sleep mode with zero current drain
- PWM control up to 250 kHz
- Crossover-current protection
- Thermal shutdown (TSD)

### PACKAGE: 10-Contact DFN (suffix EJ)

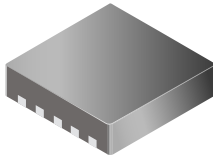

Not to scale

### DESCRIPTION

The A3901 is a dual full-bridge motor driver, designed for low voltage portable applications involving bipolar stepper or brush DC motors. The outputs have been optimized for low voltage drop, with currents up to  $\pm 400$  mA ( $\pm 800$  mA with outputs paralleled) and an operating voltage range of 2.5 to 5.5 V.

The four inputs (IN1 to IN4) can control a bipolar stepper motor in full- or half-step mode, or DC motors in forward, reverse, or brake mode. The inputs can be PWMed for current or speed control at frequencies up to 250 kHz.

Internal protection circuitry includes thermal shut down (TSD) and crossover (shoot-through) protection.

The A3901 is supplied in a 3 mm  $\times$  3 mm  $\times$  0.75 mm nominal height, 10-lead DFN package, with exposed thermal pad (package "EJ"). This small footprint package is lead (Pb) free, with 100% matte tin leadframe plating.

### Typical Applications

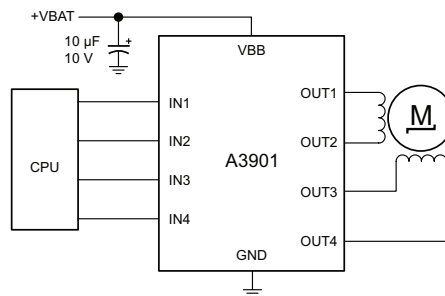

Figure 1. Typical stepper motor control

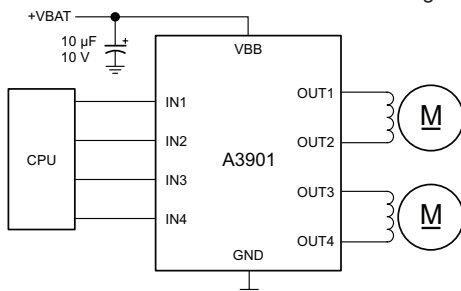

Figure 2. Typical dual DC motor control

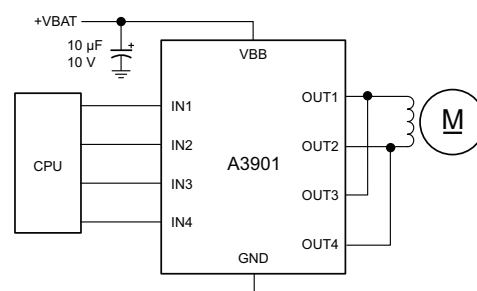

Figure 3. Typical single DC motor control (paralleled outputs)

**SELECTION GUIDE**

| Part Number  | Packing                         |
|--------------|---------------------------------|
| A3901SEJTR-T | Tape and reel, 1500 pieces/reel |

**ABSOLUTE MAXIMUM RATINGS**

| Parameter                   | Symbol    | Conditions | Min. | Typ. | Max. | Units |
|-----------------------------|-----------|------------|------|------|------|-------|
| Load Supply Voltage         | $V_{BB}$  |            | –    | –    | 7    | V     |
| Output Current per Channel* | $I_{OUT}$ |            | –    | –    | 400  | mA    |
| Logic Input Voltage Range   | $V_{IN}$  |            | –0.3 | –    | 6    | V     |
| Junction Temperature        | $T_J$     |            | –    | –    | 150  | °C    |
| Storage Temperature Range   | $T_{stg}$ |            | –55  | –    | 150  | °C    |
| Operating Temperature Range | $T_A$     |            | –20  | –    | 85   | °C    |

\*Output current rating may be limited by duty cycle, ambient temperature, and heat sinking. Under any set of conditions, do not exceed the specified current rating or a junction temperature of 150°C.

## FUNCTIONAL BLOCK DIAGRAM

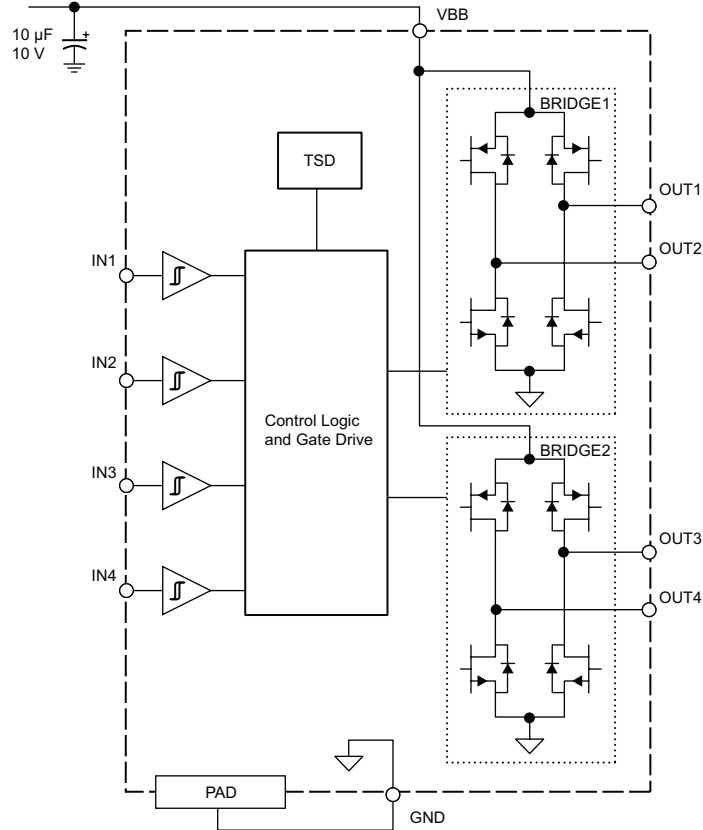

## TERMINAL DIAGRAM

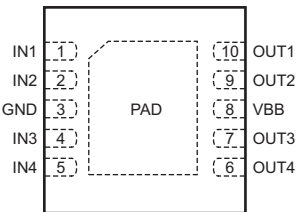

| Number | Name | Description  |
|--------|------|--|
| 1      | IN1  | Logic input 1  |
| 2      | IN2  | Logic input 2  |
| 3      | GND  | Ground terminal  |
| 4      | IN3  | Logic input 3  |
| 5      | IN4  | Logic input 4  |
| 6      | OUT4 | Bridge2 output to load   |
| 7      | OUT3 | Bridge2 output to load   |
| 8      | VBB  | Load supply terminal   |
| 9      | OUT2 | Bridge1 output to load   |
| 10     | OUT1 | Bridge1 output to load   |
| -      | Pad  | Exposed pad for thermal dissipation; connect to GND externally |

**ELECTRICAL CHARACTERISTICS at  $T_A=25^\circ\text{C}$ , and  $V_{BB} = 2.5$  to  $5.5$  V, unless noted otherwise**

| Characteristics               | Symbol        | Test Conditions                                   | Min.       | Typ.  | Max. | Units            |
|-------------------------------|---------------|---|------------|-------|------|------------------|
| Output On Resistance          | $R_{DS(on)}$  | Source driver, $V_{BB} = 3$ V, $I_{OUT} = 300$ mA | 1          | 1.8   | 2.2  | $\Omega$         |
|                               |               | Source driver, $V_{BB} = 5$ V, $I_{OUT} = 300$ mA | 1          | 1.2   | 1.4  | $\Omega$         |
|                               |               | Sink driver, $V_{BB} = 3$ V, $I_{OUT} = 300$ mA   | 0.5        | 1.2   | 1.4  | $\Omega$         |
|                               |               | Sink driver, $V_{BB} = 5$ V, $I_{OUT} = 300$ mA   | 0.5        | 0.8   | 1.0  | $\Omega$         |
| Clamp Diode                   |               | $I = 300$ mA                                      | –          | –     | 1.5  | V                |
| Motor Supply Current          | $I_{BB}$      | All outputs PWMed at 20 kHz                       | –          | 0.6   | –    | mA               |
|                               |               | Sleep mode, $V_{BB} = 3$ V                        | –          | –     | 100  | nA               |
|                               |               | Sleep mode, $V_{BB} = 5$ V                        | –          | <50   | 500  | nA               |
| Logic Input Voltage           | $V_{IN(1)}$   |   | $V_{BB}/2$ | –     | –    | V                |
|                               | $V_{IN(0)}$   |   | –          | –     | 0.5  | V                |
| Logic Input Current           | $I_{IN(1)}$   | $V_{IN} = 2.0$ V                                  | –          | <100  | 500  | nA               |
|                               | $I_{IN(0)}$   | $V_{IN} = 0.5$ V                                  | –          | <–100 | –500 | nA               |
| Input Voltage Hysteresis      | $V_{hys}$     |   | –          | 150   | –    | mV               |
| Propagation Delay             | $t_{pd(on)}$  | Input Low to Sink On, Input High to Source On     | –          | 130   | –    | ns               |
|                               | $t_{pd(off)}$ | Input High to Sink Off, Input Low to Source Off   | –          | 50    | –    | ns               |
| Crossover Delay               | $t_{COD}$     |   | –          | 80    | –    | ns               |
| Thermal Shut Down Temperature | $T_J$         |   | –          | 150   | –    | $^\circ\text{C}$ |
| Thermal Shut Down Hysteresis  | $T_{Jhys}$    |   | –          | 10    | –    | $^\circ\text{C}$ |

| THERMAL CHARACTERISTICS     |                 |  |        |                           |
|-----------------------------|-----------------|--|--------|---------------------------|
| Characteristics             | Symbol          | Test Conditions  | Rating | Unit                      |
| Package Thermal Resistance* | $R_{\theta JA}$ | Measured on 4-layer board based on JEDEC standard  | 45     | $^\circ\text{C}/\text{W}$ |
|                             |                 | Measured on 2-layer board with copper limited to solder pads and 0.88 in <sup>2</sup> . of copper on each side | 65     | $^\circ\text{C}/\text{W}$ |

\*Additional thermal information is available on the Allegro Web site.

MOTOR OPERATION TRUTH TABLE

| IN <sub>x</sub> <sup>1</sup>         |     |             |     | OUT1 <sup>2</sup> | OUT2 | OUT3 | OUT4 | Function                |               |
|--------------------------------------|-----|-------------|-----|-------------------|------|------|------|-------------------------|---------------|
| <b>Stepper Motor</b>                 |     |             |     |                   |      |      |      |                         |               |
| IN1                                  | IN2 | IN3         | IN4 |                   |      |      |      | Full Stepping           | Half-Stepping |
| 0                                    | 0   | 0           | 0   | OFF               | OFF  | OFF  | OFF  | Sleep Mode              | Sleep Mode    |
| 1                                    | 0   | 1           | 0   | H                 | L    | H    | L    | Step 1                  | Step 1        |
| 0                                    | 0   | 1           | 0   | OFF               | OFF  | H    | L    | –                       | Step 2        |
| 0                                    | 1   | 1           | 0   | L                 | H    | H    | L    | Step 2                  | Step 3        |
| 0                                    | 1   | 0           | 0   | L                 | H    | OFF  | OFF  | –                       | Step 4        |
| 0                                    | 1   | 0           | 1   | L                 | H    | L    | H    | Step 3                  | Step 5        |
| 0                                    | 0   | 0           | 1   | OFF               | OFF  | L    | H    | –                       | Step 6        |
| 1                                    | 0   | 0           | 1   | H                 | L    | L    | H    | Step 4                  | Step 7        |
| 1                                    | 0   | 0           | 0   | H                 | L    | OFF  | OFF  | –                       | Step 8        |
| <b>DC Motor (Dual)</b>               |     |             |     |                   |      |      |      |                         |               |
| IN1 or IN3                           |     | IN2 or IN4  |     |                   |      |      |      |                         |               |
| 0                                    |     | 0           |     | OFF               | OFF  | OFF  | OFF  | Hi-Z (Sleep Mode)/Coast |               |
| 1                                    |     | 0           |     | H                 | L    | H    | L    | Forward                 |               |
| 0                                    |     | 1           |     | L                 | H    | L    | H    | Reverse                 |               |
| 1                                    |     | 1           |     | L                 | L    | L    | L    | Brake                   |               |
| <b>DC Motor (Single, Paralleled)</b> |     |             |     |                   |      |      |      |                         |               |
| IN1 and IN3                          |     | IN2 and IN4 |     |                   |      |      |      |                         |               |
| 0                                    |     | 0           |     | OFF               | OFF  | OFF  | OFF  | Hi-Z (Sleep Mode)/Coast |               |
| 1                                    |     | 0           |     | H                 | L    | H    | L    | Forward                 |               |
| 0                                    |     | 1           |     | L                 | H    | L    | H    | Reverse                 |               |
| 1                                    |     | 1           |     | L                 | L    | L    | L    | Brake                   |               |
| <b>DC Motor (External PWM)</b>       |     |             |     |                   |      |      |      |                         |               |
| IN1 or IN3                           |     | IN2 or IN4  |     |                   |      |      |      |                         |               |
| 1                                    |     | 0           |     | H                 | L    | H    | L    | Forward                 |               |
| 0                                    |     | 0           |     | OFF               | OFF  | OFF  | OFF  | Fast Decay              |               |
| 0                                    |     | 1           |     | L                 | H    | L    | H    | Reverse                 |               |
| 0                                    |     | 0           |     | OFF               | OFF  | OFF  | OFF  | Fast Decay              |               |
| 1                                    |     | 0           |     | H                 | L    | H    | L    | Forward                 |               |
| 1                                    |     | 1           |     | L                 | L    | L    | L    | Slow Decay              |               |
| 0                                    |     | 1           |     | L                 | H    | L    | H    | Reverse                 |               |
| 1                                    |     | 1           |     | L                 | L    | L    | L    | Slow Decay              |               |

<sup>1</sup>0 = logic low,  $V_{INx} < V_{IN(0)(max)}$ ; 1 = logic high,  $V_{INx} > V_{IN(1)(min)}$

<sup>2</sup>H = voltage high, source driver on; L = voltage low, sink driver on

CHARACTERISTIC PERFORMANCE

Output On Resistance versus Load Supply Voltage  
 $I_{OUT} = 100 \text{ mA}$

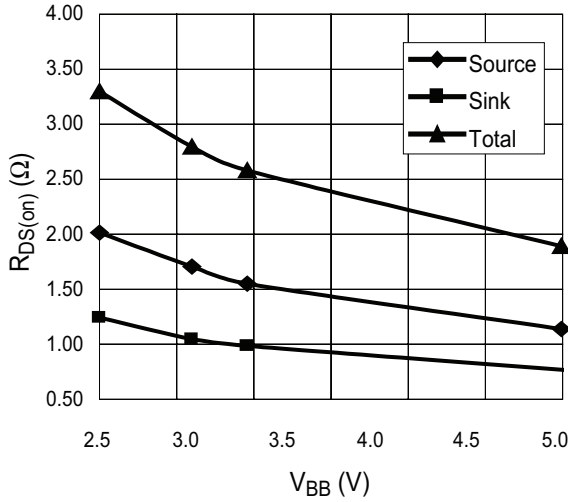

Output On Resistance versus Load Supply Voltage  
 $I_{OUT} = 300 \text{ mA}$

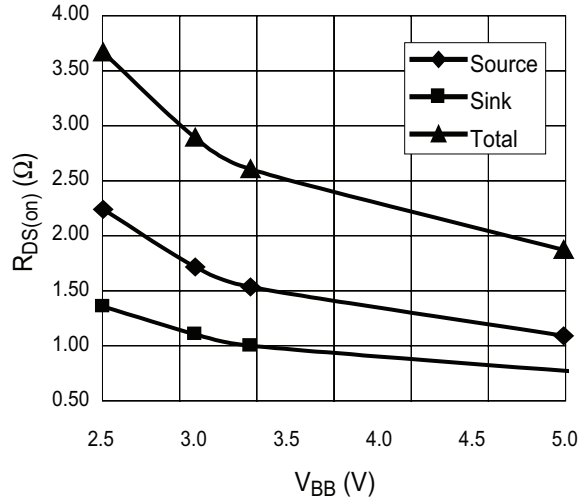

Output On Resistance versus Output Current  
 $V_{BB} = 3 \text{ V}$

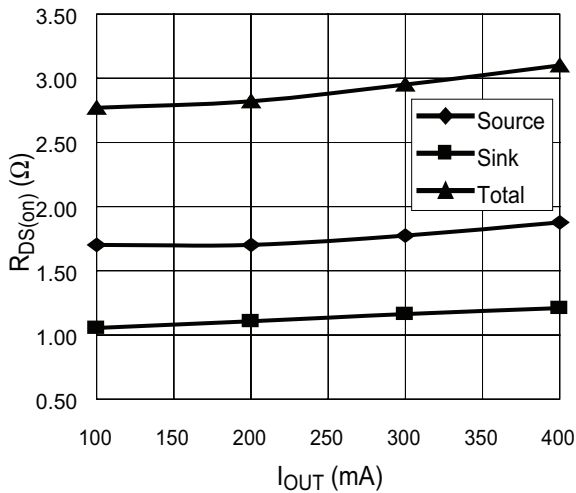

Output On Resistance versus Output Current  
 $V_{BB} = 5 \text{ V}$

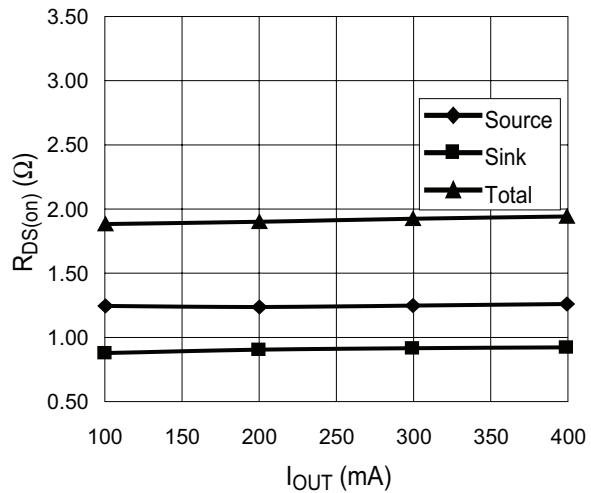

**FUNCTIONAL DESCRIPTION**

**Device Operation.** The A3901 is a dual full-bridge low voltage motor driver capable of operating one stepper motor or up to two DC motors. MOSFET output stages substantially reduce the voltage drop and the power dissipation of the outputs of the A3901 compared to typical drivers with bipolar transistors.

Internal circuit protection includes thermal shutdown with hysteresis, clamp diodes, and crossover current protection.

The A3901 is designed for portable applications with a power-off (Sleep mode) current of 50 nA typical, and an operating voltage of 2.5 to 5.5 V. The A3901 logic inputs are 3 to 5 V logic compatible.

Output current can be regulated by pulse width modulating (PWM) the inputs. The full-bridge outputs can be paralleled for higher-current applications (see figure 6).

In conditions where the logic supply voltage drops below 2.5 V, both the sink and the source  $R_{DS(on)}$  will increase beyond the specified values. In extreme cases, no power will be delivered to the motor(s). However, the device will not be damaged.

In stepping operation, the device can drive in either full- or half-step mode. The stepping mode is set by

the signal pattern on the INx terminals, as shown in the stepping timing diagrams.

**External PWM.** Pulse width modulating the inputs allows the output current to be regulated. Slow decay mode is achieved by holding one input high while PWMing the other input. Holding one input low and PWMing the other input results in fast decay. See the External PWM diagram.

**Sleep Mode.** Pulling all inputs to 0.5 V or less, sends the A3901 into Sleep mode, during which it draws 50 nA typical.

**Thermal Shutdown.** The A3901 will disable the outputs if the junction temperature reaches 165°C. When thermal shutdown is entered, after the junction temperature drops 15°C, the outputs will be re-enabled.

**Brake Mode.** When driving DC motors, the A3901 will go into Brake mode (turn on both sink drivers) when all inputs, INx, are logic 1. There is no protection during braking, so care must be taken to ensure that the peak current during braking does not exceed the absolute maximum current.

APPLICATION INFORMATION

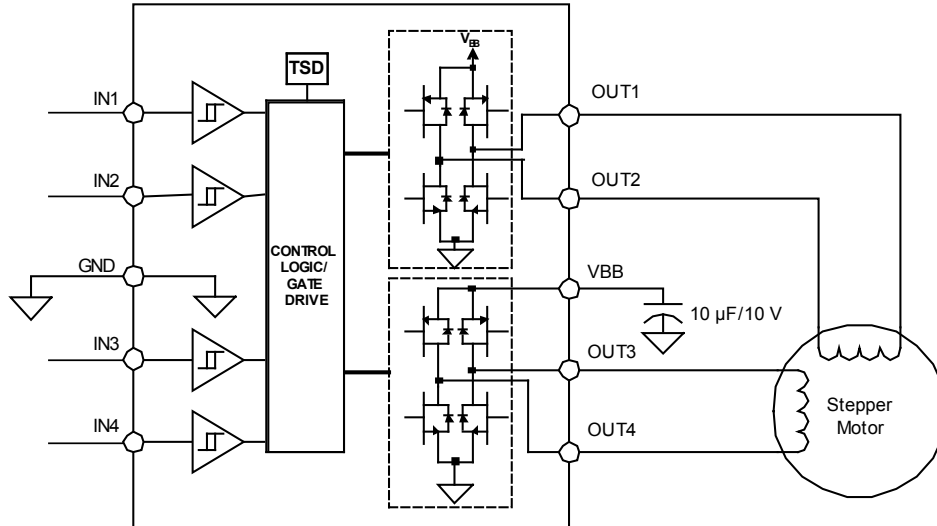

Figure 4a. Typical stepper motor control application

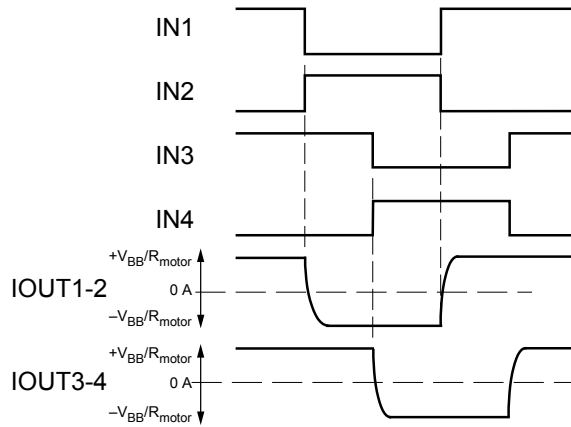

Figure 4b. Full step mode timing chart

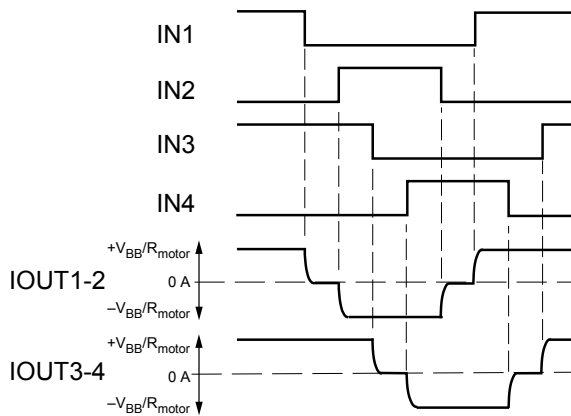

Figure 4c. Half step mode timing chart



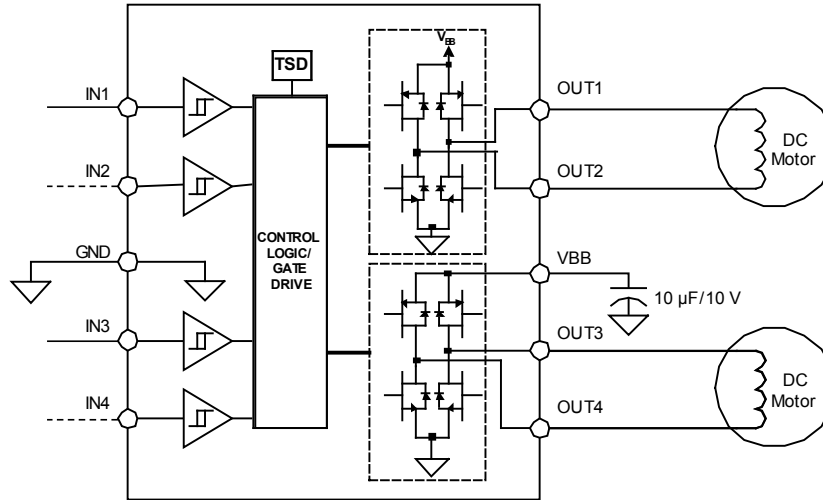

Figure 5. Typical dual DC motor control application. Either IN1 or IN2 can be used to drive OUT1 and OUT2. Either IN3 or IN4 can be used to drive OUT3 and OUT4.

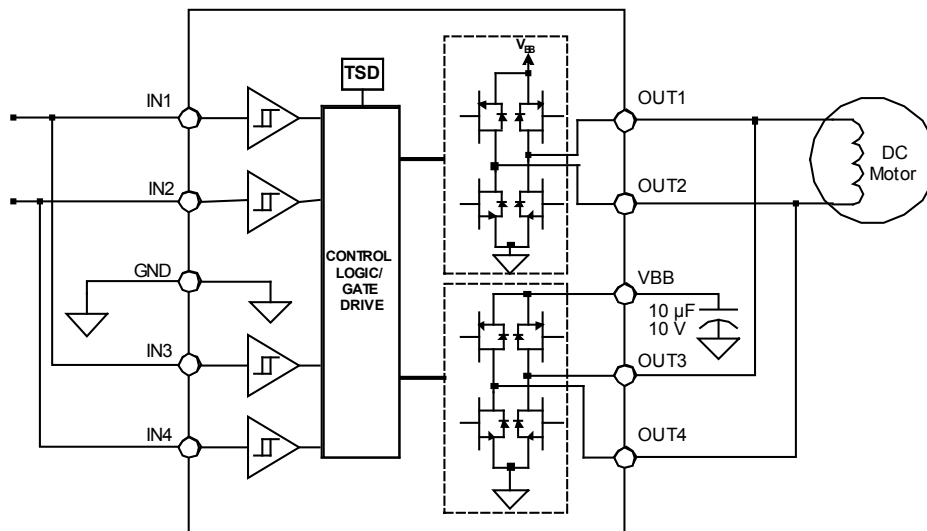

Figure 6. Typical single DC motor control (paralleled outputs)

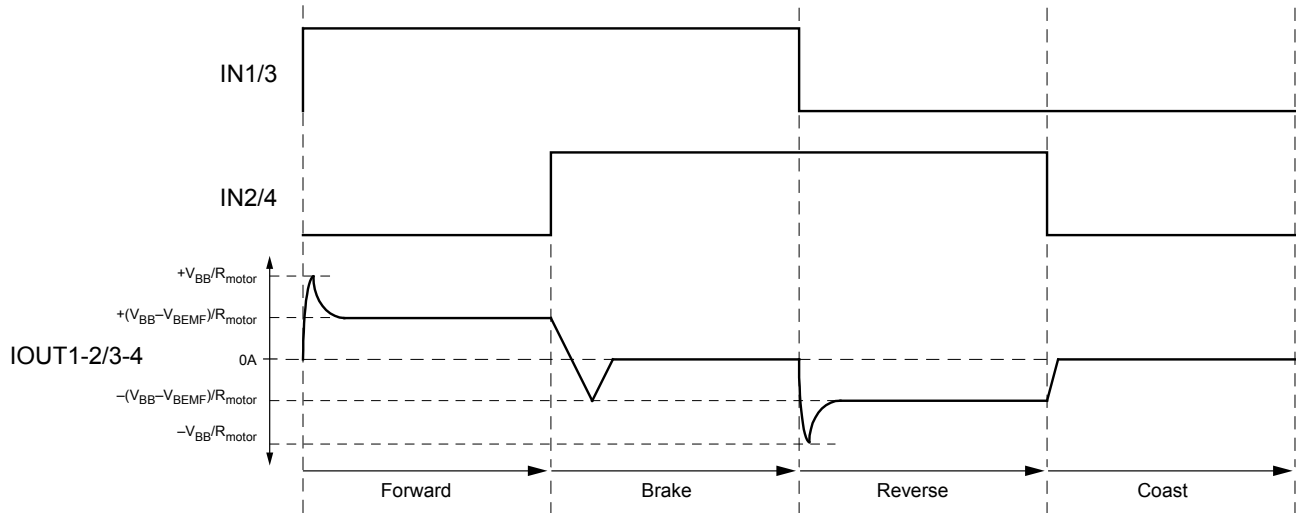

Figure 7. Typical dual DC motor control application

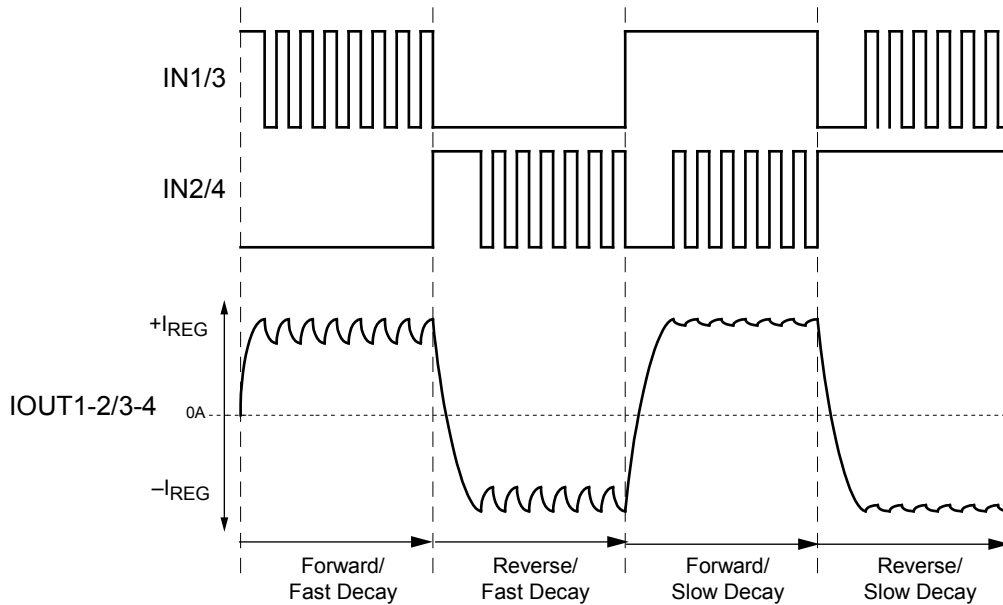
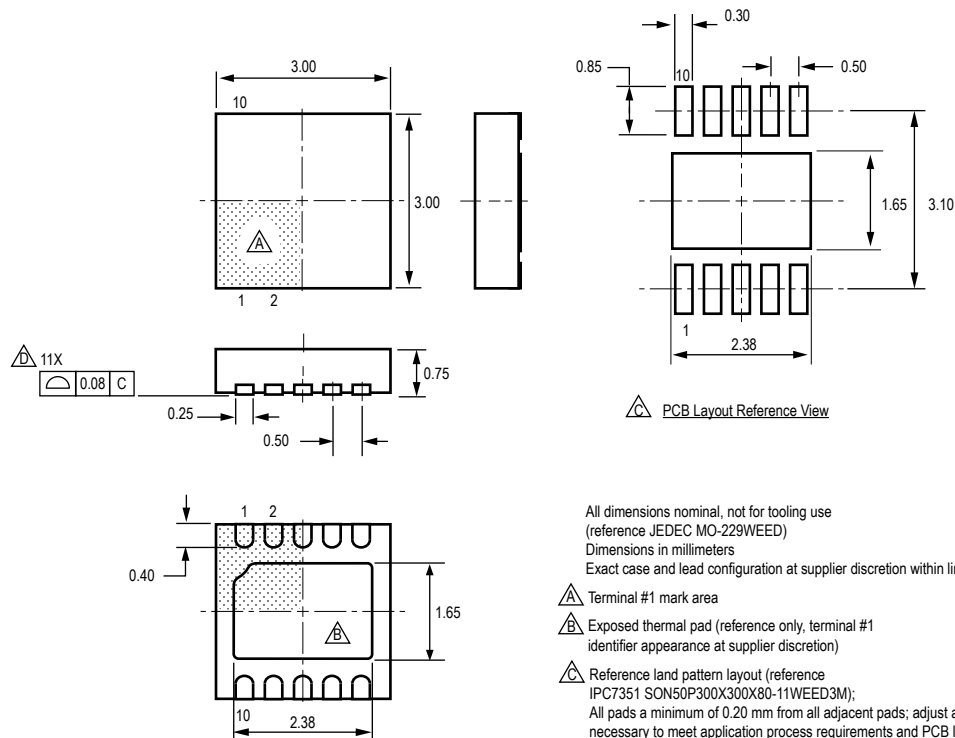

Figure 8. External PWM current control in fast and slow decay modes

## Package EJ, 10-contact DFN



All dimensions nominal, not for tooling use  
 (reference JEDEC MO-229WEED)  
 Dimensions in millimeters  
 Exact case and lead configuration at supplier discretion within limits shown

- △ Terminal #1 mark area
- △ Exposed thermal pad (reference only, terminal #1 identifier appearance at supplier discretion)
- △ Reference land pattern layout (reference IPC7351 SON50P300X300X80-11WEED3M); All pads a minimum of 0.20 mm from all adjacent pads; adjust as necessary to meet application process requirements and PCB layout tolerances; when mounting on a multilayer PCB, thermal vias at the exposed thermal pad land can improve thermal dissipation (reference EIA/JEDEC Standard JESD51-5)
- △ Coplanarity includes exposed thermal pad and terminals

**Revision History**

| <b>Number</b> | <b>Date</b>      | <b>Description</b>  |
|---------------|------------------|---|
| 4             | June 19, 2013    | Update $R_{DS(on)}$ specifications                          |
| 5             | February 7, 2014 | Updated Electrical Characteristics and disclaimer statement |
| 6             | March 12, 2019   | Minor editorial updates                                     |

Copyright 2019, Allegro MicroSystems, LLC

Allegro MicroSystems, LLC reserves the right to make, from time to time, such departures from the detail specifications as may be required to permit improvements in the performance, reliability, or manufacturability of its products. Before placing an order, the user is cautioned to verify that the information being relied upon is current.

Allegro's products are not to be used in any devices or systems, including but not limited to life support devices or systems, in which a failure of Allegro's product can reasonably be expected to cause bodily harm.

The information included herein is believed to be accurate and reliable. However, Allegro MicroSystems, LLC assumes no responsibility for its use; nor for any infringement of patents or other rights of third parties which may result from its use.

Copies of this document are considered uncontrolled documents.

For the latest version of this document, visit our website:

[www.allegromicro.com](http://www.allegromicro.com)