



M3K Features

- Available in incremental and incremental/absolute configurations
- Push-on hub spring loaded collet design
- Motor shaft length of 0.500 in. or 0.390 in.
- Fits shaft diameters from 3mm to 0.250 in.
- 1 to 8,192 cycles per revolution (CPR)
- 4 to 32,768 pulses per revolution (PPR)
- A/B/Index incremental output and 12-bit PWM output for absolute position
- Latching connector
- Single 4~16V supply
- 5V logic level outputs



M3K Product Description

The M3K miniature magnetic kit encoder is designed to provide shaft position feedback for high volume, restricted space applications. The M3K outputs A, B, and Index digital quadrature signals and optional pulse width modulated (PWM) absolute position. The PWM output provides a pulse width duty cycle that is proportional to the absolute shaft position.



The M3K features a push-on hub design that can easily mount from 3mm to 0.250 in. diameter shafts. The M3K consists of three components: base, push-on magnetic hub, and encoder body. Various base options accommodate different length shafts, including a 0.586 in. or 0.750 in. bolt circle. No tools are required to install the push-on, collet-gripping hub, making assembly very easy. The hub mounts to a standard shaft in seconds and provides a simple and reliable means of securing the magnet to the shaft. Two mounting screws are provided that secure the base and encoder body.

The M3K miniature magnetic encoder is connected using a Molex PicoClasp (#5013300600) 6-conductor, polarized, 1mm pitch latching connector. Mating cables and connectors (see the Cables (<https://www.usdigital.com/products/accessories/cables/>)/Connectors (<https://www.usdigital.com/products/accessories/connectors/>) web page) are not included and are available separately.

Please Note: Due to the M3K's design, it is recommended for a one-time installation.

Mechanical Drawings

M3K Miniature Magnetic Incremental Kit Encoder

M3K Magnetic Kit Encoder (5-Option Bolt Circle)

RELEASE DATE: 1/7/2021

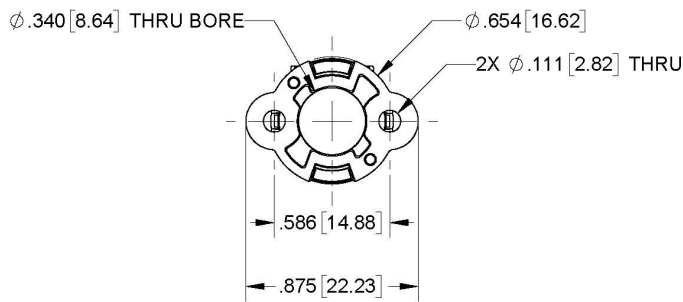
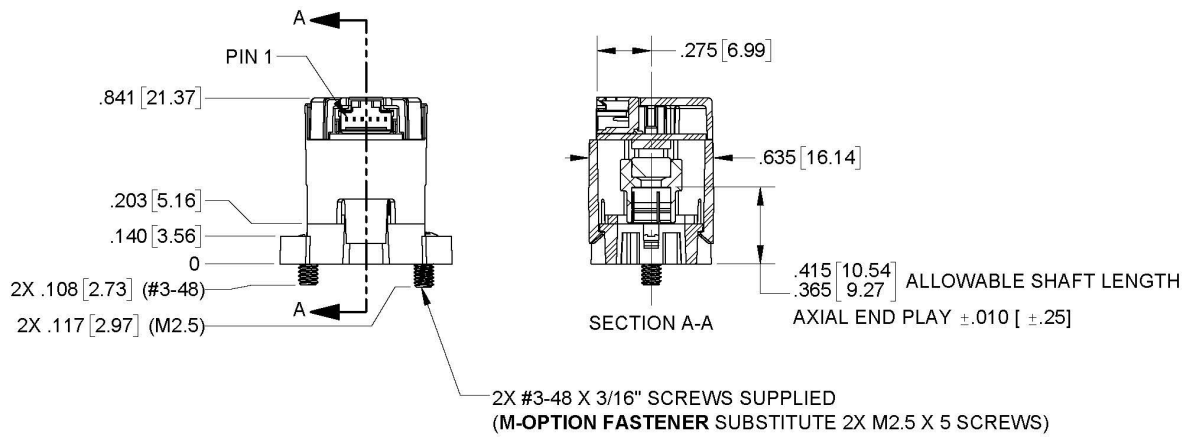

US DIGITAL 1400 NE 136th Avenue
Vancouver, Washington 98684, USA

info@usdigital.com
www.usdigital.com

Local: 360.260.2468
Toll-free: 800.736.0194

UNITS: INCHES [MM]
METRIC SHOWN FOR REFERENCE ONLY

M3K Magnetic Kit Encoder (7-Option Bolt Circle)

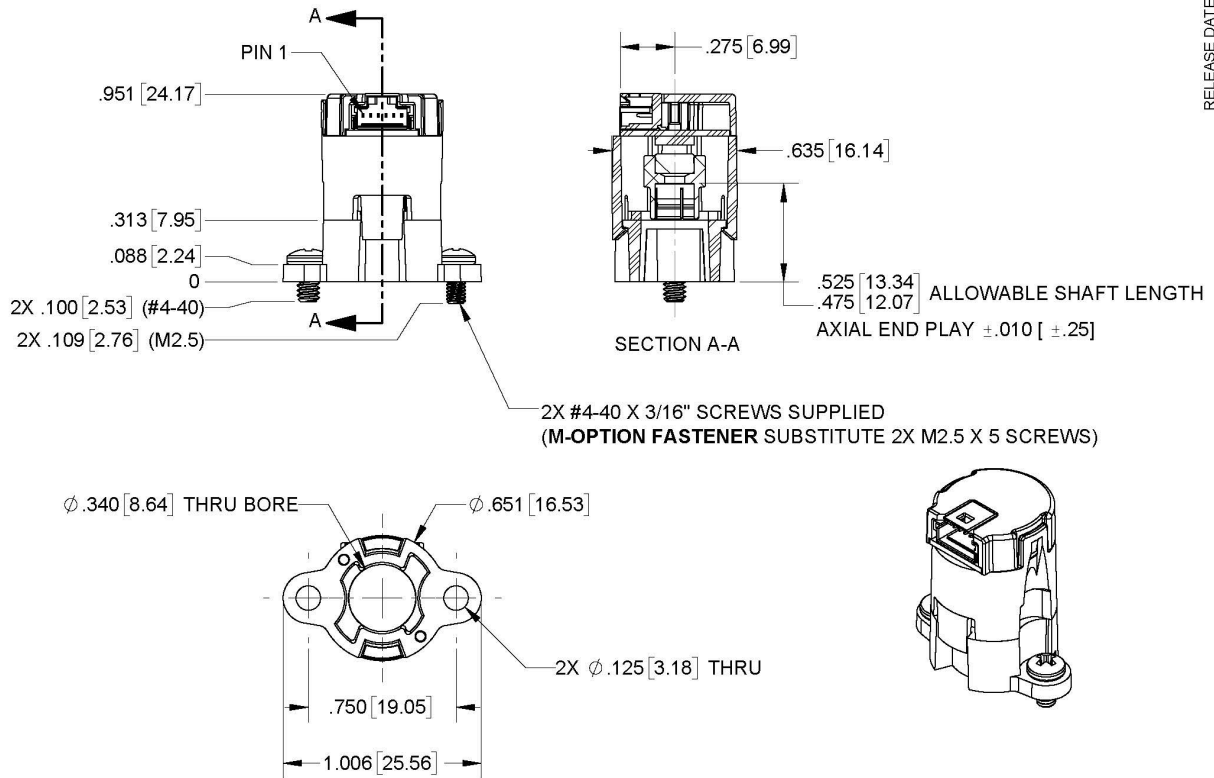

US DIGITAL 1400 NE 136th Avenue
Vancouver, Washington 98684, USA

info@usdigital.com
www.usdigital.com

Local: 360.260.2468
Toll-free: 800.736.0194

UNITS: INCHES [MM]
METRIC SHOWN FOR REFERENCE ONLY

Specifications

ENVIRONMENTAL

PARAMETER	VALUE	UNITS
Operating Temperature	-40 to 100	C
Electrostatic Discharge, IEC 61000-4-2	±1	kV
Shock, 6 millisecond, half-sine	75	G
Vibration (20Hz to 2kHz, sinusoidal)	20	G



MECHANICAL

PARAMETER	VALUE	UNITS
Shaft Length (1) 0.586" bolt circle (5-option) 0.750" bolt circle (7-option)	0.39 ± 0.035 0.5 ± 0.035	in.
Max. Shaft Axial Play	±0.010	in.
Max. Shaft Runout	0.004 T.I.R.	in.
Max. Acceleration	250,000	rad/sec ²
Max Hub Moment of Inertia	9.4 x 10 ⁻⁷	oz-in-s ²
Bolt Circle Diameter Tolerance	±0.005	in.
Mounting Screw Size 0.586 bolt circle (5-option) 0.750" bolt circle (7-option) Metric (M-option)	#3-48 x 3/16" #4-40 x 3/16" M2.5 x 5mm	
Mounting Screw Torque 0.586" bolt circle (5-option) 0.750" bolt circle (7-option) Metric (M-option)	2 to 3 4 to 6 2 to 3	in-lbs

(1) Including axial play.

Download (<https://www.usdigital.com/support/resources/reference/technical-docs/technical-bulletins/shaft-and-bore-tolerances-tb1001/>) **Technical Bulletin TB1001 - Shaft and Bore Tolerances**

ELECTRICAL



M3K Miniature Magnetic Incremental Kit Encoder

PARAMETER	MIN.	TYP.	MAX.	UNITS	NOTES
Supply Voltage	4.0	5.0	16.5	V	3.3V version available on request. Contact tech support.
Supply Current		17		mA	no load, 5V power
Low-level Output, A/B/Index		0.02	0.4	V	I _{OL} = 4mA no load
High-level Output, A/B/Index	4.0	4.8		V	I _{OL} = -4mA no load
Low-level Output, PWM		0.2	0.5	V	I _{OL} = 0.5mA no load
High-level Output, PWM		4.9	2.5	V	I _{OL} = -0.5mA no load
Output Rise/Fall Time, A/B/Index		25		nS	no load
Output Rise Time, PWM		1		μS	no load
Output Fall Time, PWM		25		nS	no load
12-bit PWM Frequency		2.0		kHz	Values up to 3.125 kHz available on request. Contact tech support.
PWM Duty Cycle range for 360 deg rotation	5		95	%	

- Typical values are specified at V_{cc} = 5.0V and 25C.
- A/B/Index outputs remain at 5V logic levels for V_{cc} > 5.0V
- PWM output is open-drain with 5k pullup to V_{cc}. The output is clamp limited to 6.5V Typ. for V_{cc} >5.0V



CPR	Max RPM (1)	Typical Count Jitter $\pm 2\sigma$ limits x4 quadrature decoding	Typical Angle Jitter $\pm 2\sigma$ limits x4 quadrature decoding
1	18720	0 counts	0 deg.
2	18720	0	0
4	18720	0	0
8	18720	0	0
16	18720	0	0
32	18720	0	0
64	18720	0	0
128	18720	0	0
256	18720	0	0
512	14648	± 1	± 0.18
1024	7324	± 1.4	± 0.12
2048	3662	± 1.4	± 0.062
4096	1831	± 2.1	± 0.05
8192	915	± 3.3	± 0.04

(1) minimum of 50 position samples per revolution

TIMING CHARACTERISTICS



PARAMETER	SYMBOL	MIN.	TYP.	MAX.	UNITS
Symmetry	X, Y		180		°e <i>(https://www.usdigital.com/support/resources/glossary/#glossary_e)</i>
Quadrature	Z		90		°e <i>(https://www.usdigital.com/support/resources/glossary/#glossary_e)</i>
Index Pulse Width	Po		90		°e <i>(https://www.usdigital.com/support/resources/glossary/#glossary_e)</i>
Ch. I Rise After Ch. B or Ch. A Fall	t1		10		ns
Ch. I Fall After Ch. B or Ch. A Rise	t2		10		ns

TIMING DIAGRAM

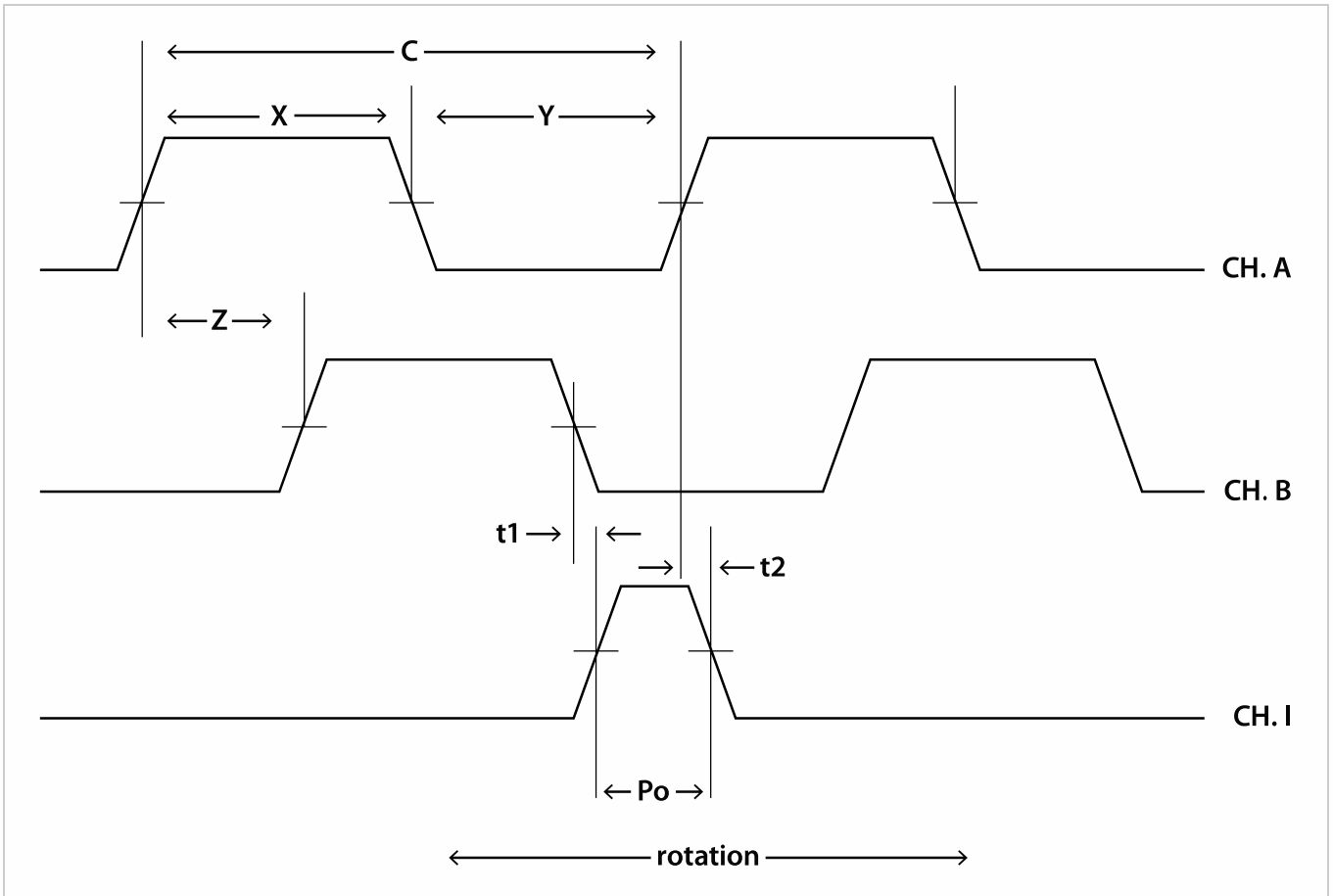

CPR

The number of Cycles (C) of the A or B outputs Per Revolution.

Index (I)

The index output goes high once per revolution, coincident with the low states of channels A and B, nominally 1/4 of one cycle (90°e).

One Shaft Rotation



M3K Miniature Magnetic Incremental Kit Encoder

360 mechanical degrees.

One Electrical Degree (°e)

1/360th of one cycle.

One Cycle (C)

360 electrical degrees (°e). Each cycle can be decoded into 1, 2, or 4 states, referred to as x1, x2, or x4 resolution multiplication.

PPR

The number of resolvable Positions Per Revolution of the encoder disk with x4 quadrature decoding.

Quadrature (Z)

The phase lag or lead between channels A and B in electrical degrees, nominally 90°e.

Symmetry

A measure of the relationship between (X) and (Y) in electrical degrees, nominally 180°e.

PIN-OUTS

PIN	DESCRIPTION
1	Ground
2	Index
3	B channel
4	+4~16.5VDC power
5	A channel
6	PWM



INCLUDED ACCESSORIES

1. CENTERING TOOL*

Part #: CTOOL - M3K - (Shaft Diameter)

Description: This reusable tool is used to accurately center the **M3K** base on the shaft.

2. SCREWS

Part #: SCREW-348-188-PH

Description: Pan Head, Philips #3-48 UNC x 3/16"

Use: Base Mounting

Quantity Required: 2

Screws are included

Part #: SCREW-440-118-PH

Description: Pan Head, Philips #4-40 UNC x 3/16"

Use: Base Mounting

Quantity Required: 2

Screws are included

Part #: SCREW-M25-5MM-PH

Description: Pan Head, Philips, M2.5 x 0.45 x 5MM

Use: Base Mounting

Quantity Required: 2

Screws are included

Notes

- US Digital® warrants its products against defects in materials and workmanship for two years. See complete warranty (<https://www.usdigital.com/company/warranty>) for details.