

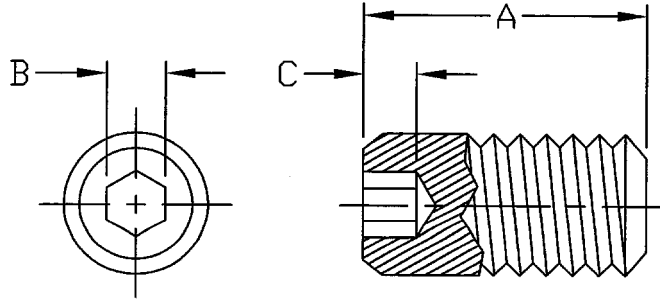

1. PART NUMBER AND CHARACTERISTICS



SEE ALSO 519113

TE Part No	Rev	Thread	A	B	C
519011-1	B	M1.6	2.5	.7	.7
519011-2	B	M1.6	3	.7	1.5
519011-3	B	M1.6	4	.7	1.5
519011-4	B	M1.6	5	.7	1.5
519011-5	B	M1.6	6	.7	1.5
519011-6	B	M2	3	.9	.8
519011-7	B	M2	4	.9	1.7
519011-8	B	M2	5	.9	1.7
519011-9	B	M2	6	.9	1.7
1-519011-0	B	M2	8	.9	1.7
1-519011-1	B	M2	10	.9	1.7
1-519011-2	B	M2.5	3	1.3	1.2
1-519011-3	B	M2.5	4	1.3	2
1-519011-4	B	M2.5	5	1.3	2
1-519011-5	B	M2.5	6	1.3	2
1-519011-6	B	M2.5	8	1.3	2
1-519011-7	B	M2.5	10	1.3	2
1-519011-8	B	M3	3	1.5	1.2
1-519011-9	B	M3	4	1.5	1.2
2-519011-0	B	M3	5	1.5	2
2-519011-1	B	M3	6	1.5	2
2-519011-2	B	M3	8	1.5	2
2-519011-3	B	M3	10	1.5	2
2-519011-4	B	M3	12	1.5	2
2-519011-5	B	M3	16	1.5	2

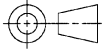
<b>COMMERCIALLY PURCHASED PRODUCT SPECIFICATION</b>				LOC <b>B</b>	MATERIAL Steel (45H)	FINISH Electroplated nickel	
							©2012 Tyco Electronics Corporation, a TE Connectivity Ltd. company All Rights Reserved
				DIMENSIONS IN mm	TITLE <b>SCREW, SET, SOCKET, FLAT POINT</b>		
							
E	Add additional drawing note	JNB	24JUL12	SHEET 1 OF 3	NO	<b>519011</b>	REV <b>E</b>
REV	ENGINEERING CHANGE	CHK	DATE				

1. PART NUMBER AND CHARACTERISTICS (Continued)

TE Part No	Rev	Thread	A	B	C
2-519011-6	B	M3	20	1.5	2
2-519011-7	B	M3	4	1.5	2
2-519011-8	B	M4	5	2	1.5
2-519011-9	B	M4	6	2	2.5
3-519011-0	B	M4	8	2	2.5
3-519011-1	B	M4	10	2	2.5
3-519011-2	B	M4	12	2	2.5
3-519011-3	B	M4	16	2	2.5
3-519011-4	B	M4	20	2	2.5
3-519011-5	B	M5	5	2.5	2
3-519011-6	B	M5	6	2.5	2
3-519011-7	B	M5	8	2.5	3
3-519011-8	B	M5	10	2.5	3
3-519011-9	B	M5	12	2.5	3
4-519011-0	B	M5	16	2.5	3
4-519011-1	B	M5	20	2.5	3
4-519011-2	B	M5	25	2.5	3
4-519011-3	B	M6	6	3	2
4-519011-4	B	M6	8	3	3.5
4-519011-5	B	M6	10	3	3.5
4-519011-6	B	M6	12	3	3.5
4-519011-7	B	M6	16	3	3.5
4-519011-8	B	M6	20	3	3.5
4-519011-9	B	M6	25	3	3.5
5-519011-0	B	M6	30	3	3.5
5-519011-1	B	M6	35	3	3.5
5-519011-2	B	M8	8	4	5
5-519011-3	B	M8	10	4	5
5-519011-4	B	M8	12	4	5
5-519011-5	B	M8	16	4	5
5-519011-6	B	M8	20	4	5
5-519011-7	B	M8	25	4	5
5-519011-8	B	M8	30	4	5
5-519011-9	B	M8	35	4	5
6-519011-0	B	M8	40	4	5
6-519011-1	B	M10	10	5	6
6-519011-2	B	M10	12	5	6
6-519011-3	B	M10	16	5	6
6-519011-4	B	M10	20	5	6
6-519011-5	B	M10	25	5	6
6-519011-6	B	M10	30	5	6
6-519011-7	B	M10	35	5	6
6-519011-8	B	M10	40	5	6
6-519011-9	B	M12	16	6	8
7-519011-0	B	M12	20	6	8



1. PART NUMBER AND CHARACTERISTICS (Continued)

TE Part No	Rev	Thread	A	B	C
7-519011-1	B	M12	25	6	8
7-519011-2	B	M12	30	6	8
7-519011-3	B	M12	35	6	8
7-519011-4	B	M12	40	6	8
7-519011-5	B	M16	20	8	10
7-519011-6	B	M16	25	8	10
7-519011-7	B	M16	30	8	10
7-519011-8	B	M16	35	8	10
7-519011-9	B	M16	40	8	10
8-519011-0	B	M20	20	10	12
8-519011-1	B	M20	25	10	12
8-519011-2	B	M20	30	10	12
8-519011-3	B	M20	35	10	12
8-519011-4	B	M20	40	10	12
8-519011-5	B	M20	45	10	12
8-519011-6	B	M20	50	10	12
8-519011-7	B	M24	25	12	15
8-519011-8	B	M24	30	12	15
8-519011-9	B	M24	35	12	15
9-519011-0	B	M24	40	12	15
9-519011-1	B	M24	45	12	15
9-519011-2	B	M24	50	12	15
9-519011-3	B	M24	55	12	15
9-519011-4	B	M24	60	12	15
9-519011-5	B	M6	45	3	3.5
9-519011-6	B	M6	40	3	3.5
9-519011-7	B	M5	4	2.5	2
9-519011-8	B	M4	18	2	2.5
9-519011-9	D	M5	35	2.5	2

- 1.1. Shall comply with DIN 913 45H and ISO 4026
- 1.2. Hardness: Rockwell C45-53
- 2. MANUFACTURER  
None



Tyco Electronics Corporation,  
a TE Connectivity Ltd. company

SHEET  
3 OF 3

NO

**519011**

REV  
E