

THIS PRODUCT MANUFACTURED WITH LEAD-FREE PROCESSING

DO NOT SCALE FROM THIS PRINT

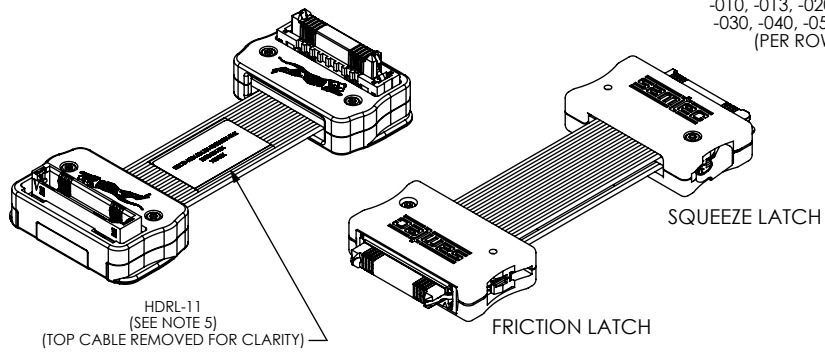

No OF POSITIONS
-010, -013, -020, -025, -030, -040, -050, -060
(PER ROW)

LENGTH
-XX.XX (INCHES)
(01.72[43.7] MIN)
(SEE NOTE 8)
(SEE NOTE 9)

FIRST END
-TTR: TERMINAL, TOP, RIGHT
-TTL: TERMINAL, TOP, LEFT
-TBR: TERMINAL, BOTTOM, RIGHT
-TBL: TERMINAL, BOTTOM, LEFT
-STR: SOCKET, TOP, RIGHT
-STL: SOCKET, TOP, LEFT
-SBR: SOCKET, BOTTOM, RIGHT
-SBL: SOCKET, BOTTOM, LEFT
-TEU: TERMINAL, EDMOUNT, UP
-TED: TERMINAL, EDMOUNT, DOWN

SECOND END
-TTR: TERMINAL, TOP, RIGHT
-TTL: TERMINAL, TOP, LEFT
-TBR: TERMINAL, BOTTOM, RIGHT
-TBL: TERMINAL, BOTTOM, LEFT
-STR: SOCKET, TOP, RIGHT
-STL: SOCKET, TOP, LEFT
-SBR: SOCKET, BOTTOM, RIGHT
-SBL: SOCKET, BOTTOM, LEFT
-TEU: TERMINAL, EDMOUNT, UP
-TED: TERMINAL, EDMOUNT, DOWN

LATCH OPTION** (SEE NOTE 12)
*L: 1ST END STD LATCH, 2ND END SQUEEZE LATCH
*R: 1ST END SQUEEZE LATCH, 2ND END STD LATCH
-D: BOTH ENDS STD LATCH
-N: NO CAPS (BOTH ENDS HAVE STD LATCH)
*B: BOTH ENDS SQUEEZE LATCH
*F: 1ST END SCREW OPTION, 2ND END FRICTION LATCH
-S: 1ST END FRICTION LATCH, 2ND END SCREW OPTION
-C: BOTH ENDS SCREW OPTION
***G: 1ST END SCREW OPTION, 2ND END SQUEEZE LATCH
***T: 1ST END SQUEEZE LATCH, 2ND END SCREW OPTION
*-1: BOTH ENDS EXTENDED HOUSING SQUEEZE LATCH
*-2: FIRST END FRICTION LATCH, 2ND END EXTENDED HOUSING SQUEEZE LATCH
*-3: FIRST END EXTENDED HOUSING SQUEEZE LATCH, 2ND END, FRICTION LATCH
***-4: FIRST END SCREW OPTION, 2ND END EXTENDED HOUSING SQUEEZE LATCH
***-5: FIRST END EXTENDED HOUSING SQUEEZE LATCH, 2ND END SCREW OPTION

WIRING OPTION
-1: PIN 1 TO PIN 1
-2: PIN 1 TO PIN 2
-3: PIN 1 TO PIN N-1
-4: PIN 1 TO PIN N
(SEE TABLE 7, SHEET 8)

*OPTION ONLY AVAILABLE WITH -TEX OPTIONS (SEE NOTE 10)
**LATCH OPTION REQUIRED, PART NUMBER MUST BE COMPLETE TO BE VALID
***SQUEEZE LATCH TEX OPTIONS ONLY

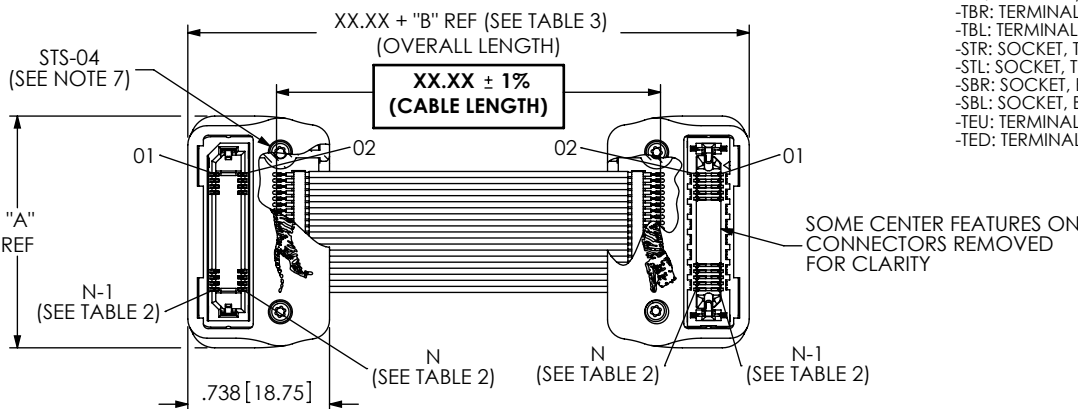
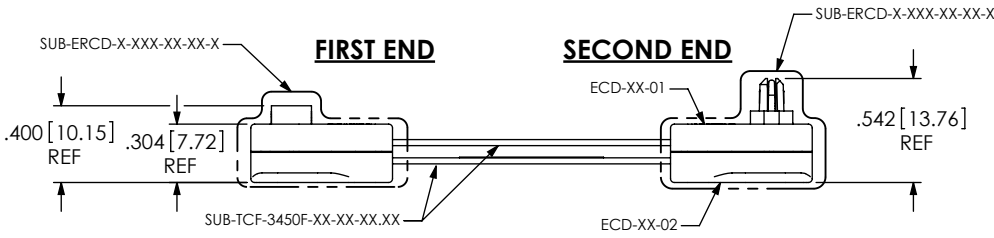

FIG 1
(ERCD-020-XX.XX-STL-TTR-1-D SHOWN)

END TO END	"B"
DV TO DV	.924[23.47]
DV TO EM (-TXX)	1.051[26.69]
EM (-TXX) TO EM (-TXX)	1.178[29.92]

- NOTES:
1. REPRESENTS A CRITICAL DIMENSION.
 2. PARTS TO BE PROCESSED PER SAMTEC ACCEPTABILITY REQUIREMENTS: HDR-PI-01 "CABLE ASSEMBLY WORKMANSHIP STANDARDS".
 3. ALL ASSEMBLIES TO BE 100% ELECTRICALLY TESTED.
 4. ALL ASSEMBLIES TO BE 100% HI-POT TESTED AT 300V.
 5. LABEL TO BE CENTERED ON LOWER CABLE AS SHOWN. LABEL TO CONTAIN:
LINE 1 - PART NUMBER "ERCD-XXX-XX.XX-XXX-XXX-X-X"
LINE 2 - SHOP ORDER NUMBER "XXXXXX"
LINE 3 - DATE CODE "XXXXXX"
 6. FOR PACKAGING REQUIREMENTS REFERENCE PACKAGING STANDARDS.
 7. TIGHTEN STS-04 FASTENERS TO 1.4-1.7 IN-LBS (4 PLCS).
 8. SUB-TCF LENGTH IS EQUAL TO ERCD LENGTH.
 9. CABLE LENGTHS LONGER THAN 40.00 INCHES ARE NOT SUPPORTED BY S.I. TEST DATA.
 10. -B & -1 OPTION ONLY AVAILABLE WITH -TEX ON BOTH ENDS. -L, -2, -G & -4 OPTIONS ONLY AVAILABLE WITH -TEX ON 2ND END. -R, -3, -T & -5 OPTION ONLY AVAILABLE WITH -TEX ON FIRST END.
 11. ASSEMBLY COMES STANDARD WITH SQUEEZE LATCH OR FRICTION LATCH OPTIONS. FOR OTHER REQUESTS PLEASE CALL SAMTEC.
 12. THE RECOMMENDED MATING CONNECTOR IS THE ERF8 OR ERM8 WITH -L LATCHING OPTION

# OF POSITIONS	N	N-1
-010	20	19
-013	26	25
-020	40	39
-025	50	49
-030	60	59
-040	80	79
-050	100	99
-060	120	119



# OF POSITIONS	"A"	XCD-XX-01	XCD-XX-02	SUB-TCF-3450F-XX-XX-XX-XX		SUB-ERCD-X-XXX-XX-XX-X (SEE TABLE 7)
				PART #	QTY	
-010	.892[22.66]	ECD-10-01	ECD-10-02	SUB-TCF-3450F-10-01-XX-XX	2	SUB-ERCD-X-010-XX-XX-X
-013	.987[25.06]	ECD-13-01	ECD-13-02	SUB-TCF-3450F-13-01-XX-XX	2	SUB-ERCD-X-013-XX-XX-X
-020	1.207[30.66]	ECD-20-01	ECD-20-02	SUB-TCF-3450F-20-01-XX-XX	2	SUB-ERCD-X-020-XX-XX-X
-025	1.364[34.65]	ECD-25-01	ECD-25-02	SUB-TCF-3450F-25-01-XX-XX	2	SUB-ERCD-X-025-XX-XX-X
-030	1.522[38.66]	ECD-30-01	ECD-30-02	SUB-TCF-3450F-30-01-XX-XX	2	SUB-ERCD-X-030-XX-XX-X
-040	1.837[46.66]	ECD-40-01	ECD-40-02	SUB-TCF-3450F-20-01-XX-XX	4	SUB-ERCD-X-040-XX-XX-X
-050	2.152[54.66]	ECD-50-01	ECD-50-02	SUB-TCF-3450F-25-01-XX-XX	4	SUB-ERCD-X-050-XX-XX-X
-060	2.467[62.66]	ECD-60-01	ECD-60-02	SUB-TCF-3450F-30-01-XX-XX	4	SUB-ERCD-X-060-XX-XX-X

TOLERANCES DO NOT APPLY TO REFERENCE DIMENSIONS. UNLESS OTHERWISE SPECIFIED, DIMENSIONS ARE IN INCHES. TOLERANCES ARE:
DECIMALS .XX: ± 0.1 [3]
.XXX: ± 0.05 [13]
.XXXX: ± 0.020 [051]
ANGLES 2°

PROPRIETARY NOTE
THIS DOCUMENT CONTAINS CONFIDENTIAL AND PROPRIETARY INFORMATION AND ALL DESIGN, MANUFACTURING, REPRODUCTION, USE, PATENT RIGHTS AND SALES RIGHTS ARE EXPRESSLY RESERVED BY SAMTEC, INC. THIS DOCUMENT SHALL NOT BE DISCLOSED, IN WHOLE OR PART, TO ANY UNAUTHORIZED PERSON OR ENTITY NOR REPRODUCED, TRANSFERRED OR INCORPORATED IN ANY OTHER PROJECT IN ANY MANNER WITHOUT THE EXPRESS WRITTEN CONSENT OF SAMTEC, INC.





520 PARK EAST BLVD, NEW ALBANY, IN 47150
PHONE: 812-944-6733 FAX: 812-948-5047
e-Mail info@SAMTEC.com code 55322

DO NOT SCALE DRAWING SHEET SCALE: 1:1

DESCRIPTION:
0.8MM EDGE RATE COAX CABLE ASSEMBLY
DWG. NO.
ERCD-XXX-XX.XX-XXX-XXX-X-X
BY: J. BORGELT 1/17/08 SHEET 1 OF 6

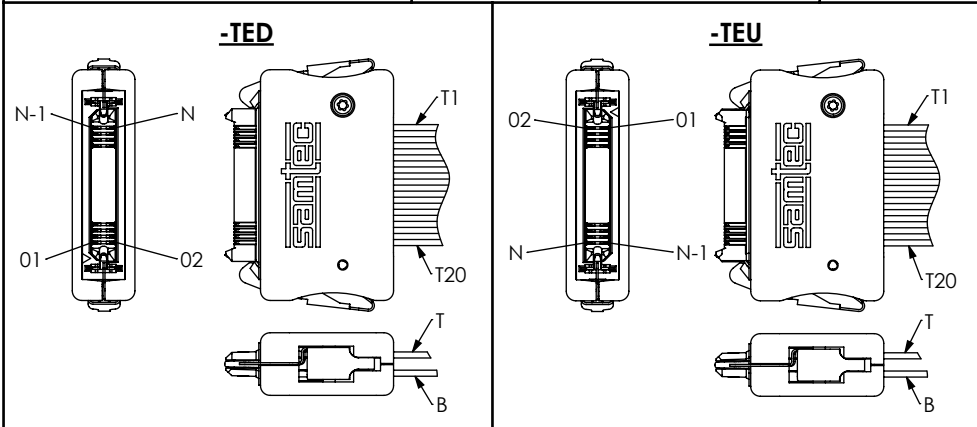
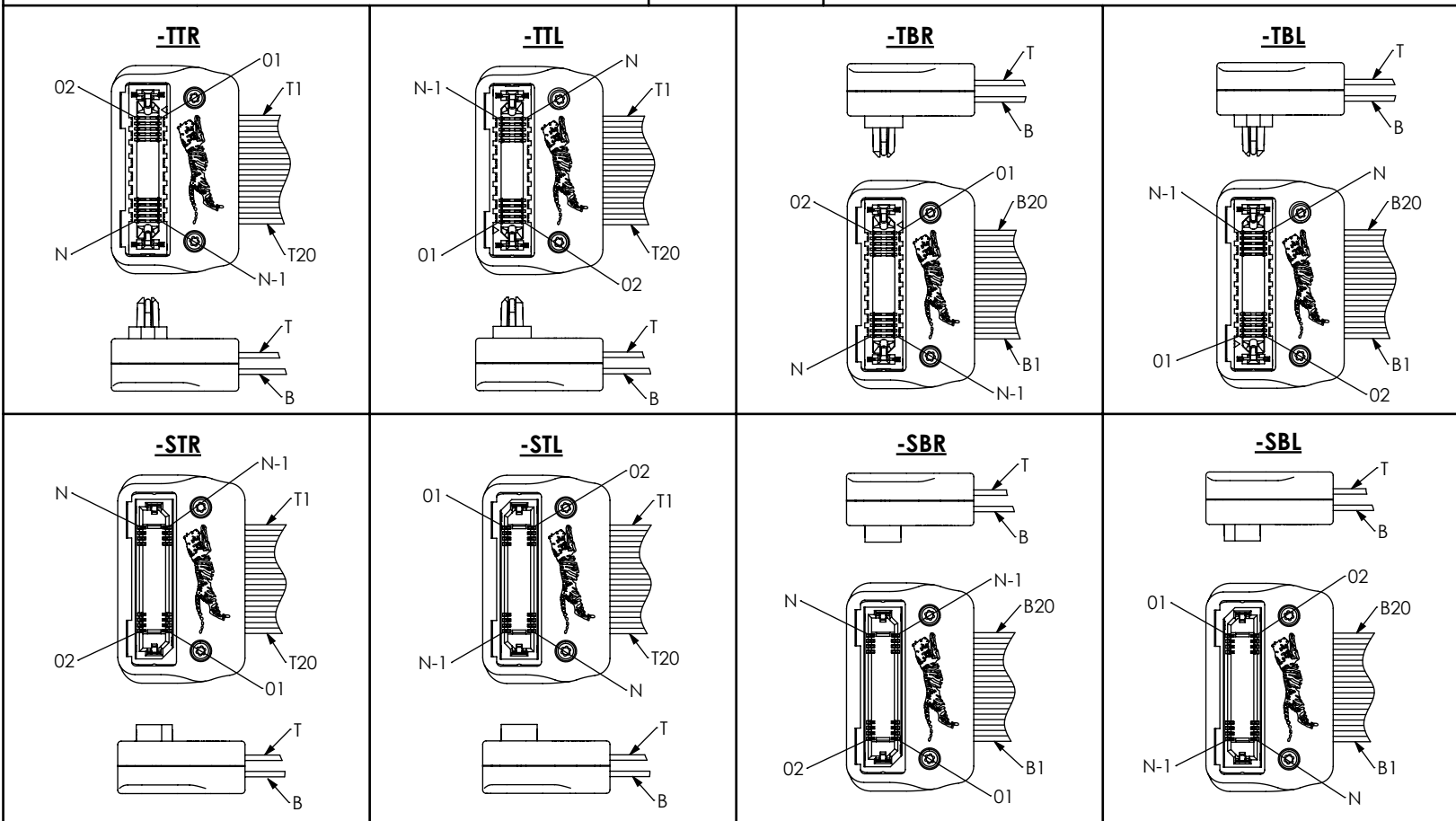
FIRST END



<p>PROPRIETARY NOTE</p> <p>THIS DOCUMENT CONTAINS CONFIDENTIAL AND PROPRIETARY INFORMATION AND ALL DESIGN, MANUFACTURING, REPRODUCTION, USE, PATENT RIGHTS AND SALES RIGHTS ARE EXPRESSLY RESERVED BY SAMTEC, INC. THIS DOCUMENT SHALL NOT BE DISCLOSED, IN WHOLE OR PART, TO ANY UNAUTHORIZED PERSON OR ENTITY NOR REPRODUCED, TRANSFERRED OR INCORPORATED IN ANY OTHER PROJECT IN ANY MANNER WITHOUT THE EXPRESS WRITTEN CONSENT OF SAMTEC, INC.</p>	 <p>520 PARK EAST BLVD., NEW ALBANY, IN 47150 PHONE: 812-944-6733 FAX: 812-948-5047 e-Mail: info@SAMTEC.com code 55322</p>	
	<p>DESCRIPTION: CUSTOM HDR CABLE ASSEMBLY</p>	
	<p>DWG. NO. ERCD-XXX-XX.XX-XXX-XXX-X-X</p>	
<p>DO NOT SCALE DRAWING</p>	<p>BY: J. BORGELT 1/17/08</p>	<p>SHEET 2 OF 6</p>

SECOND END

-TTR

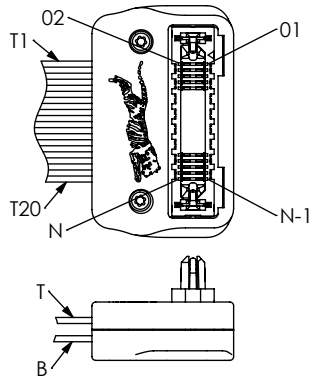

-TTL

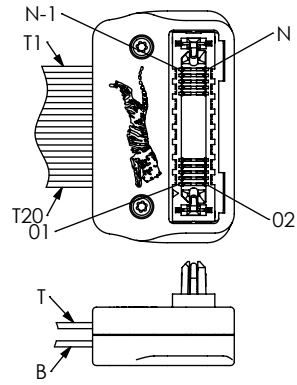

-TBR

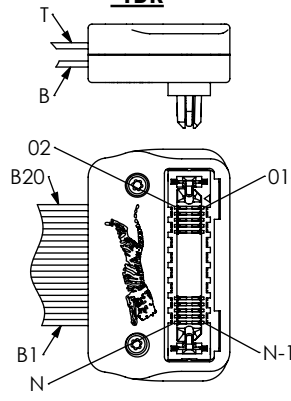

-TBL

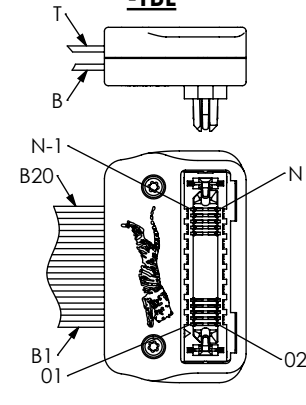

-STR

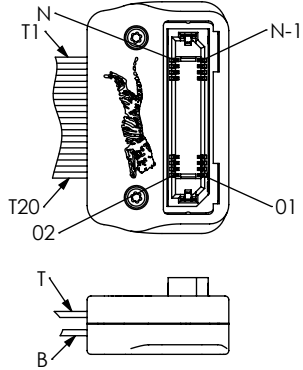

-STL

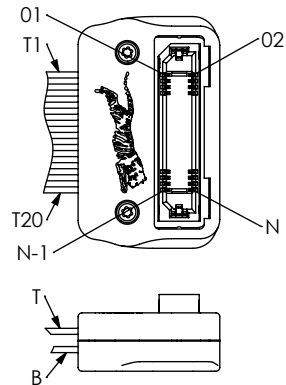

-SBR

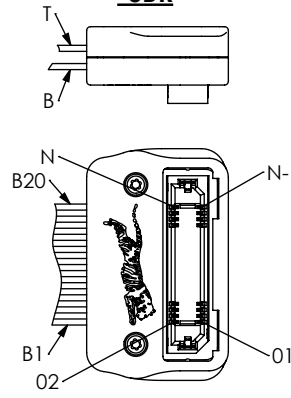

-SBL

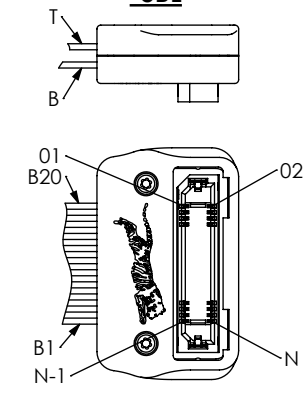

-TED

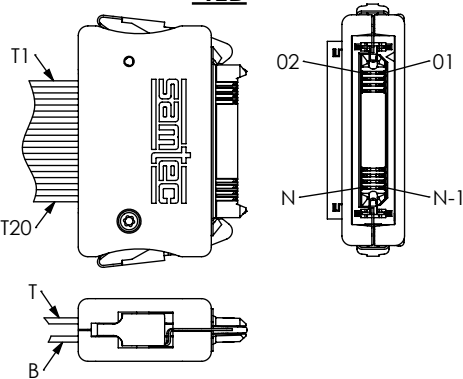

-TEU

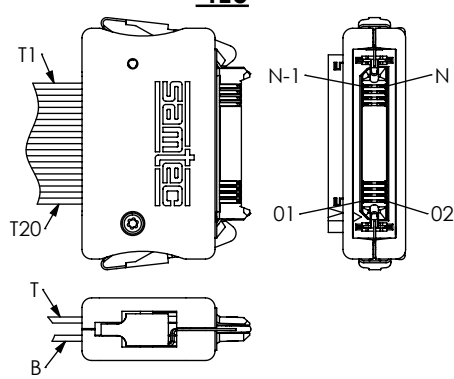

PROPRIETARY NOTE

THIS DOCUMENT CONTAINS CONFIDENTIAL AND PROPRIETARY INFORMATION AND ALL DESIGN, MANUFACTURING, REPRODUCTION, USE, PATENT RIGHTS AND SALES RIGHTS ARE EXPRESSLY RESERVED BY SAMTEC, INC. THIS DOCUMENT SHALL NOT BE DISCLOSED, IN WHOLE OR PART, TO ANY UNAUTHORIZED PERSON OR ENTITY NOR REPRODUCED, TRANSFERRED OR INCORPORATED IN ANY OTHER PROJECT IN ANY MANNER WITHOUT THE EXPRESS WRITTEN CONSENT OF SAMTEC, INC.



520 PARK EAST BLVD, NEW ALBANY, IN 47150
 PHONE: 812-944-6733 FAX: 812-948-5047
 e-Mail: info@SAMTEC.com code 55322

DO NOT SCALE DRAWING

DESCRIPTION: CUSTOM HDR CABLE ASSEMBLY

SHEET SCALE: 1:1

DWG. NO. ERCD-XXX-XX.XX-XXX-XXX-X-X

BY: J. BORGELT 1/17/08 SHEET 3 OF 6

FIG 2
(ERCD-020-XX.XX-TED-TEU-2-B SHOWN)

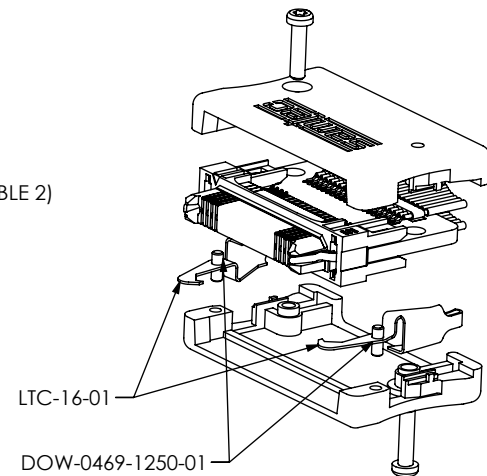
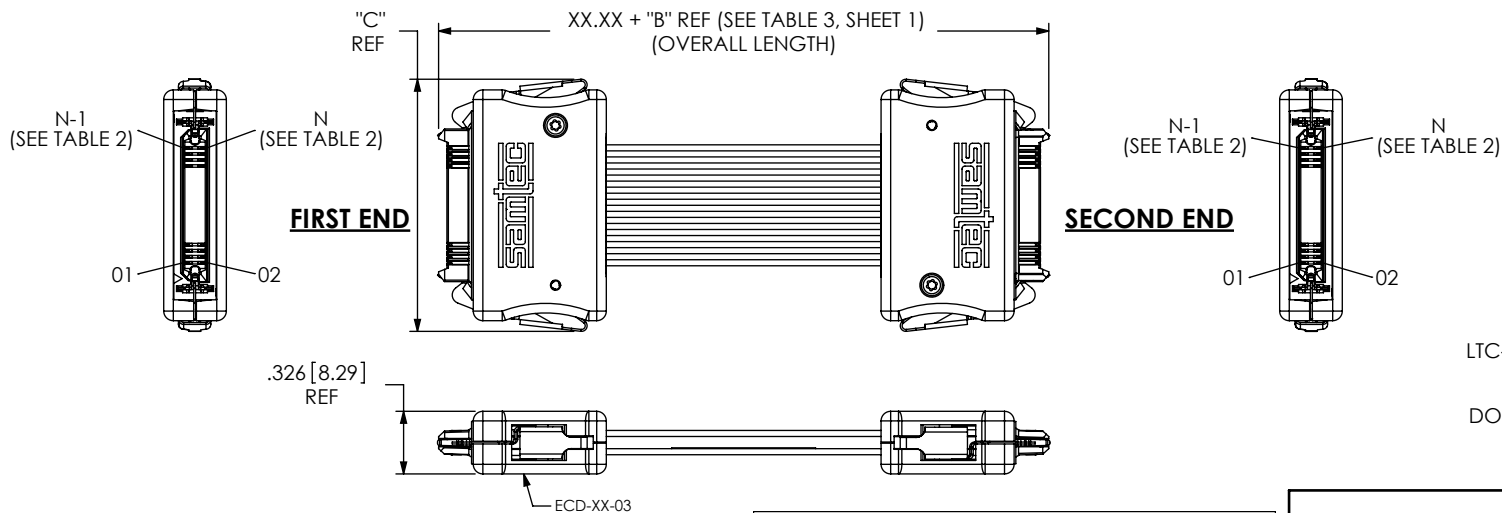

TABLE 4

# OF POSITIONS	"C"	XCD-XX-03	SUB-ERCD-X-XXX-03-XX-X (SEE TABLE 7 FOR PINOUT AVAILABILITY) (SEE TABLE 9 FOR LATCH CONFIG)
-010	.998 [25.36]	ECD-10-03	SUB-ERCD-X-010-03-XX-X
-013	1.092 [27.74]	ECD-13-03	SUB-ERCD-X-013-03-XX-X
-020	1.313 [33.36]	ECD-20-03	SUB-ERCD-X-020-03-XX-X
-025	1.470 [37.34]	ECD-25-03	SUB-ERCD-X-025-03-XX-X
-030	1.628 [41.36]	ECD-30-03	SUB-ERCD-X-030-03-XX-X
-040	1.943 [49.36]	ECD-40-03	SUB-ERCD-X-040-03-XX-X
-050	2.258 [57.36]	ECD-50-03	SUB-ERCD-X-050-03-XX-X
-060	2.573 [65.36]	ECD-60-03	SUB-ERCD-X-060-03-XX-X

TABLE 9

OPTION	SUB-XRCD-X-XXX-03-XX-X END 1	END 2	DOW-0469-1250-01 QUANTITY	LTC-16-01 QUANTITY	CPS-4-40-11-X QUANTITY
-L	-03-XX-L	-03-XX-B	2	2	0
-R	-03-XX-B	-03-XX-L	2	2	0
-D	-03-XX-L	-03-XX-L	0	0	0
-B	-03-XX-B	-03-XX-B	4	4	0
-N	-03-XX-L	-03-XX-L	0	0	0
-F	-03-XX-B	-03-XX-L	0	0	2
-S	-03-XX-L	-03-XX-B	0	0	2
-C	-03-XX-B	-03-XX-B	0	0	4
-G	-03-XX-B	-03-XX-B	2	2	2
-T	-03-XX-B	-03-XX-B	2	2	2

FIG 5
(ERCD-020-XX.XX-XXX-TEU-1-S SHOWN)

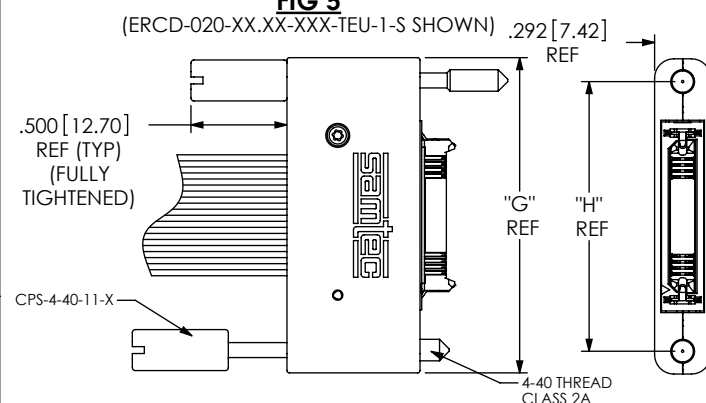

FIG 3
(ERCD-020-XX.XX-STL-TTR-1-N SHOWN)

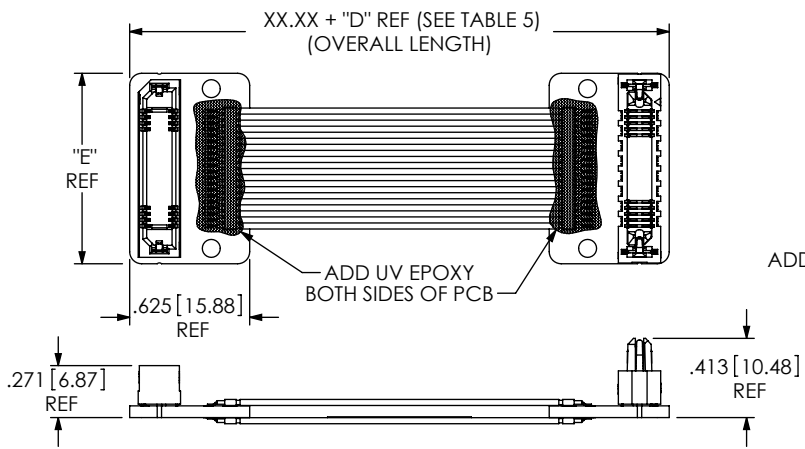

TABLE 5

END TO END	"D"
DV TO DV	.810 [20.57]
DV TO EM (-TXX)	.994 [25.24]
EM (-TXX) TO EM (-TXX)	1.178 [29.92]

FIG 4
(ERCD-020-XX.XX-XXX-TEU-1-N SHOWN)

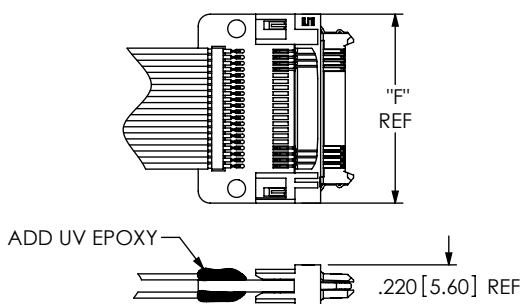

TABLE 6

# OF POSITIONS	"E"	"F"
-010	.677 [17.20]	.669 [16.99]
-013	.772 [19.61]	.764 [19.41]
-020	.992 [25.20]	0.984 [24.99]
-025	1.149 [29.18]	1.141 [28.98]
-030	1.307 [33.20]	1.299 [32.99]
-040	1.622 [41.20]	1.614 [40.99]
-050	1.937 [49.20]	1.929 [49.00]
-060	2.252 [57.20]	2.244 [57.00]

TABLE 10

# OF POSITIONS	"G"	"H"	XCD-XX-03-CPS
-010	1.3255 [33.6677]	1.0895 [27.6733]	ECD-10-03-CPS
-013	1.4200 [36.0680]	1.1840 [30.0736]	ECD-13-03-CPS
-020	1.6405 [41.6687]	1.4045 [35.6743]	ECD-20-03-CPS
-025	1.7980 [45.6692]	1.5620 [39.6748]	ECD-25-03-CPS
-030	1.9555 [49.6697]	1.7195 [43.6753]	ECD-30-03-CPS
-040	2.2705 [57.6707]	2.0345 [51.6763]	ECD-40-03-CPS
-050	2.5855 [65.6717]	2.3495 [59.6773]	ECD-50-03-CPS
-060	2.9005 [73.6727]	2.6645 [67.6783]	ECD-60-03-CPS

PROPRIETARY NOTE
THIS DOCUMENT CONTAINS CONFIDENTIAL AND PROPRIETARY INFORMATION AND ALL DESIGN, MANUFACTURING, REPRODUCTION, USE, PATENT RIGHTS AND SALES RIGHTS ARE EXPRESSLY RESERVED BY SAMTEC, INC. THIS DOCUMENT SHALL NOT BE DISCLOSED, IN WHOLE OR PART, TO ANY UNAUTHORIZED PERSON OR ENTITY NOR REPRODUCED, TRANSFERRED OR INCORPORATED IN ANY OTHER PROJECT IN ANY MANNER WITHOUT THE EXPRESS WRITTEN CONSENT OF SAMTEC, INC.



520 PARK EAST BLVD, NEW ALBANY, IN 47150
PHONE: 812-944-6733 FAX: 812-948-5047
e-Mail: info@SAMTEC.com code 55322

DO NOT SCALE DRAWING

DESCRIPTION: CUSTOM HDR CABLE ASSEMBLY

DWG. NO. **ERCD-XXX-XX.XX-XXX-XXX-X-X**

BY: J. BORGELT 1/17/08 SHEET 4 OF 6

SHEET SCALE: 1:1

FIG 6
ERCD-020-XX.XX-TEU-2-1 SHOWN

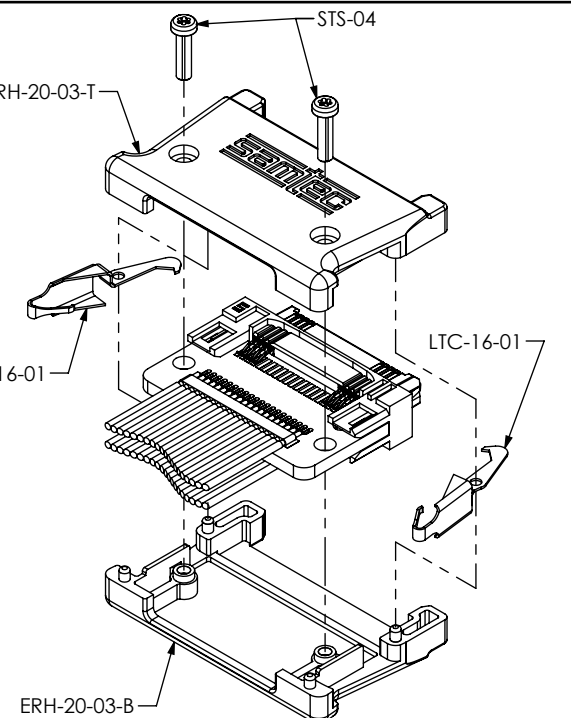
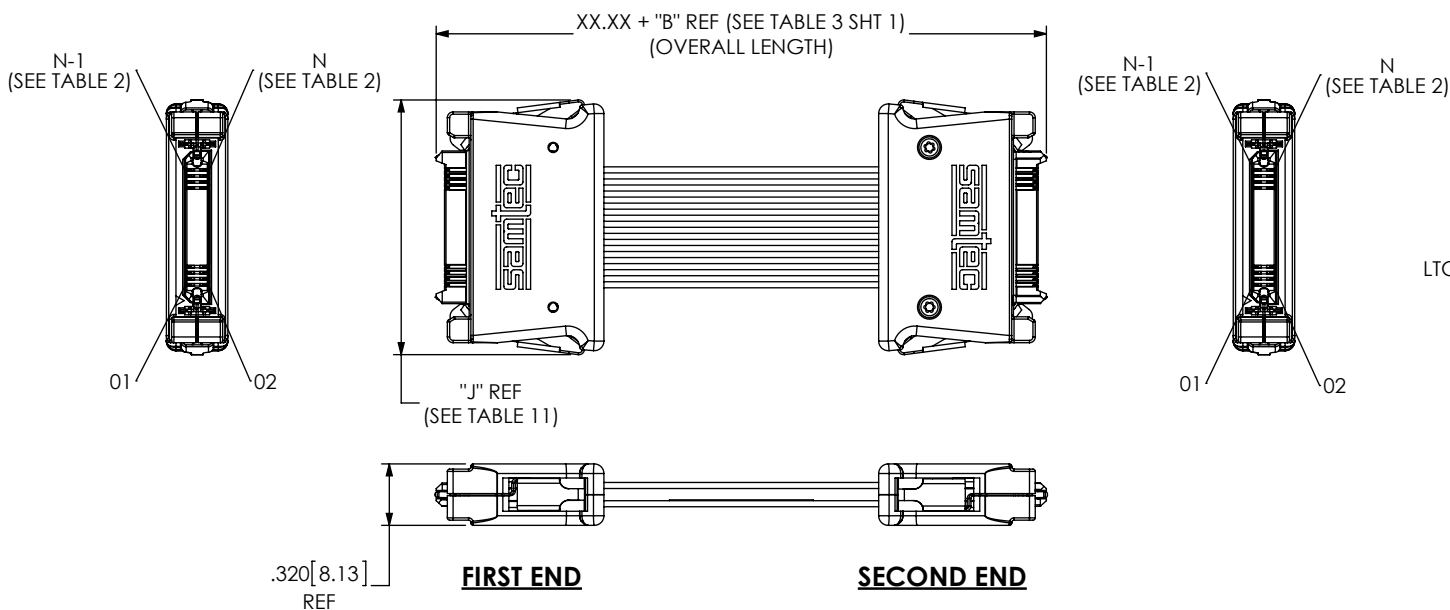
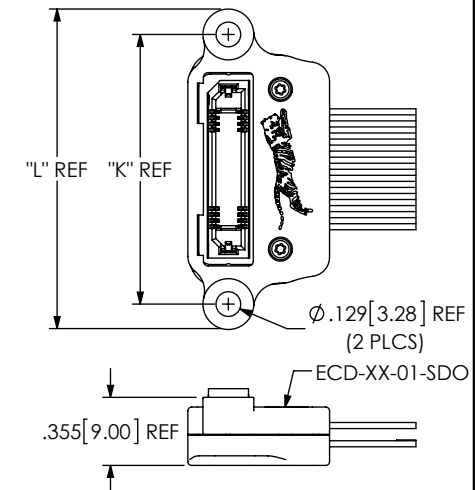

FIG 7
(ERCD-020-XX.XX-STL-XXX-1-F SHOWN)
(DIFFERENT AS SHOWN, OTHERWISE SAME AS FIG 1)



# OF POSITIONS	"J"	TOP HOUSING (PIN 1 SIDE)	BOTTOM HOUSING	SUB-ERCD-X-XXX-03-XX-X (SEE TABLE 7 FOR PINOUT AVAILABILITY) (SEE TABLE 12 FOR LATCH CONFIG)
-010	.969[24.63]	ERH-10-03-T	ERH-10-03-B	SUB-ERCD-X-010-03-XX-X
-013	1.064[27.03]	ERH-13-03-T	ERH-13-03-B	SUB-ERCD-X-013-03-XX-X
-020	1.284[32.64]	ERH-20-03-T	ERH-20-03-B	SUB-ERCD-X-020-03-XX-X
-025	1.442[36.64]	ERH-25-03-T	ERH-25-03-B	SUB-ERCD-X-025-03-XX-X
-030	1.599[40.64]	ERH-30-03-T	ERH-30-03-B	SUB-ERCD-X-030-03-XX-X
-040	1.914[48.64]	ERH-40-03-T	ERH-40-03-B	SUB-ERCD-X-040-03-XX-X
-050	2.229[56.64]	ERH-50-03-T	ERH-50-03-B	SUB-ERCD-X-050-03-XX-X
-060	2.544[64.64]	ERH-60-03-T	ERH-60-03-B	SUB-ERCD-X-060-03-XX-X

No OF POSITIONS	"K"	"L"	TOP HOUSING
-010	1.0895 [27.673]	1.355 [34.40]	ECD-10-01-SDO
-013	1.1840 [30.074]	1.449 [36.80]	ECD-13-01-SDO
-020	1.4045 [35.674]	1.670 [42.41]	ECD-20-01-SDO
-025	1.5620 [39.675]	1.827 [46.41]	ECD-25-01-SDO
-030	1.7195 [43.675]	1.985 [50.41]	ECD-30-01-SDO
-040	2.0345 [51.676]	2.300 [58.41]	ECD-40-01-SDO
-050	2.3495 [59.677]	2.615 [66.41]	ECD-50-01-SDO
-060	2.6645 [67.678]	2.930 [74.41]	ECD-60-01-SDO

LATCH OPTION	SUB-XRCD-X-XXX-03-XX-X		LTC-16-01	CPS-4-40-11-X
	END 1	END 2	QUANTITY	QUANTITY
-1	-03-XX-B	-03-XX-B	4	0
-2	-03-XX-L	-03-XX-B	2	0
-3	-03-XX-B	-03-XX-L	2	0
-4	-03-XX-B	-03-XX-B	2	2
-5	-03-XX-B	-03-XX-B	2	2

PROPRIETARY NOTE
THIS DOCUMENT CONTAINS CONFIDENTIAL AND PROPRIETARY INFORMATION AND ALL DESIGN, MANUFACTURING, REPRODUCTION, USE, PATENT RIGHTS AND SALES RIGHTS ARE EXPRESSLY RESERVED BY SAMTEC, INC. THIS DOCUMENT SHALL NOT BE DISCLOSED, IN WHOLE OR PART, TO ANY UNAUTHORIZED PERSON OR ENTITY NOR REPRODUCED, TRANSFERRED OR INCORPORATED IN ANY OTHER PROJECT IN ANY MANNER WITHOUT THE EXPRESS WRITTEN CONSENT OF SAMTEC, INC.

DO NOT SCALE DRAWING

SHEET SCALE: 1:2

samtec

520 PARK EAST BLVD, NEW ALBANY, IN 47150
PHONE: 812-944-6733 FAX: 812-948-5047
e-Mail: info@SAMTEC.com code 53322

DESCRIPTION:
0.8MM EDGE RATE COAX CABLE ASSEMBLY

DWG. NO.
ERCD-XXX-XX.XX-XXX-XXX-X-X

BY: J. BORGELT 1/17/08 SHEET 5 OF 6

		TABLE 7													
FIRST END OPTION	FIRST END SUB-ERCD-X-XXX-XX-01-X	WIRING OPTION	FIRST END PIN #	SECOND END PIN #	WIRE #	SECOND END OPTION (SUB-ERCD-X-XXX-XX-XX-X)									
						-TTR	-TTL	-TBR	-TBL	-STR	-STL	-SBR	-SBL	-TEU	-TED
-TTR	-T-XXX-01-01	1	1	1	T1	-T-XXX-02-02	N/A	N/A	-T-XXX-01-02	N/A	-S-XXX-01-01	-S-XXX-02-01	N/A	N/A	-T-XXX-03-02
		2	1	2	T1	-T-XXX-02-01	N/A	N/A	-T-XXX-01-01	N/A	-S-XXX-01-02	-S-XXX-02-02	N/A	N/A	-T-XXX-03-01
		3	1	N-1	T1	N/A	-T-XXX-01-01	-T-XXX-02-01	N/A	-S-XXX-02-02	N/A	N/A	-S-XXX-01-02	-T-XXX-03-01	N/A
		4	1	N	T1	N/A	-T-XXX-01-02	-T-XXX-02-02	N/A	-S-XXX-02-01	N/A	N/A	-S-XXX-01-01	-T-XXX-03-02	N/A
-TTL	-T-XXX-02-01	1	1	1	B20	N/A	-T-XXX-01-02	-T-XXX-02-02	N/A	-S-XXX-02-01	N/A	N/A	-S-XXX-01-01	-T-XXX-03-02	N/A
		2	1	2	B20	N/A	-T-XXX-01-01	-T-XXX-02-01	N/A	-S-XXX-02-02	N/A	N/A	-S-XXX-01-02	-T-XXX-03-01	N/A
		3	1	N-1	B20	-T-XXX-02-01	N/A	N/A	-T-XXX-01-01	N/A	-S-XXX-01-02	-S-XXX-02-02	N/A	N/A	-T-XXX-03-01
		4	1	N	B20	-T-XXX-02-02	N/A	N/A	-T-XXX-01-02	N/A	-S-XXX-01-01	-S-XXX-02-01	N/A	N/A	-T-XXX-03-02
-TBR	-T-XXX-01-01	1	1	1	B20	N/A	-T-XXX-01-02	-T-XXX-02-02	N/A	-S-XXX-02-01	N/A	N/A	-S-XXX-01-01	-T-XXX-03-02	N/A
		2	1	2	B20	N/A	-T-XXX-01-01	-T-XXX-02-01	N/A	-S-XXX-02-02	N/A	N/A	-S-XXX-01-02	-T-XXX-03-01	N/A
		3	1	N-1	B20	-T-XXX-02-01	N/A	N/A	-T-XXX-01-01	N/A	-S-XXX-01-02	-S-XXX-02-02	N/A	N/A	-T-XXX-03-01
		4	1	N	B20	-T-XXX-02-02	N/A	N/A	-T-XXX-01-02	N/A	-S-XXX-01-01	-S-XXX-02-01	N/A	N/A	-T-XXX-03-02
-TBL	-T-XXX-02-01	1	1	1	T1	-T-XXX-02-02	N/A	N/A	-T-XXX-01-02	N/A	-S-XXX-01-01	-S-XXX-02-01	N/A	N/A	-T-XXX-03-02
		2	1	2	T1	-T-XXX-02-01	N/A	N/A	-T-XXX-01-01	N/A	-S-XXX-01-02	-S-XXX-02-02	N/A	N/A	-T-XXX-03-01
		3	1	N-1	T1	N/A	-T-XXX-01-01	-T-XXX-02-01	N/A	-S-XXX-02-02	N/A	N/A	-S-XXX-01-02	-T-XXX-03-01	N/A
		4	1	N	T1	N/A	-T-XXX-01-02	-T-XXX-02-02	N/A	-S-XXX-02-01	N/A	N/A	-S-XXX-01-01	-T-XXX-03-02	N/A
-STR	-S-XXX-01-01	1	1	1	T20	N/A	-T-XXX-01-01	-T-XXX-02-01	N/A	-S-XXX-02-02	N/A	N/A	-S-XXX-01-02	-T-XXX-03-01	N/A
		2	1	2	T20	N/A	-T-XXX-01-02	-T-XXX-02-02	N/A	-S-XXX-02-01	N/A	N/A	-S-XXX-01-01	-T-XXX-03-02	N/A
		3	1	N-1	T20	-T-XXX-02-02	N/A	N/A	-T-XXX-01-02	N/A	-S-XXX-01-01	-S-XXX-02-01	N/A	N/A	-T-XXX-03-01
		4	1	N	T20	-T-XXX-02-01	N/A	N/A	-T-XXX-01-01	N/A	-S-XXX-01-02	-S-XXX-02-02	N/A	N/A	-T-XXX-03-02
-STL	-S-XXX-02-01	1	1	1	B1	-T-XXX-02-01	N/A	N/A	-T-XXX-01-01	N/A	-S-XXX-01-02	-S-XXX-02-02	N/A	N/A	-T-XXX-03-01
		2	1	2	B1	-T-XXX-02-02	N/A	N/A	-T-XXX-01-02	N/A	-S-XXX-01-01	-S-XXX-02-01	N/A	N/A	-T-XXX-03-02
		3	1	N-1	B1	N/A	-T-XXX-01-02	-T-XXX-02-02	N/A	-S-XXX-02-01	N/A	N/A	-S-XXX-01-01	-T-XXX-03-01	N/A
		4	1	N	B1	N/A	-T-XXX-01-01	-T-XXX-02-01	N/A	-S-XXX-02-02	N/A	N/A	-S-XXX-01-02	-T-XXX-03-02	N/A
-SBR	-S-XXX-01-01	1	1	1	B1	-T-XXX-02-01	N/A	N/A	-T-XXX-01-01	N/A	-S-XXX-01-02	-S-XXX-02-02	N/A	N/A	-T-XXX-03-01
		2	1	2	B1	-T-XXX-02-02	N/A	N/A	-T-XXX-01-02	N/A	-S-XXX-01-01	-S-XXX-02-01	N/A	N/A	-T-XXX-03-02
		3	1	N-1	B1	N/A	-T-XXX-01-02	-T-XXX-02-02	N/A	-S-XXX-02-01	N/A	N/A	-S-XXX-01-01	-T-XXX-03-01	N/A
		4	1	N	B1	N/A	-T-XXX-01-01	-T-XXX-02-01	N/A	-S-XXX-02-02	N/A	N/A	-S-XXX-01-02	-T-XXX-03-02	N/A
-SBL	-S-XXX-02-01	1	1	1	T20	N/A	-T-XXX-01-01	-T-XXX-02-01	N/A	-S-XXX-02-02	N/A	N/A	-S-XXX-01-02	-T-XXX-03-01	N/A
		2	1	2	T20	N/A	-T-XXX-01-02	-T-XXX-02-02	N/A	-S-XXX-02-01	N/A	N/A	-S-XXX-01-01	-T-XXX-03-02	N/A
		3	1	N-1	T20	-T-XXX-02-02	N/A	N/A	-T-XXX-01-02	N/A	-S-XXX-01-01	-S-XXX-02-01	N/A	N/A	-T-XXX-03-01
		4	1	N	T20	-T-XXX-02-01	N/A	N/A	-T-XXX-01-01	N/A	-S-XXX-01-02	-S-XXX-02-02	N/A	N/A	-T-XXX-03-02
-TEU	-T-XXX-03-01	1	1	1	T1	-T-XXX-02-02	N/A	N/A	-T-XXX-01-02	N/A	-S-XXX-01-01	-S-XXX-02-01	N/A	N/A	-T-XXX-03-02
		2	1	2	T1	-T-XXX-02-01	N/A	N/A	-T-XXX-01-01	N/A	-S-XXX-01-02	-S-XXX-02-02	N/A	N/A	-T-XXX-03-01
		3	1	N-1	T1	N/A	-T-XXX-01-01	-T-XXX-02-01	N/A	-S-XXX-02-02	N/A	N/A	-S-XXX-01-02	-T-XXX-03-01	N/A
		4	1	N	T1	N/A	-T-XXX-01-02	-T-XXX-02-02	N/A	-S-XXX-02-01	N/A	N/A	-S-XXX-01-01	-T-XXX-03-02	N/A
-TED	-T-XXX-03-01	1	1	1	B20	N/A	-T-XXX-01-02	-T-XXX-02-02	N/A	-S-XXX-02-01	N/A	N/A	-S-XXX-01-01	-T-XXX-03-02	N/A
		2	1	2	B20	N/A	-T-XXX-01-01	-T-XXX-02-01	N/A	-S-XXX-02-02	N/A	N/A	-S-XXX-01-02	-T-XXX-03-01	N/A
		3	1	N-1	B20	-T-XXX-02-01	N/A	N/A	-T-XXX-01-01	N/A	-S-XXX-01-02	-S-XXX-02-02	N/A	N/A	-T-XXX-03-01
		4	1	N	B20	-T-XXX-02-02	N/A	N/A	-T-XXX-01-02	N/A	-S-XXX-01-01	-S-XXX-02-01	N/A	N/A	-T-XXX-03-02

TABLE 8						
SIGNAL MAP						
POSITION	1	3	5	7	...	N-1
SIGNAL	S	S	S	S	...	S
SIGNAL	S	S	S	S	...	S
POSITION	2	4	6	8	...	N

NOTE: CONNECTOR LATCHES ARE GROUND
SQUEEZE LATCHES ARE NOT GROUND

<p>PROPRIETARY NOTE</p> <p>THIS DOCUMENT CONTAINS CONFIDENTIAL AND PROPRIETARY INFORMATION AND ALL DESIGN, MANUFACTURING, REPRODUCTION, USE, PATENT RIGHTS AND SALES RIGHTS ARE EXPRESSLY RESERVED BY SAMTEC, INC. THIS DOCUMENT SHALL NOT BE DISCLOSED, IN WHOLE OR PART, TO ANY UNAUTHORIZED PERSON OR ENTITY NOR REPRODUCED, TRANSFERRED OR INCORPORATED IN ANY OTHER PROJECT IN ANY MANNER WITHOUT THE EXPRESS WRITTEN CONSENT OF SAMTEC, INC.</p>	 <p>520 PARK EAST BLVD. NEW ALBANY, IN 47150 PHONE: 812-944-6733 FAX: 812-948-5047 e-Mail: info@SAMTEC.com code 55322</p>	
	<p>DO NOT SCALE DRAWING</p>	
	<p>DESCRIPTION: CUSTOM HDR CABLE ASSEMBLY</p> <p>DWG. NO. ERCD-XXX-XX.XX-XXX-XXX-X-X</p> <p>BY: J. BORGELT 1/17/08 SHEET 6 OF 6</p>	