



Introduction

The ST1S06 is an adjustable current mode pulse width modulation (PWM) synchronous, step down DC-DC converter with inhibit function. It is optimized for powering all low-voltage applications and, generally, to replace the high current linear solution when the power dissipation may cause overheating of the application environment.

It provides up to 1.5 A over an input voltage range of 2.5 V to 5.5 V. A high switching frequency (1.5 MHz) enables the use of tiny surface-mount components (SMD). In addition to the resistor divider used to set the output voltage value, only an inductor and two capacitors are required. Moreover, low output ripple is guaranteed by the current mode PWM topology and by the use of low series resistance (ESR) SMD ceramic capacitors.

The device is thermal protected and current limited to prevent damage due to accidental short circuits. It is a complete 1.5 A switching regulator with its internal compensation eliminating the need for additional components. The constant frequency, current mode, PWM architecture and stable operation with ceramic capacitors results in a low, predictable output ripple. To clamp the error amplifier reference voltage, this device includes a Soft Start control block generating a voltage ramp.

The ST1S06 is available in 6L-DFN 3x3 package

Moreover, an on-chip power on reset of $50 = 100 \mu\text{s}$ ensures correct performance when switching on the power supply. Other circuits fitted to the device protection are the Thermal Shut down block which turn-off the regulator when the junction temperature exceeds 150°C typically and the Cycle- by-cycle Current Limiting that provides protection against shorted outputs. Being the ST1S06 an adjustable regulator, the output voltage is determined by an external resistor divider. The desired value is given by the following equation:

Equation 1

$$V_{\text{OUT}} = V_{\text{FB}} \left[1 + \frac{R_1}{R_2} \right]$$

Due to the high switching frequency and peak current, it is important to optimize the application environment by reducing the length of the PCB traces and placing all the external component near the device. The chosen inductor must not saturate at the peak current level. Moreover, its value can be selected keeping in account that a large inductor value increases the efficiency at low output current and reduces output voltage ripple, while a smaller inductor can be chosen when it is important to reduce the package size and the total cost of the application.

Finally, the ST1S06 is designed to work properly with X5R or X7R SMD ceramic capacitors both at the input and at the output. These types of capacitors, thanks to their very low series resistance (ESR), minimize the output voltage ripple. Other low ESR capacitors values can be used depending on application requirements without invalidating correct device performance.

Contents

- 1 **Selecting components for your application** 4**
 - 1.1 Input capacitor 4
 - 1.2 Output capacitor 5
 - 1.3 Inductor 5

- 2 **Thermal considerations** 6**

- 3 **Short-circuit protection** 7**

- 4 **Board usage recommendation** 8**
 - 4.1 External component selection 9
 - 4.2 Inductor selection 9
 - 4.3 Capacitors selection 10

- 5 **Bill of materials** 11**

- 6 **Revision history** 11**

List of figures

Figure 1.	Simplified schematic	4
Figure 2.	ST1S06 board picture	8
Figure 3.	Board layer - top layer	8
Figure 4.	Board layer - bottom layer	8
Figure 5.	ST1S06 application schematic	9
Figure 6.	Efficiency vs. inductor	10
Figure 7.	Input voltage vs. output voltage	10
Figure 8.	Efficiency vs. output current	10
Figure 9.	Feedback voltage vs. temperature	10
Figure 10.	Inhibit voltage vs. input voltage	10
Figure 11.	Switching frequency vs. temperature	10

1 Selecting components for your application

This section provides information to help you select the best-adapted components for your application.

Figure 1. Simplified schematic

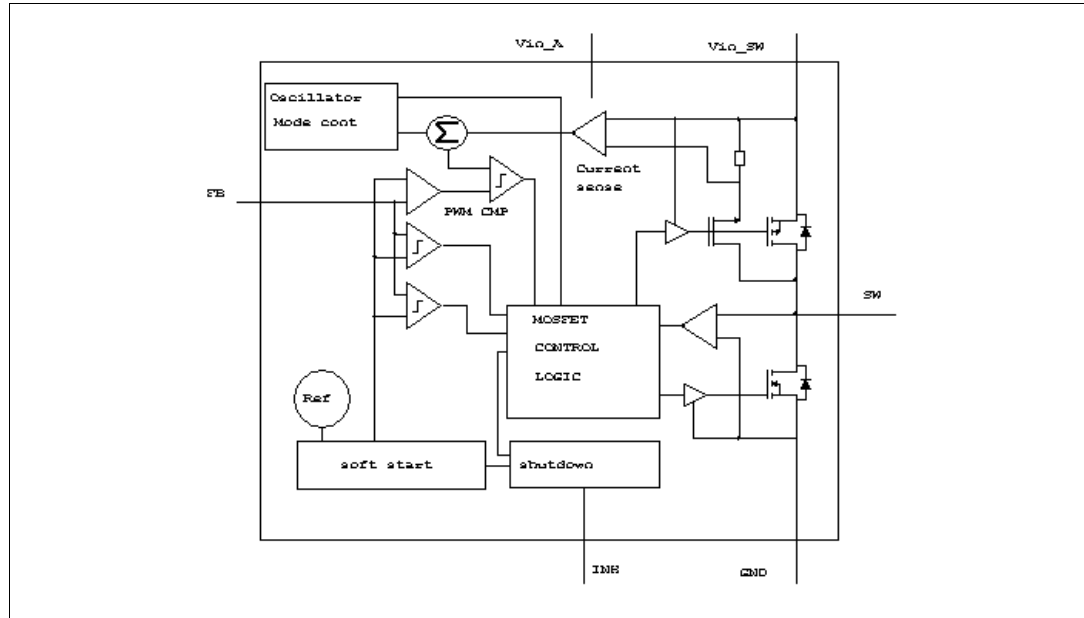

1.1 Input capacitor

The input capacitor must be able to support the maximum input operating voltage and the maximum RMS input current.

Since step-down converters draw current from the input in pulses, the input current is squared and the height of each pulse is equal to the output current. The input capacitor has to absorb all this switching current that can be up to the load current divided by two (worst case, with duty cycle of 50%).

For this reason, the quality of these capacitors must be very high to minimize the power dissipation generated by the internal ESR, thus improving system reliability and efficiency.

The critical parameter is usually the RMS current rating that has to be higher than the RMS input current. The maximum RMS input current (flowing through the input capacitor) is:

Equation 2

$$I_{RMS} = I_O \cdot \sqrt{D - \frac{2 \cdot D^2}{\eta} + \frac{D^2}{\eta}}$$

where η is the expected system efficiency, D is the duty cycle and I_O the output DC current. This function reaches its maximum value at $D = 0.5$ and the equivalent RMS current is equal to I_O divided by 2 (considering $\eta = 1$).

The maximum and minimum duty cycles are:

Equation 3

$$D_{MAX} = \frac{V_{OUT} + V_F}{V_{INMIN} - V_{SW}}$$

Equation 4

$$D_{MIN} = \frac{V_{OUT} + V_F}{V_{INMAX} - V_{SW}}$$

Where V_F is the voltage drop across the internal NMOS and V_{SW} the voltage drop across the internal PDMOS. Considering the range D_{MIN} to D_{MAX} , it is possible to determine the max I_{RMS} following through the input capacitor.

Different types of capacitors can be considered:

- Electrolytic Capacitors. These are the most used because they are the least expensive and are available with a wide range of RMS current ratings. The only drawback is that, considering a requested ripple current rating, they are physically larger than other capacitors.
- Ceramic Capacitors. If available for the requested value and voltage rating, these capacitors have usually a higher RMS current rating for a given physical dimension (due to the very low ESR). The drawback is the quite high cost.
- Tantalum Capacitor. Very good tantalum capacitors are coming available, with very low ESR and small size. The only problem is that they occasionally can burn if subjected to very high current during the charge. So, it is better to avoid using this type of capacitor for the input filter of the device. In fact, they can be subject to high surge currents when connected to the power supply.

1.2 Output capacitor

The output capacitor is very important to satisfy the output voltage ripple requirement. Using a small inductor value is useful to reduce the size of the choke but increases the current ripple. So, to reduce the output voltage ripple a low ESR capacitor is required.

1.3 Inductor

The inductor value is very important because it sets the ripple current flowing through output capacitor. The ripple current is usually set to 20-40% of I_{Omax} , that is 0.3-0.6 A with $I_{Omax} = 1.5$ A. The approximate inductor value is obtained by the following formula:

Equation 5

$$L = \frac{V_{IN} - V_{OUT}}{\Delta I} \cdot t_{ON}$$

Where t_{ON} is the ON time of the internal switch, given by $D \cdot T$.

For example, with $V_{OUT} = 3.3$ V, $V_{IN} = 5$ V and $\Delta I_O = 0.45$ A, the inductor value is about 2.8 μ H. The peak current through the inductor is given by:

Equation 6

$$I_{PK} = I_O + \frac{\Delta I}{2}$$

2 Thermal considerations

The dissipated power of the device is related to three different sources:

1. Switch losses due to the not negligible $R_{DS(on)}$. These are equal to:

Equation 7

$$P_{ON-P} = R_{DS(on)-P} \cdot I_{OUT}^2 \cdot D$$

Equation 8

$$P_{ON-P} = R_{DS(on)-P} \cdot I_{OUT}^2 \cdot (1 - D)$$

Where D is the duty cycle of the application. Note that the duty cycle is theoretically given by the ratio between V_{OUT} and V_{in} , but in practical is quite higher than this value to compensate the losses of the overall application. Due to this reason, the switch losses related to the $R_{DS(on)}$ increases compared with the ideal case.

2. Switch losses due to its turn-on and off. These are given by the following relation:

Equation 9

$$P_{SW} = V_{IN} \cdot I_{OUT} \cdot \frac{(t_{ON} + t_{OFF})}{2} \cdot F_{SW} = V_{IN} \cdot I_{OUT} \cdot t_{SW} \cdot F_{SW}$$

Where t_{ON} and t_{OFF} are the overlap times of the voltage across the power switch and the current flowing into it during the turn-on and turn-off phases. t_{SW} is the equivalent switching time.

3. Quiescent current losses

Equation 10

$$P_Q = V_{IN} \cdot I_Q$$

Where I_Q is the quiescent current. Example: $V_{IN} = 5$ V, $V_{OUT} = 3.3$ V, $I_{OUT} = 1.5$ A

$R_{DS(on)}$ has a typical value of 0.12Ω @ 25°C and increases up to a maximum value of 0.16Ω @ 150°C . We can consider a value of 0.15Ω t_{SW} is approximately 20 ns. I_Q has a typical value of 1.5 mA @ $V_{in} = 5$ V. The overall losses are:

Equation 11

$$\begin{aligned} P_{TOT} &= R_{DS(on)-P} \cdot I_{OUT}^2 \cdot D + R_{DS(on)-N} \cdot I_{OUT}^2 \cdot (1-D) + V_{IN} \cdot I_{OUT} \cdot t_{SW} \cdot F_{SW} + V_{IN} \cdot I_Q \\ &= 0.15 \cdot 1.5^2 \cdot 0.73 + 0.12 \cdot 1.5^2 \cdot (1-0.73) + 5 \cdot 1.5 \cdot 20 \cdot 10^{-9} \cdot 1.5 \cdot 10^6 + 5 \cdot 1.5 \cdot 10^{-3} \approx 0.552 \text{ W} \end{aligned}$$

The junction temperature of device will be:

Equation 12

$$T_J = T_A + R_{th_{J-A}} \cdot P_{TOT}$$

Where T_A is the ambient temperature and $R_{th_{J-A}}$ is the thermal resistance junction to ambient. Considering that the device is mounted on board with a good ground plane has a thermal resistance junction to ambient ($R_{th_{J-A}}$) of about 55°C/W and considering an ambient temperature of about 85°C .

Equation 13

$$T_J = 85 + 0.552 \cdot 55 = 115^\circ\text{C}$$

3 Short-circuit protection

In Over-current Protection mode, when the peak current reaches the current limit, the device reduces the t_{ON} to its minimum value. In these conditions, the duty cycle is strongly reduced and, in most of the applications, this is enough to limit the current to I_{LIM} .

In any event, in case of a heavy short-circuit at the output ($V_{OUT}=0$ V) and depending on the application conditions (V_{CC} value and parasitic effect of external components), the current peak could reach values higher than I_{LIM} . This can be understood considering the inductor current ripple during the ON and OFF phases:

- ON phase

Equation 14

$$\Delta I_L = \frac{(V_{IN} - V_{OUT} - DCR_L \cdot I)}{L} \cdot t_{ON}$$

- OFF phase

Equation 15

$$\Delta I_L = \frac{(V_D + V_{OUT} + DCR_L \cdot I)}{L} \cdot t_{OFF}$$

Where V_D is the voltage drop across the internal NDMOS and DCR_L is the series resistance of the inductor. In short-circuit conditions, V_{OUT} is negligible. So, during the t_{OFF} the voltage applied to the inductor is very small and it can be that the current ripple in this phase does not compensate for the current ripple during the t_{ON} . The maximum current peak can be easily measured through the inductor with $V_{OUT} = 0$ V (short-circuit) and $V_{CC}=V_{inmax}$.

In case the application has to sustain the short-circuit condition for a long time, the external components (mainly inductor and diode) must be selected based on this value.

4 Board usage recommendation

The board shown in [Figure 2](#), is provided with Kelvin connection, it means that for each pin you have two lines available; one used to supply or sink current and the other one used to perform the needed measurement.

Figure 2. ST1S06 board picture

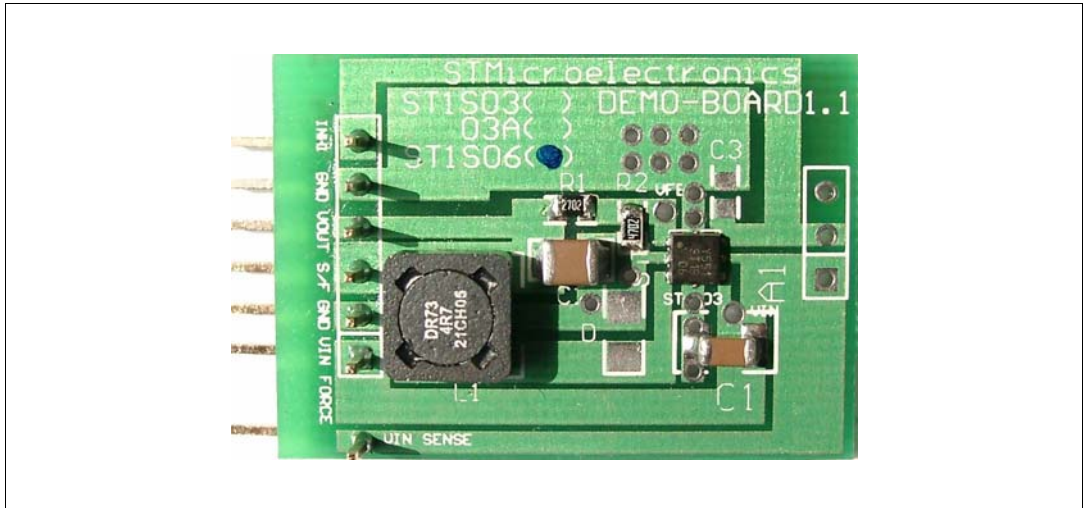

Figure 3. Board layer - top layer

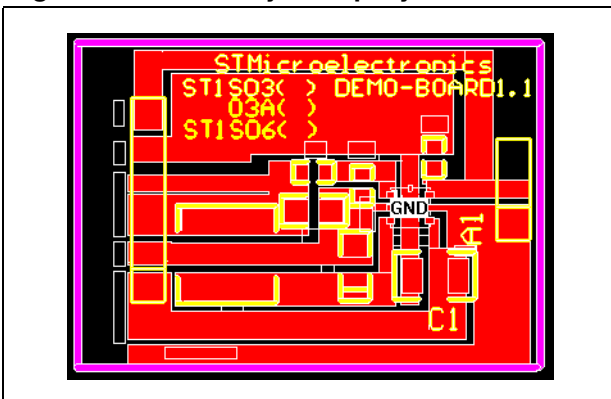
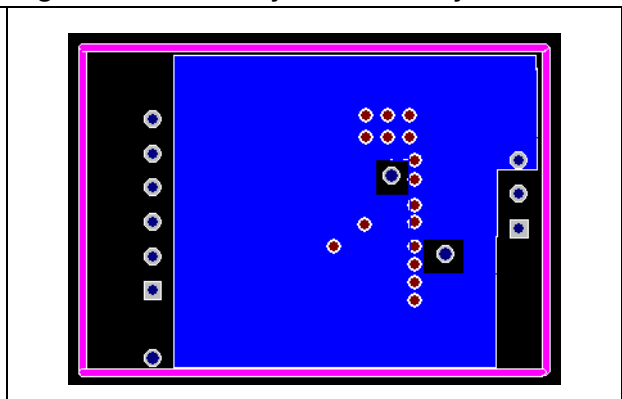

Figure 4. Board layer - bottom layer



The ST1S06 inhibit pin does not have an internal pull-up, meaning that you cannot leave the inhibit floating.

The board has available two inhibit pins. One is located on the right side of the board and can be connected to GND or VIN by a jumper in order to turn-off or on the device.

The other inhibit pin, located on the top left of the board, can be used to supply the inhibit pin with a voltage higher than 1.3 V to turn-on or lower than 0.4 V to turn-off the device.

4.1 External component selection

Figure 5 shows the typical application used to obtain an output voltage of 1.2 V.

Figure 5. ST1S06 application schematic

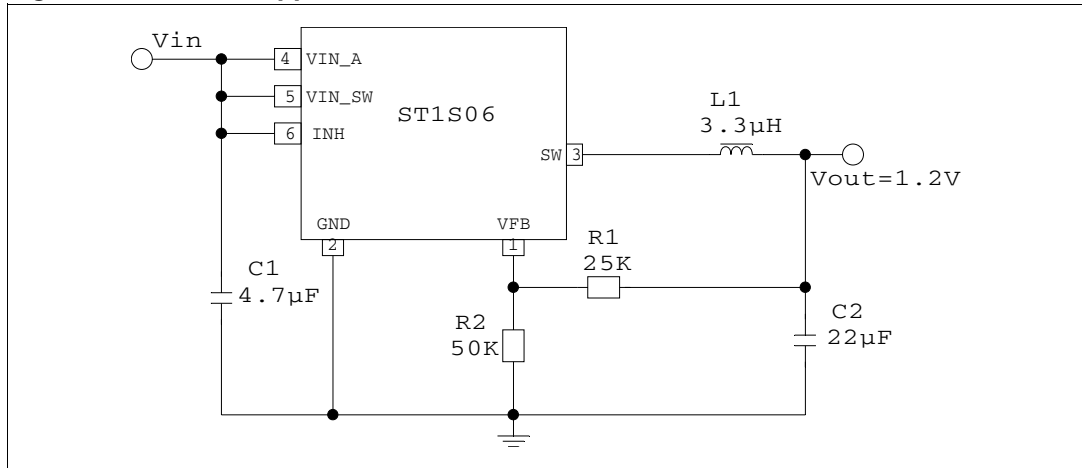

In order to obtain the needed output voltage, we must choose the resistor divider according to the following formula:

Equation 16

$$V_{OUT} = V_{FB} \cdot \left[1 + \frac{R_1}{R_2} \right]$$

with

$$V_{FB} = 0.8 \text{ V}$$

The resistor divider used in *Figure 5* represents a good compromise in terms of current consumption and minimum output voltage. For output voltages close to the feedback voltage, we suggest adding a very small capacitor in parallel with R_1 in the range of 10 pF. As an alternative, we suggest increasing the current in the resistor divider while decreasing the R_1 and R_2 values.

4.2 Inductor selection

Due to the high (1.5 MHz) frequency it is possible to use very small inductor values. In our board, we tested the device with an inductor in the 1 µH to 10 µH range with very good efficiency performance (see below).

As the device can provide an operative output current of 1.5 A, we strongly recommend using inductors able to manage at least 2.5 A.

4.3 Capacitors selection

It is possible to use any X5R or X7R ceramic capacitor

- C1 = 4.7 μ F (ceramic) or higher without limit
- C2 = 22 μ F (ceramic) or higher. It is possible to use several capacitors in parallel in order to reduce the equivalent series resistor and improve the ripple present in the output voltage.
- C3 is not used in the board.

Figure 6. Efficiency vs. inductor

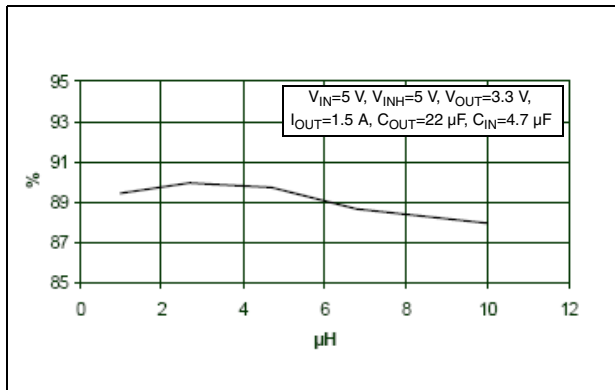

Figure 7. Input voltage vs. output voltage

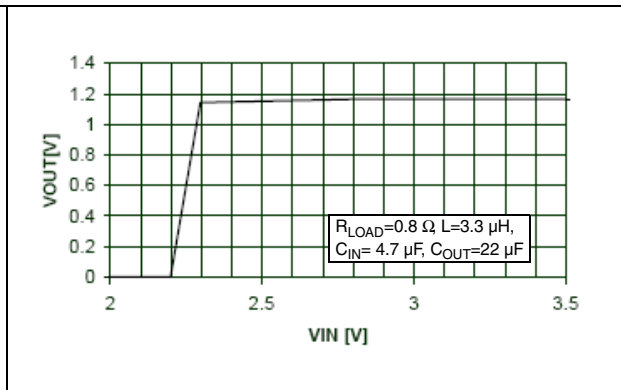

Figure 8. Efficiency vs. output current

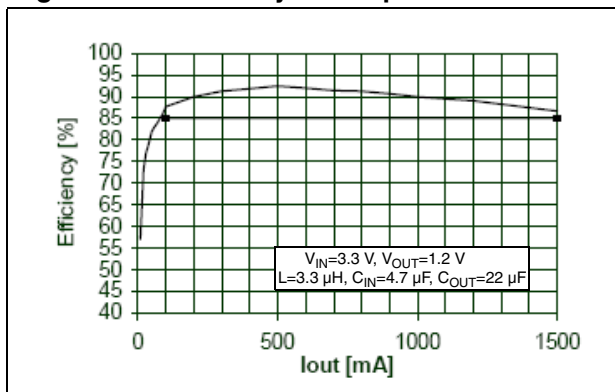

Figure 9. Feedback voltage vs. temperature

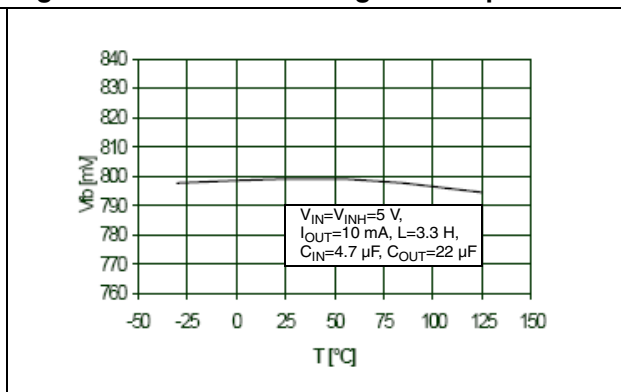

Figure 10. Inhibit voltage vs. input voltage

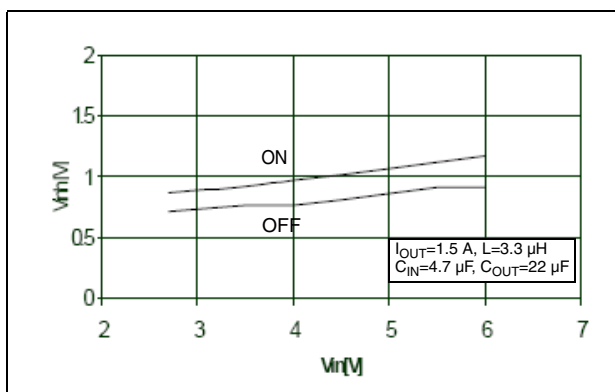
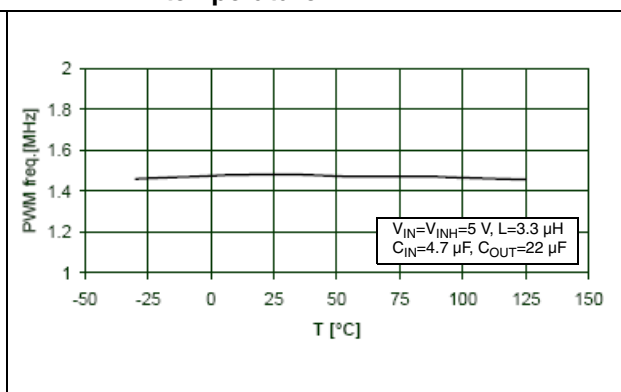

Figure 11. Switching frequency vs. temperature



5 Bill of materials

Table 1. BOM with most often used components

Name	Value	Material	Brand	P/N
C1	4.7 μ F	Ceramic	TDK	C3216X7R1C475K
		Ceramic	Murata	GRM21BR71A255KA12L
C2	22 μ F	Ceramic	TDK	C3225X7R1C226M
		Ceramic	Murata	GRM32ER61C226KE20L
C3				Not mounted
L	3.3 μ H		TDK	RLF7030T-3R3M4R1
	4.7 μ H		TDK	RLF7030T-4R7M3R4
			Coiltronix	DR73-4R7

6 Revision history

Table 2. Document revision history

Date	Revision	Changes
19-Jun-2006	1	Initial release.
20-Mar-2008	2	<ul style="list-style-type: none"> – Modified: Equation 12, 13, 15 – Modified: Figure 6, 7, 8, 9, 10, 11 – Modified: Table 1

Please Read Carefully:

Information in this document is provided solely in connection with ST products. STMicroelectronics NV and its subsidiaries ("ST") reserve the right to make changes, corrections, modifications or improvements, to this document, and the products and services described herein at any time, without notice.

All ST products are sold pursuant to ST's terms and conditions of sale.

Purchasers are solely responsible for the choice, selection and use of the ST products and services described herein, and ST assumes no liability whatsoever relating to the choice, selection or use of the ST products and services described herein.

No license, express or implied, by estoppel or otherwise, to any intellectual property rights is granted under this document. If any part of this document refers to any third party products or services it shall not be deemed a license grant by ST for the use of such third party products or services, or any intellectual property contained therein or considered as a warranty covering the use in any manner whatsoever of such third party products or services or any intellectual property contained therein.

UNLESS OTHERWISE SET FORTH IN ST'S TERMS AND CONDITIONS OF SALE ST DISCLAIMS ANY EXPRESS OR IMPLIED WARRANTY WITH RESPECT TO THE USE AND/OR SALE OF ST PRODUCTS INCLUDING WITHOUT LIMITATION IMPLIED WARRANTIES OF MERCHANTABILITY, FITNESS FOR A PARTICULAR PURPOSE (AND THEIR EQUIVALENTS UNDER THE LAWS OF ANY JURISDICTION), OR INFRINGEMENT OF ANY PATENT, COPYRIGHT OR OTHER INTELLECTUAL PROPERTY RIGHT.

UNLESS EXPRESSLY APPROVED IN WRITING BY AN AUTHORIZED REPRESENTATIVE OF ST, ST PRODUCTS ARE NOT DESIGNED, AUTHORIZED OR WARRANTED FOR USE IN MILITARY, AIR CRAFT, SPACE, LIFE SAVING, OR LIFE SUSTAINING APPLICATIONS, NOR IN PRODUCTS OR SYSTEMS, WHERE FAILURE OR MALFUNCTION MAY RESULT IN PERSONAL INJURY, DEATH, OR SEVERE PROPERTY OR ENVIRONMENTAL DAMAGE.

Resale of ST products with provisions different from the statements and/or technical features set forth in this document shall immediately void any warranty granted by ST for the ST product or service described herein and shall not create or extend in any manner whatsoever, any liability of ST.

ST and the ST logo are trademarks or registered trademarks of ST in various countries.

Information in this document supersedes and replaces all information previously supplied.

The ST logo is a registered trademark of STMicroelectronics. All other names are the property of their respective owners.

© 2008 STMicroelectronics - All rights reserved

STMicroelectronics group of companies

Australia - Belgium - Brazil - Canada - China - Czech Republic - Finland - France - Germany - Hong Kong - India - Israel - Italy - Japan - Malaysia - Malta - Morocco - Singapore - Spain - Sweden - Switzerland - United Kingdom - United States of America

www.st.com