



## AMIS-492x0 Fieldbus MAU Evaluation Board User's Manual

ON Semiconductor®

<http://onsemi.com>

### EVAL BOARD USER'S MANUAL

#### Introduction

ON Semiconductor offers the AMIS-492x0 Fieldbus Media Access Unit (MAU) as part of an overall industrial network communication solution. Please refer to the AMIS-492x0 data sheet for more information on this integrated circuit. The scope of this user's manual focuses on a reference design and board that ON Semiconductor also offers its customers, and which satisfies the Foundation Fieldbus H1 or Profibus PA physical layer network requirement.

This user's manual helps the user design in the AMIS-492x0 MAU, by referring to a usable board design

known to pass the Foundation Fieldbus Physical Layer Conformance (Specification FF830, Rev 1.5).

The reference design discussed in this document also includes additional flexible sub-circuits not discussed in the AMIS-492x0 data sheet, that help the user optimally fit the AMIS-492x0 to their application.

#### Fieldbus Node Description

Figure 1 shows a typical, complete node using the AMIS-492x0.

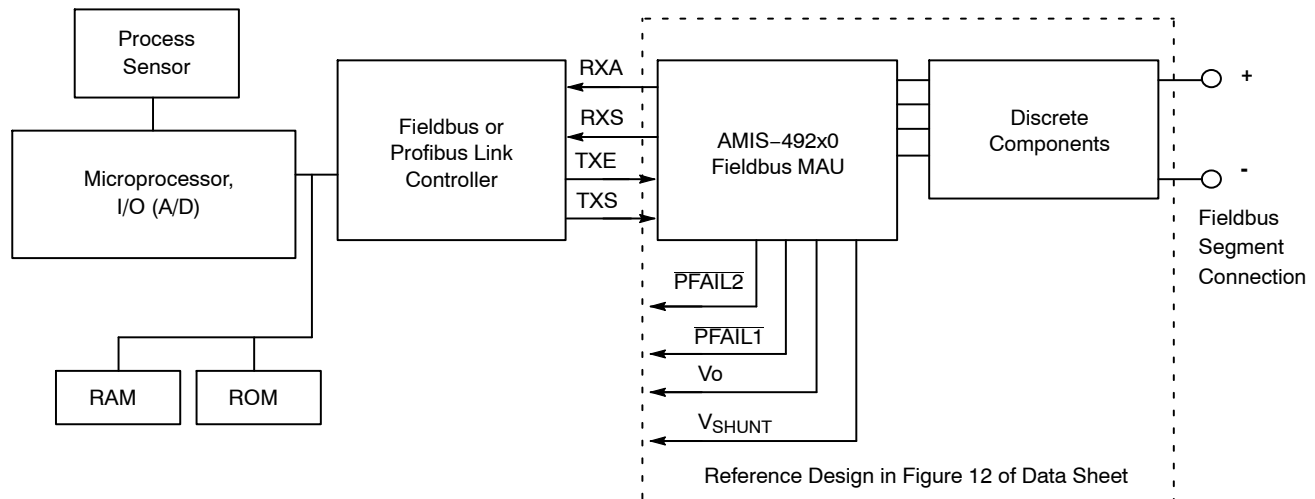

Figure 1. Complete Fieldbus Device using AMIS-492x0

A link controller is placed between a typical microprocessor and the AMIS-492x0 MAU to provide Manchester encoding and decoding of the data to be transmitted or received, respectively. It may be possible to program a high-end microprocessor to handle the Manchester style data stream, but the effort to do so is likely cost prohibitive.

One example of a suitable link controller is the UFC100-F1 by Softing/Aniotek, Inc.

<http://www.softing.com/home/en/industrial-automation/products/foundation-fieldbus/device-integration/universal-field-controller.php?navanchor=3010446>

#### AMIS-492x0 Fieldbus MAU Reference Design

ON Semiconductor has developed a reference design for commercial use in a Foundation Fieldbus H1 or Profibus PA application.

Figure 12 in the AMIS-492x0 data sheet shows an example of external circuitry required to connect the AMIS-492x0 to an IEC 61158-2 conformant network. That schematic is of a circuit that passed the Foundation Fieldbus Physical Layer Conformance test as specified in Foundation Fieldbus Specification FF830, Rev 1.5.

There are many alternative designs and it is beyond the scope of this document to identify all possible

# AMIS-49200EVB

configurations. We strongly encourage customers to use the ON Semiconductor reference design to provide the most effective application support.

Whether or not the ON Semiconductor reference design is used, we recommend that the customer perform their own physical layer board test to ensure conformance. In addition, board layout can alter the behavior of all circuit implementations, even designs that follow the recommended implementation. Fieldbus Foundation ([www.fieldbus.org](http://www.fieldbus.org)) provides the required test specifications to their membership only. ON Semiconductor cannot provide these specifications to customers.

Although the ON Semiconductor reference design in the AMIS-492x0 data sheet passed physical layer conformance

as is, often this design can be slightly modified given unique application-related traits. Figure 12 in the AMIS-492x0 data sheet shows a general schematic independent of board layout. Figure 2 shows the AMIS-492x0 reference design that includes extra components to accommodate such application flexibility. This schematic together with PCB build files and a bill of material (BOM) constitute the AMIS-492x0 reference design package which can be found at the link listed in this document's reference section. The design in Figure 2 also passes the Foundation Fieldbus test (FF830, Rev. 1.5).

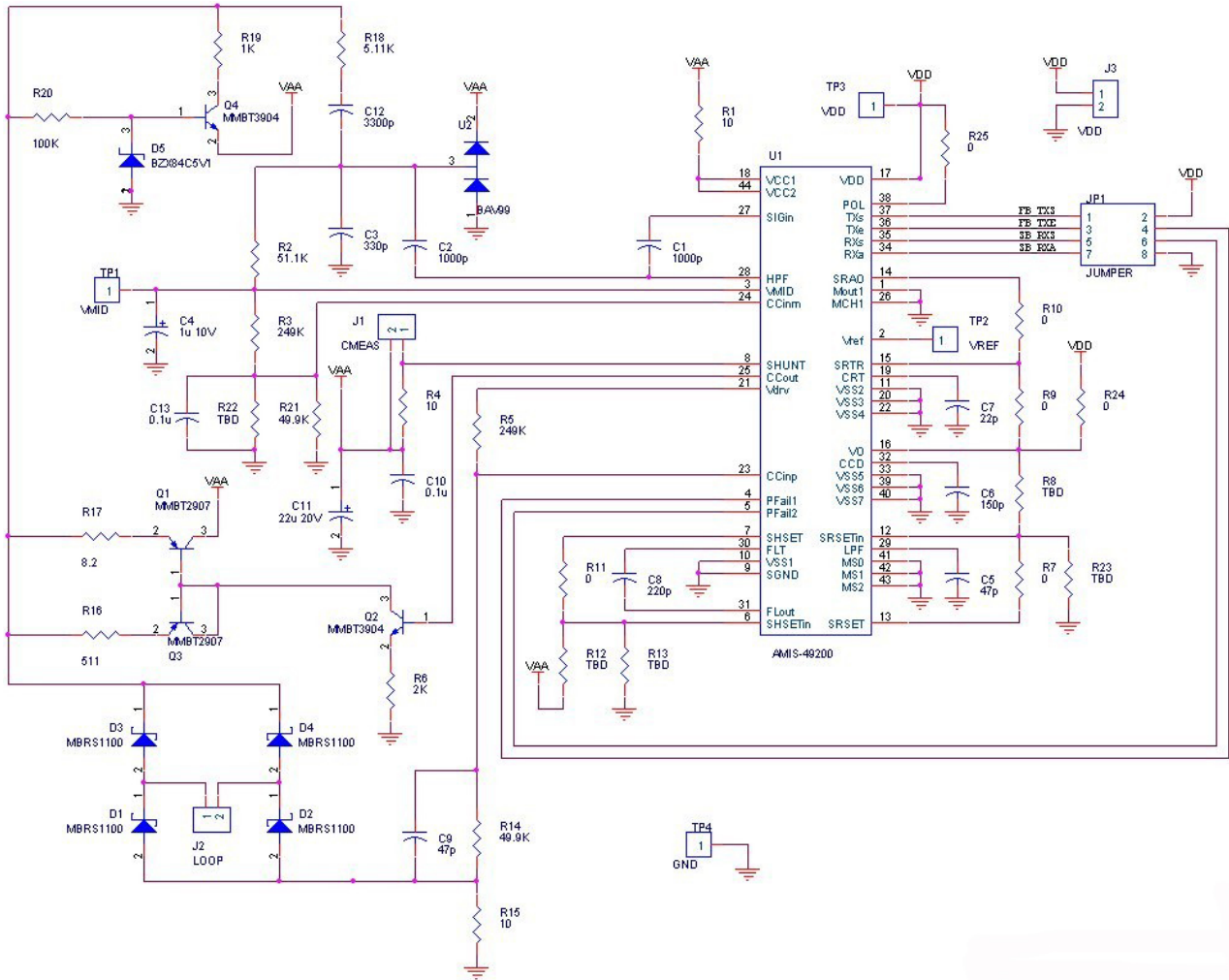

**Figure 2. AMIS-492x0 Reference Design Schematic**

Please note the following:

- A bridge rectifier was added to interface with the medium. This allows proper, correct operation regardless of polarity hook-up.
- Test points are included to provide convenient access to the circuit for development purposes.

- Certain sub-circuits (e.g. voltage dividers) have been added to adjust analog (shunt regulator) supply voltage, digital (series regulator) supply voltage, and loop current settings (loop current regulator). Figure 2 shows these components as “TBD” to be adjusted by the customer as needed to modify the design to their application requirements. The “TBD” resistors not installed by default on the reference board are listed in Table 1.

**Table 1. Components That May Be Modified on the Reference Board**

Resistor	Used to Adjust
R12	Shunt regulator voltage
R13	Shunt regulator voltage
R8	Series regulator voltage
R23	Series regulator voltage
R22	Loop current

### Shunt Regulator

See Section 4.2.1 and Figure 4 in the AMIS-492x0 data sheet.

As assembled the shunt regulator output will be 5.02 V at Pin 8 (SHUNT). This voltage is set by connecting Pin 7 (SHSET) to Pin 6 (SHSETin) via R11 (zero Ω). This connection connects the internal voltage divider to the shunt regulator amplifier non-inverting input.

To set the shunt regulator output to another voltage, remove R11 and install R12 and R13. The shunt regulator voltage can be set in the range of 4.75 V to 6.2 V. The formula for this is:

$$V_{SHUNT} = V_{ref} \cdot \left( 1 + \frac{R_{12}}{R_{13}} \right) \text{ where } V_{ref} = 1.18 \text{ V (eq. 1)}$$

### Series Regulator

See Section 4.2.2 and Figure 5 in the AMIS-492x0 data sheet.

As assembled the series regulator output will be 3.04 V at Pin 16 (VO). This voltage is set by connecting Pin 13 (SRSET) to Pin 12 (SRSETin) via R7 (zero Ω). This connection connects the internal voltage divider to the shunt regulator amplifier non-inverting input. Also Pin 14 (SRAO) is connected to Pin 15 (SRTR) via R10 (zero Ω). This connects the output of the series regulator amplifier to the pass transistor.

To set the series regulator output to another voltage, remove R7 and install R8 and R23. The series regulator voltage can be set in the range of 2.85V to 3.5V. The formula for this is:

$$V_O = V_{ref} \cdot \left( 1 + \frac{R_8}{R_{23}} \right) \text{ where } V_{ref} = 1.18 \text{ V (eq. 2)}$$

The board as shipped will be configured to have the series regulator operating and set to 3 V using the internal voltage

divider. In this configuration R24, R10 and R7 are all installed with 0 ohm resistors. R9, R8 and R23 are not populated.

To disable the series regulator (e.g. to consume as little power as possible), remove R24, R10 and R7. Install 0 Ohm jumpers in R9 and R23, and leave R8 empty.

R9 shorts out the pass transistor so that it cannot turn on. R23 grounds the non-inverting input to the regulator amplifier and forces the output to saturate so that it cannot oscillate. Removing R10 relieves the regulator amplifier output of any possible load. Removing R7 isolates the internal divider. Removing R24 disconnects the series regulator output from the external (digital) rail.

### Loop Current Regulator

The value of the loop current is set by the parallel combination of R21 and R22. As shipped, R22 is not installed and R21 = 49.9 kΩ. This sets the loop current to 10 mA. Decreasing the value of the parallel combination of R21 and R22 increases the loop current. The formula to calculate the value of the loop current is in Equation 3.

### Customer Board Tips and Suggestions for Production

The customer might find the following suggestions helpful in planning for production and/or development:

- Use full embedded power and ground planes in a four-layer PCB configuration to reduce the likelihood of noise. The AMIS-492x0 reference board is a two-layer board to ease evaluation and development.
- To accommodate board space constraints, you might want to use surface-mount components. The AMIS-492x0 reference board uses a few thru-hole components.
- Pin 36 (TXE) and Pin 37 (TXS) are CMOS digital inputs and cannot float. If the board is not connected to a link controller or other circuitry at JP1, TXS (FB\_TXS on JP1) must be pulled to VDD, and TXE (FB\_TXE on JP1) must be pulled to ground.

### AMIS-492x0 Evaluation Kit (AMIS-49200EVB)

ON Semiconductor provides an evaluation kit that showcases the AMIS-492x0 Fieldbus MAU on-board for real-time demonstration and evaluation. The AMIS-49200EVB kit includes:

- Reference board following the schematic in Figure 2, including the AMIS-49200 device.
- Connector to aid evaluation of MAU and link controller interface.

Please contact your local ON Semiconductor sales representative for AMIS-49200EVB price and availability.

$$I_{loop} = \frac{\left\{ \left[ \left( \frac{V_{drv}}{R_5} \right) - V_{mid} \cdot \left( \frac{R_{21||22}}{R_5 \cdot (R_3 + R_{21||22})} \right) \right] \cdot R_{14} \right\} - \left\{ V_{mid} \cdot \left( \frac{R_{21||22}}{R_3 + R_{21||22}} \right) \right\}}{R_{15}} \quad \text{(eq. 3)}$$

where:  $V_{drv} = 2.5 \text{ V}$ ,  $V_{mid} = 2.0 \text{ V}$ ,  $R_5 = R_3 = 249 \text{ k}\Omega$ ,  $R_{15} = 10 \text{ }\Omega$ ,  $R_{21||22} \leq 49.9 \text{ k}\Omega$

# AMIS-49200EVB

## Appendix (A) Component Label Cross Reference

The component values in Figure 2 in this document and Figure 12 in the AMIS-492x0 data sheet are differently labeled. For convenience, a cross-reference list is found in Table 2.

**Table 2. Component Cross-Reference List between Reference Design and Data Sheet**

Reference Board	Data Sheet	Reference Board	Data Sheet	Reference Board	Data Sheet
C1	C5	D5	D3	R13	N/A
C2	C6	Q1	Q2	R14	R11
C3	C9	Q2	Q4	R15	R10
C4	C8	Q3	Q3	R16	R8
C5	C3	Q4	Q1	R17	R7
C6	C1	R1	N/A	R18	R4
C7	C2	R2	R1	R19	R6
C8	C4	R3	R2	R20	R5
C9	C11	R4	n/a	R21	R3
C10	N/A	R5	R12	R22	N/A
C11	C10	R6	R9	R23	N/A
C12	C7	R7	N/A	R24	N/A
C13	N/A	R8	N/A	R25	N/A
D1	N/A	R9	N/A	U2	D1
D2	N/A	R10	N/A	U2	D2
D3	N/A	R11	N/A	VAA	Vshunt
D4	N/A	R12	N/A		

### References

- AMIS-492x0 Fieldbus MAU Data Sheet; [http://www.onsemi.com/pub\\_link/Collateral/49200-D.PDF](http://www.onsemi.com/pub_link/Collateral/49200-D.PDF)
- AMIS-492x0 Reference Design Package including schematic, BOM and PCB layout files; <http://onsemi.com/PowerSolutions/product.do?id=AMIS-49200-XTD>

### Company or Products Inquiry

For more information about ON Semiconductor's products or services visit our Web site at <http://onsemi.com>.

ON Semiconductor and the ON Semiconductor logo are trademarks of Semiconductor Components Industries, LLC dba ON Semiconductor or its subsidiaries in the United States and/or other countries. ON Semiconductor owns the rights to a number of patents, trademarks, copyrights, trade secrets, and other intellectual property. A listing of ON Semiconductor's product/patent coverage may be accessed at [www.onsemi.com/site/pdf/Patent-Marking.pdf](http://www.onsemi.com/site/pdf/Patent-Marking.pdf). ON Semiconductor is an Equal Opportunity/Affirmative Action Employer. This literature is subject to all applicable copyright laws and is not for resale in any manner.

The evaluation board/kit (research and development board/kit) (hereinafter the "board") is not a finished product and is as such not available for sale to consumers. The board is only intended for research, development, demonstration and evaluation purposes and should as such only be used in laboratory/development areas by persons with an engineering/technical training and familiar with the risks associated with handling electrical/mechanical components, systems and subsystems. This person assumes full responsibility/liability for proper and safe handling. Any other use, resale or redistribution for any other purpose is strictly prohibited.

The board is delivered "AS IS" and without warranty of any kind including, but not limited to, that the board is production-worthy, that the functions contained in the board will meet your requirements, or that the operation of the board will be uninterrupted or error free. ON Semiconductor expressly disclaims all warranties, express, implied or otherwise, including without limitation, warranties of fitness for a particular purpose and non-infringement of intellectual property rights.

ON Semiconductor reserves the right to make changes without further notice to any board.

You are responsible for determining whether the board will be suitable for your intended use or application or will achieve your intended results. Prior to using or distributing any systems that have been evaluated, designed or tested using the board, you agree to test and validate your design to confirm the functionality for your application. Any technical, applications or design information or advice, quality characterization, reliability data or other services provided by ON Semiconductor shall not constitute any representation or warranty by ON Semiconductor, and no additional obligations or liabilities shall arise from ON Semiconductor having provided such information or services.

The boards are not designed, intended, or authorized for use in life support systems, or any FDA Class 3 medical devices or medical devices with a similar or equivalent classification in a foreign jurisdiction, or any devices intended for implantation in the human body. Should you purchase or use the board for any such unintended or unauthorized application, you shall indemnify and hold ON Semiconductor and its officers, employees, subsidiaries, affiliates, and distributors harmless against all claims, costs, damages, and expenses, and reasonable attorney fees arising out of, directly or indirectly, any claim of personal injury or death associated with such unintended or unauthorized use, even if such claim alleges that ON Semiconductor was negligent regarding the design or manufacture of the board.

This evaluation board/kit does not fall within the scope of the European Union directives regarding electromagnetic compatibility, restricted substances (RoHS), recycling (WEEE), FCC, CE or UL, and may not meet the technical requirements of these or other related directives.

**FCC WARNING** – This evaluation board/kit is intended for use for engineering development, demonstration, or evaluation purposes only and is not considered by ON Semiconductor to be a finished end product fit for general consumer use. It may generate, use, or radiate radio frequency energy and has not been tested for compliance with the limits of computing devices pursuant to part 15 of FCC rules, which are designed to provide reasonable protection against radio frequency interference. Operation of this equipment may cause interference with radio communications, in which case the user shall be responsible, at its expense, to take whatever measures may be required to correct this interference.

ON Semiconductor does not convey any license under its patent rights nor the rights of others.

**LIMITATIONS OF LIABILITY:** ON Semiconductor shall not be liable for any special, consequential, incidental, indirect or punitive damages, including, but not limited to the costs of requalification, delay, loss of profits or goodwill, arising out of or in connection with the board, even if ON Semiconductor is advised of the possibility of such damages. In no event shall ON Semiconductor's aggregate liability from any obligation arising out of or in connection with the board, under any theory of liability, exceed the purchase price paid for the board, if any.

For more information and documentation, please visit [www.onsemi.com](http://www.onsemi.com).

---

## PUBLICATION ORDERING INFORMATION

### LITERATURE FULFILLMENT:

Email Requests to: [orderlit@onsemi.com](mailto:orderlit@onsemi.com)

ON Semiconductor Website: [www.onsemi.com](http://www.onsemi.com)

### TECHNICAL SUPPORT

North American Technical Support:

Voice Mail: 1 800-282-9855 Toll Free USA/Canada

Phone: 011 421 33 790 2910

Europe, Middle East and Africa Technical Support:

Phone: 00421 33 790 2910

For additional information, please contact your local Sales Representative