

REV	CHANGE	DATE	DRN	CHK
	Drawn	12/20/16	SJ	T

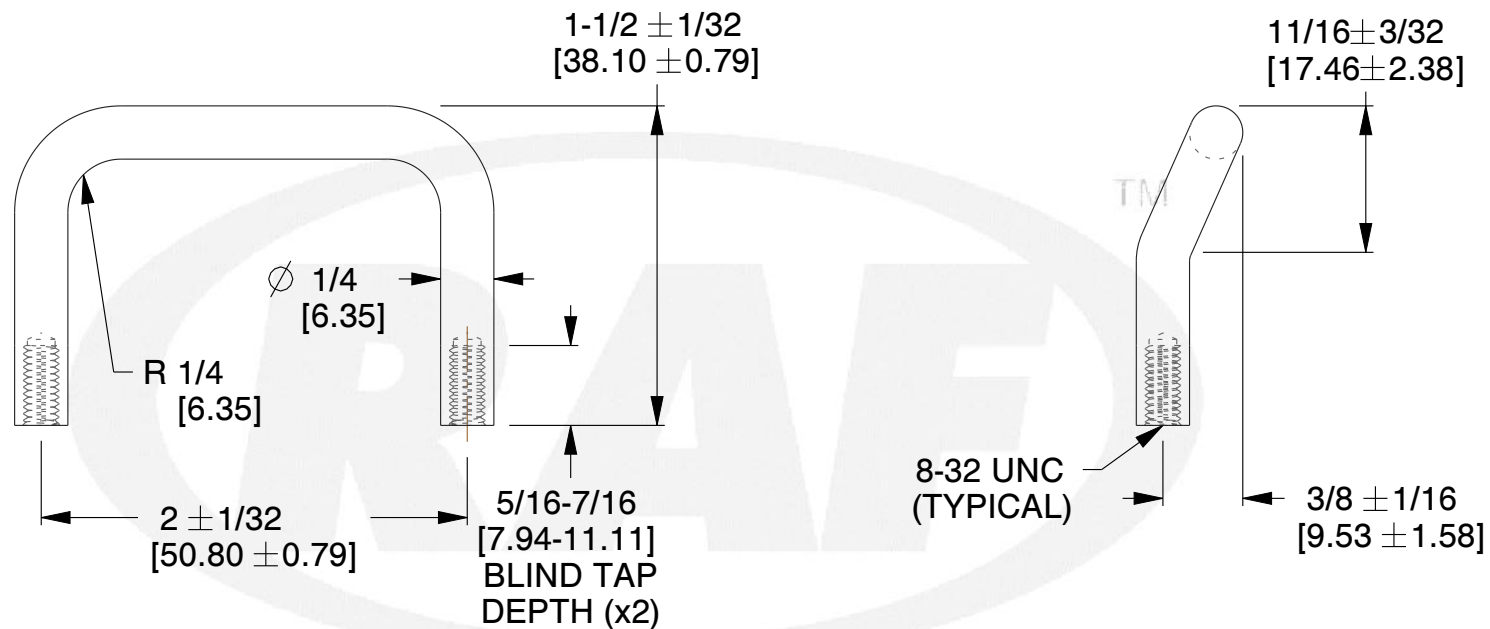

NOTES:

1. Material : Stainless Steel (ASTM-A-581, A-582) (RoHS Comp.)
2. Finish : Nickel QQ-N-290 Class 1 Grade G
3. % of Thread for Tapped Holes : Form Tap - 55 | Cut Tap - 65
- 4: Threads are Supplied Cut or Rolled at RAF's Option Unless Noted on Order.
5. Threads are to Commercial 2A and 2B Standards per Handbook H-28 (Part 1)
6. All Drawing Dimensions are in Inches Unless Noted Otherwise
7. ASME Y14.5M - 2009
8. Unless otherwise specified; Edge Breaks, Radii or Countersinks 0.005-0.015

COMPONENT	HANDLES
8266-832-SS	SCALE
	1.11
	SHEET
INTERNAL THREAD HANDLE	1 of 1



95 Silvermine Rd., Seymour CT 06483
Tel: 203-888-2133, Fax: 203-888-9860

This Drawing is the Property of RAF. It contains confidential, proprietary information that is RAF property. Do not disclose to or duplicate for others except as authorized by RAF.

TOLERANCES
ALL DIMENSIONS ARE INCHES (UNLESS OTHERWISE SPECIFIED)
METALLIC
LENGTHS < 6 INCHES ± 0.005
LENGTH > 6 INCHES ± 0.010
DIAMETERS: ± 0.005
NON-METALLIC
LENGTH: ± 0.010 DIAMETERS: ± 0.010
INTERNAL THREADS:
MINIMUM THREAD DEPTH