

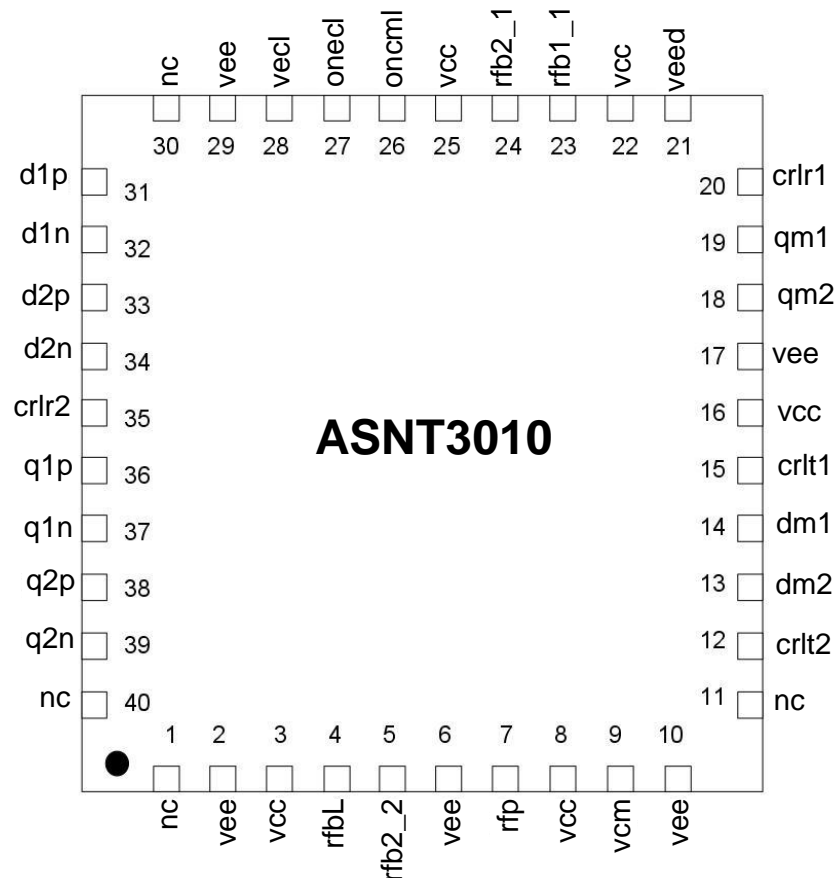

## ASNT3010-PQB DC-2Gbps LVDS/CMOS/LVDS Converter and Signal Splitter

- 2-channel LVDS-to-CMOS converter (Receiver) and 2-channel CMOS-to-LVDS converter (Transmitter)
- Optional signal splitter function with selectable inversion
- Optional DS (Data/Strobe) encoding/decoding for compatibility with Space Wire Standard
- Programmable LVDS/CML/ECL Receiver input interface
- True LVDS Transmitter output interface
- Flexible selection of enabling and operational modes of the channels
- High-impedance states of disabled CMOS outputs
- Single +3.3V power supply
- Industrial temperature range
- Power consumption: 115mW with all 4 channels enabled
- Standard MLF/QFN 40-pin package



## DESCRIPTION

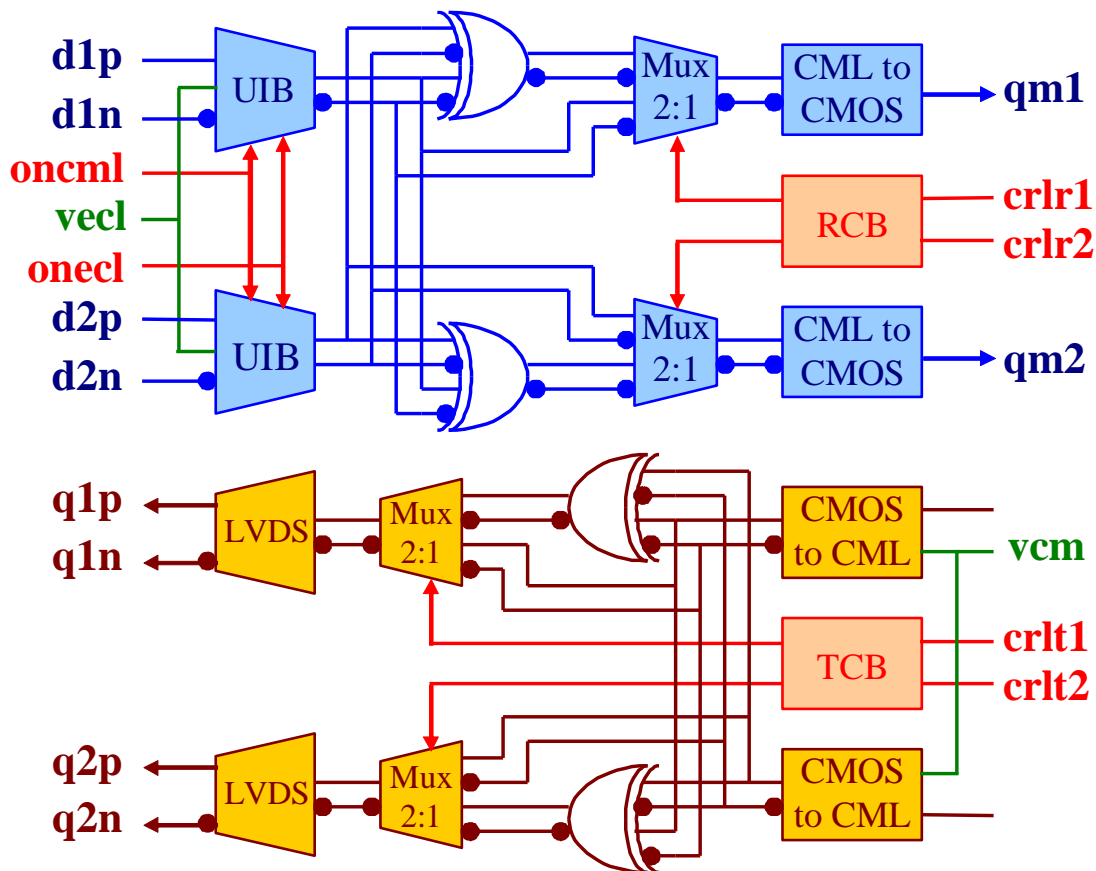

Fig. 1. Functional Block Diagram

ASNT3010-PQB is a bi-directional 4-channel digital interface converter. The part shown in Fig. 1 includes two individual receiver channels with programmable LVDS/CML/ECL differential inputs **d1p/d1n**, **d2p/d2n**, and CMOS outputs **qm1**, **qm2**; as well as two individual transmitter channels with CMOS inputs **dm1**, **dm2** and LVDS differential outputs **q1p/q1n**, **q2p/q2n**.

All channels can be independently enabled or disabled by control signals **crtr1**, **crtr2**, **crtl1**, **crtl2**. When a receiver channel is disabled, the corresponding CMOS output drivers are set to a high impedance (high-Z) state. The individual receiver or transmitter channels can be combined into a corresponding Space Wire receiver or transmitter with an optional data/strobe (DS) encoding or decoding respectively. The assignment of the data and strobe, or data and clock signals to the individual channels is user-selectable.

Dual transmitter and/or receiver channels can be used for splitting one of the input signals into two exact copies at the two corresponding outputs. The signal at the second output can be inverted using the second input as a selector (a differential DC signal must be applied to the LVDS input). Detailed instructions for using this operational mode are available on request.

The converter operates from a single +3.3V power supply. The device is characterized for operation from -25°C to 125°C of junction temperature.



## Universal IB

The proprietary Universal Input Buffer (UIB) is designed to support one of three interfaces: LVDS, CML, or ECL. The type of interface is defined by two CMOS control signals **oncm1** and **onecl** as shown in Table 1. In the ECL mode, it is required that the pin **vecl** is terminated to the specified voltage.

Table 1. LS Input Interface Selection

| <b>oncm1</b>         | <b>onecl</b>         | <b>Interface type</b> | <b>Internal termination</b> | <b>vecl, V</b> |
|----------------------|----------------------|-----------------------|-----------------------------|----------------|
| <b>vee</b> (default) | <b>vee</b> (default) | LVDS                  | 100Ohm differential         | not used       |
| <b>vee</b>           | <b>vcc</b>           | ECL                   | 50Ohm SE to <b>vecl</b>     | <b>vcc-2.0</b> |
| <b>vcc</b>           | <b>vee</b>           | CML                   | 50Ohm SE to <b>vcc</b>      | not used       |
| <b>vcc</b>           | <b>vcc</b>           | Not allowed           |                             |                |

In the LVDS mode, the buffer exceeds the requirements of standards IEEE Std. 1596.3-1996 and ANSI/TIA/EIA-644-1995. UIB is designed to accept differential signals with amplitudes above 60mV peak-to-peak, DC common mode voltage variation between the negative (**vee**) and positive (**vcc**) supply rails, and AC common mode noise with a frequency up to 5MHz and voltage levels ranging from 0 to 2.4V. It can also receive single-ended signals with swings above 60mVp-p and threshold voltages between **vee** and **vcc**.

## CML-to-CMOS Converter

The CML-to-CMOS converter represents the output buffer of the receiver. It includes a signal converter based on a current mirror architecture and an output CMOS driver. The block operates at a data rate up to 2Gbps.

## CMOS-to-CML Converter

The input CMOS-to-CML converter represents the input buffer of the transmitter. It is designed as a standard CML buffer with additional resistive dividers required for handling rail-to-rail CMOS signals.

## LVDS Output Buffer

The proprietary LVDS output buffer utilizes NPN HBTs that are available in standard BiCMOS technologies. It accepts internal CML signals and converts them into output LVDS signals. The buffer utilizes a special architecture that ensures operation at data rates up to 2Gbps with a low power consumption level of 19mW. The buffer satisfies all the requirements of the IEEE Std. 1596.3-1996 and ANSI/TIA/EIA-644-1995.

## Internal Data Processing Circuitry

The internal parts of all 4 channels include an XOR and multiplexer 2:1 CML cells. When activated, the XOR performs the DS encoding or decoding required by the Space Wire protocol, while the multiplexer operates as a selector of either the channel's input signal or the XOR-processed signals. The corresponding control signals are generated by the receiver or transmitter control blocks (RCB or TCB) from the 3-state external control signals.

Each channel can function as an independent converter, as well as a data/strobe or clock/strobe Space Wire encoder/decoder in accordance with Table 2 or Table 3. In the second mode, the device can also



perform the 1-to-2 data splitting operation. The notations Out1, Out2, In1, and In2 in the tables represent the logic states of the corresponding outputs and inputs, either differential or single-ended.

Table 2. Receiver Operational Modes

| Mode           | crlr1         | crlr2         | Channel 1 out (qm1)                                    | Channel 2 out (qm2)                                    |
|----------------|---------------|---------------|--|--|
| 2 channels     | vee           | vee           | High-Z   | High-Z   |
| 2 channels     | vee           | N/C (Default) | High-Z   | Out2=In2   |
| 2 channels     | vee           | vcc           | High-Z   | Out2=In2   |
| 2 channels     | N/C (Default) | vee           | Out1=In1   | High-Z   |
| 2 channels     | N/C (Default) | N/C (Default) | Out1=In1   | Out2=In2   |
| SW or splitter | N/C (Default) | vcc           | Out1=In1   | Out2=XOR(In1, In2), or<br>Out2=(+/-)In1 if In2="0"/"1" |
| 2 channels     | vcc           | vee           | Out1=In1   | High-Z   |
| SW or splitter | vcc           | N/C (Default) | Out1=XOR(In1, In2), or<br>Out1=(+/-)In2 if In1="0"/"1" | Out2=In2   |
| 2 channels     | vcc           | vcc           | Out1=In1   | Out2=In2   |

Table 3. Transmitter Operational Modes

| Mode           | crlt1         | crlt2         | Channel 1 outs (q1p/q1n)                               | Channel 2 outs (q2p/q2n)                               |
|----------------|---------------|---------------|--|--|
| 2 channels     | vee           | vee           | Equal undefined levels                                 | Equal undefined levels                                 |
| 2 channels     | vee           | N/C (Default) | Equal undefined levels                                 | Out2=In2   |
| 2 channels     | vee           | vcc           | Equal undefined levels                                 | Out2=In2   |
| 2 channels     | N/C (Default) | vee           | Out1=In1   | Equal undefined levels                                 |
| 2 channels     | N/C (Default) | N/C (Default) | Out1=In1   | Out2=In2   |
| SW or splitter | N/C (Default) | vcc           | Out1=In1   | Out2=XOR(In1, In2), or<br>Out2=(+/-)In1 if In2="0"/"1" |
| 2 channels     | vcc           | vee           | Out1=In1   | Equal undefined levels                                 |
| SW or splitter | vcc           | N/C (Default) | Out1=XOR(In1, In2), or<br>Out1=(+/-)In2 if In1="0"/"1" | Out2=In2   |
| 2 channels     | vcc           | vcc           | Out1=In1   | Out2=In2   |

## ABSOLUTE MAXIMUM RATINGS

Caution: Exceeding the absolute maximum ratings shown in Table 4 may cause damage to this product and/or lead to reduced reliability. Functional performance is specified over the recommended operating conditions for power supply and temperature only. AC and DC device characteristics at or beyond the absolute maximum ratings are not assumed or implied. All min and max voltage limits are referenced to ground (assumed vee).



Table 4. Absolute Maximum Ratings

| Parameter                        | Min | Max     | Units |
|----------------------------------|-----|---------|-------|
| Supply Voltage (VCC)             |     | 3.6     | V     |
| Power Consumption                |     | 130     | mW    |
| CMOS Input Voltage Swing         |     | VCC-VEE | V     |
| LVDS Input Voltage Swing (Diff.) |     | 1.0     | V     |
| Case Temperature                 |     | +90     | °C    |
| Storage Temperature              | -40 | +100    | °C    |
| Operational Humidity             | 10  | 98      | %     |
| Storage Humidity                 | 10  | 98      | %     |

## TERMINAL FUNCTIONS

| Name   | Number       | Type       | DESCRIPTION   |
|--------|--------------|------------|---|
| vcc    | 3,8,16,22,25 | PS         | Positive power supply   |
| vee    | 2,6,10,17,29 | PS         | Negative power supply (analog ground)   |
| veed   | 21           | PS         | Negative power supply (digital ground)  |
| vecl   | 28           | PS         | ECL input termination voltage   |
| nc     | 1,11,30,40   | -          | Floating package pins   |
| rfbL   | 4            | Control    | Internal reference voltages. Used only in test operational modes. <b>For normal operation must be left not connected.</b> |
| rfb2_2 | 5            | Control    |   |
| rfb2_1 | 24           | Control    |   |
| rfb1_1 | 23           | Control    |   |
| rfp    | 7            | Control    |   |
| crlt2  | 12           | Control    | Transmitter channel 2 activation control signal   |
| crlt1  | 15           | Control    | Transmitter channel 1 activation control signal   |
| crlr1  | 20           | Control    | Receiver channel 1 activation control signal  |
| oncm1  | 26           | Control    | Activation of the input CML termination mode  |
| onecl  | 27           | Control    | Activation of the input ECL termination mode  |
| crlr2  | 35           | Control    | Receiver channel 2 activation control signal  |
| vcm    | 9            | DC voltage | CMOS input threshold voltage, default=(VCC+VEE)/2   |
| dm2    | 13           | Input      | Transmitter channel 2 SE CMOS input   |
| dm1    | 14           | Input      | Transmitter channel 1 SE CMOS input   |
| qm2    | 18           | Output     | Receiver channel 2 SE CMOS output   |
| qm1    | 19           | Output     | Receiver channel 1 SE CMOS output   |
| d1p    | 31           | Input      | Receiver channel 1 LVDS direct input  |
| d1n    | 32           | Input      | Receiver channel 1 LVDS inverted input  |
| d2p    | 33           | Input      | Receiver channel 2 LVDS direct input  |
| d2n    | 34           | Input      | Receiver channel 2 LVDS inverted input  |
| q1p    | 36           | Output     | Transmitter channel 1 LVDS direct output  |
| q1n    | 37           | Output     | Transmitter channel 1 LVDS inverted output  |
| q2p    | 38           | Output     | Transmitter channel 2 LVDS direct output  |
| q2n    | 39           | Output     | Transmitter channel 2 LVDS inverted output  |



## ELECTRICAL CHARACTERISTICS

| PARAMETER   | MIN      | TYP     | MAX  | UNIT | COMMENTS               |
|---|----------|---------|------|------|------------------------|
| <b>General Parameters</b>                               |          |         |      |      |                        |
| vcc   | 3.14     | 3.3     | 3.47 | V    | ±5%                    |
| vee   |          | 0.0     |      | V    | LVDS ground            |
| veed  |          | 0.0     |      | V    | CMOS ground            |
| vecl  |          | vcc-2.0 |      | V    | ECL input termination  |
| Ivcc  |          | 35      |      | mA   | All channels enabled   |
| Power consumption                                       |          | 7.0     |      | mW   | 1 Receiver channel, DC |
|   |          | 20.0    |      | mW   | 1 Transmitter channel  |
|   |          | 115.0   |      | mW   | All channels enabled   |
| Junction temperature                                    | -25      | 50      | 125  | °C   |                        |
| <b>LVDS Inputs (d1p/d1n, d2p/d2n)</b>                   |          |         |      |      |                        |
| Data Rate   | 0.0      |         | 2.0  | Gbps |                        |
| DC common mode voltage                                  | vee      |         | vcc  | V    | DC voltage             |
| AC common mode voltage                                  | vee      |         | 2.4  | V    | AC signal <5MHz        |
| Sensitivity   |          | 60      |      | mV   |                        |
| <b>CMOS Inputs (dm1, dm2)</b>                           |          |         |      |      |                        |
| Data Rate   | 0.0      |         | 1.0  | Gbps |                        |
| Logic "1" level   | vcc -0.4 |         |      | V    |                        |
| Logic "0" level   |          |         | 0.4  | V    |                        |
| <b>LVDS Outputs (q1p/q1n, q2p/q2n)</b>                  |          |         |      |      |                        |
| Voltage Swing   |          | 320     |      | mV   | Each SE output         |
| CM voltage  | 1.2      |         | 1.25 | V    |                        |
| Impedance   |          | 77      | 122  | Ohm  | DC test                |
|   |          | 45      | 115  | Ohm  | AC test (0-2Gbps)      |
| Total current   | 5.2      |         | 5.7  | mA   | From vcc               |
| Output current  |          | 17      | 27   | mA   | Shorted to vee         |
|   |          | 4.5     | 7.0  | mA   | Shorted together       |
| Rise/Fall Times   |          | TBD     |      | pS   | 20%-80%                |
| <b>CMOS Outputs (qm1, qm2)</b>                          |          |         |      |      |                        |
| Logic "1" level   | vcc -0.2 |         |      | V    |                        |
| Logic "0" level   |          |         | 0.2  | V    |                        |
| Rise/Fall Times   |          | TBD     |      |      | 20%-to-80%             |
| Duty Cycle  | 45%      | 50%     | 55%  |      |                        |
| <b>CMOS Control Inputs (crlr1, crlr2, crlt1, crlt2)</b> |          |         |      |      |                        |
| Logic "1" level   | vcc -0.4 |         |      | V    |                        |
| Logic "0" level   |          |         | 0.4  | V    |                        |



## PACKAGE INFORMATION

The chip die is housed in a standard 40-pin QFN package shown in Fig. 2. It is recommended that the center heat slug located on the back side of the package is soldered to the **vee** plain that is ground for the positive supply.

The part's identification label is ASNT3010-PQB. The first 8 characters of the name before the dash identify the bare die including general circuit family, fabrication technology, specific circuit type, and part version while the 3 characters after the dash represent the package's manufacturer, type, and pin out count.

This device complies with the Restriction of Hazardous Substances (RoHS) per 2011/65/EU for all ten substances.

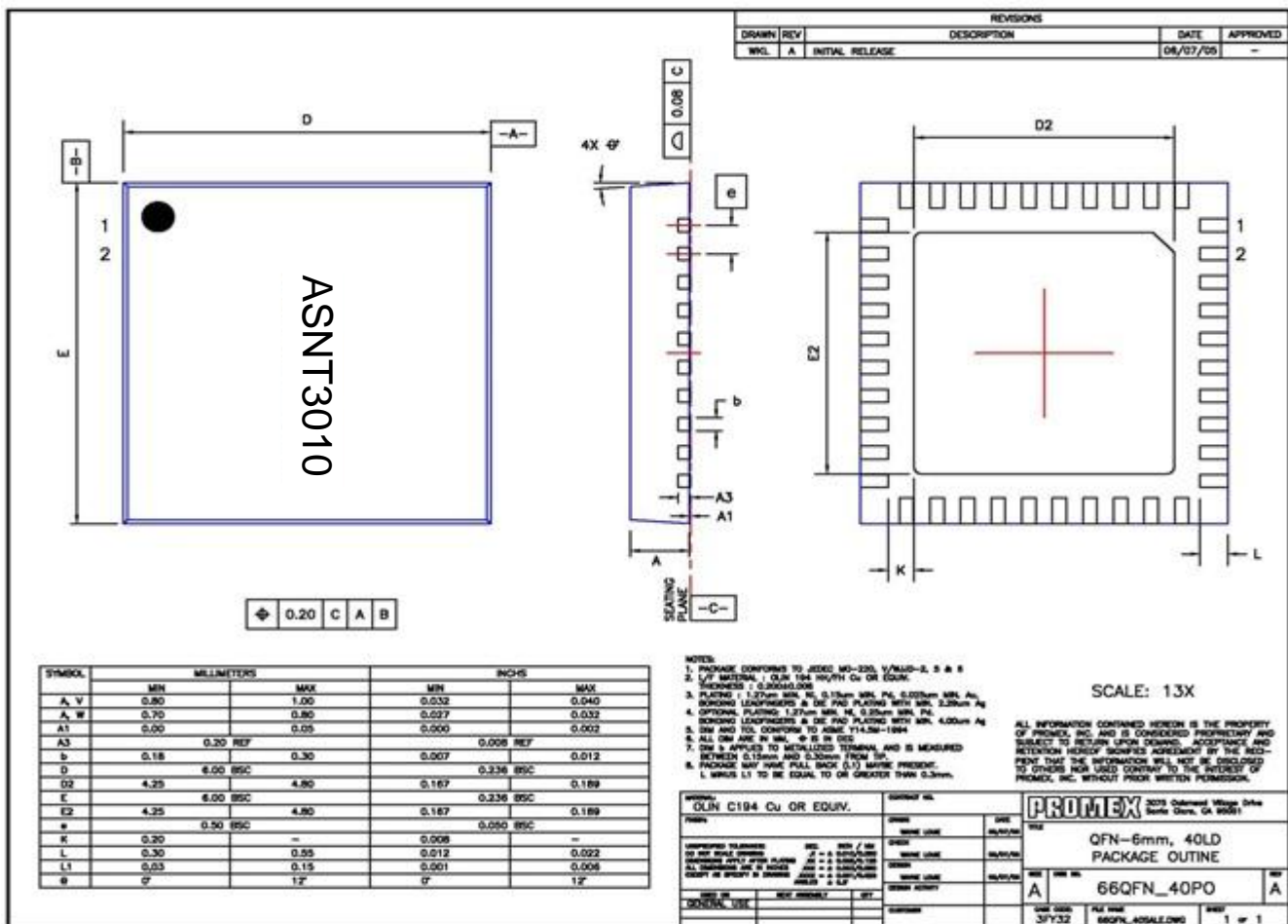

Fig. 2. QFN 40-Pin Package Drawing (All Dimensions in mm)



## REVISION HISTORY

| Revision | Date    | Changes   |
|----------|---------|---|
| 6.1.2    | 02-2020 | Updated Package Information   |
| 6.0.2    | 07-2019 | Updated Letterhead  |
| 6.0.1    | 03-2013 | Revised title<br>Revised description<br>Added pin out diagram<br>Corrected block diagram<br>Revised Operational Modes tables<br>Added absolute maximum ratings<br>Revised electrical characteristics<br>Revised package information<br>Added package mechanical drawing<br>Added revision history<br>Updated format |
| 5.0      | 09-2009 | Revised electrical characteristics  |
| 4.0      | 02-2008 | Revised electrical characteristics section<br>Revised packaging information section   |
| 3.0      | 06-2007 | Revised electrical characteristics section  |
| 2.0      | 04-2007 | Revised terminal functions section  |
| 1.0      | 01-2007 | First release   |