

		PANEL THICKNESS AND HARDWARE INSTALLATION															
		11W07 - LARGE SHOULDER NUT (K620)								11W11 - SMALL SHOULDER NUT (K619)							
PANEL THICKNESS		0.050	0.055	0.060	0.065	0.070	0.075	0.080	0.085	0.090	0.095	0.100	0.105	0.110	0.115	0.120	0.125
WASHER (K178)		YES	YES	YES	YES	YES	NO	NO	NO	NO	YES	YES	YES	YES	YES	NO	NO

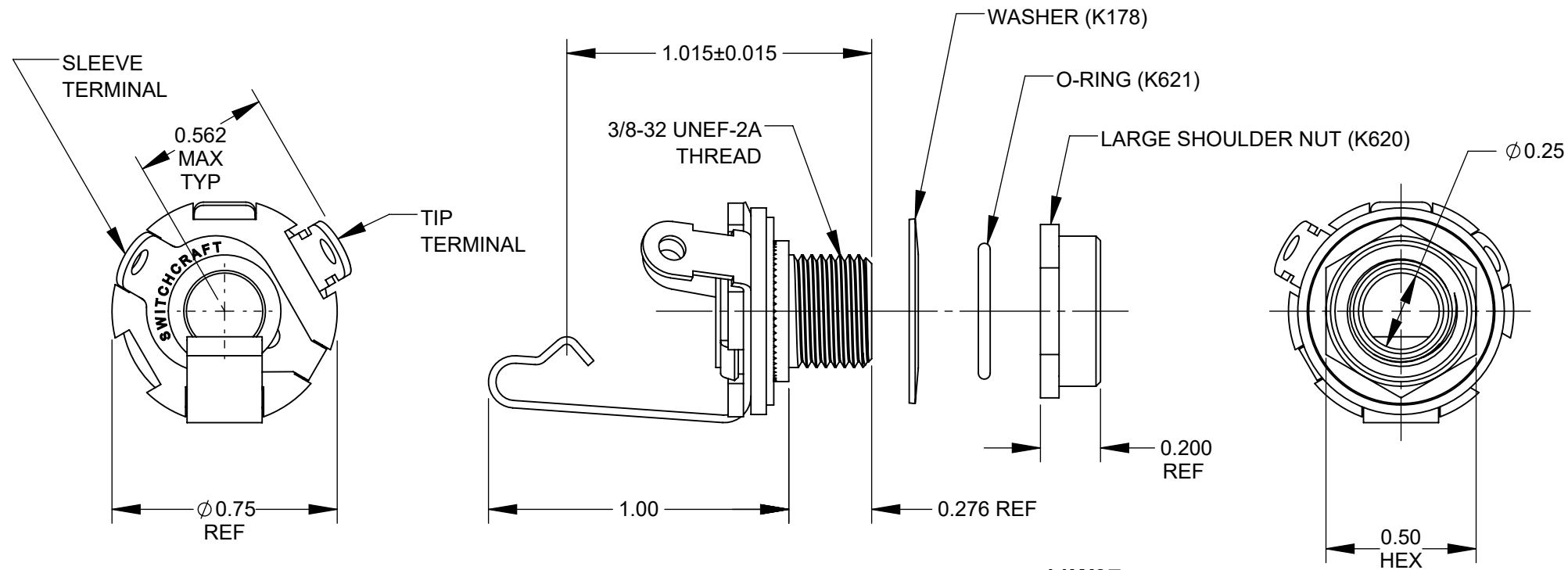

**11W07**  
SEALED JACK  
(WHEN MATED)

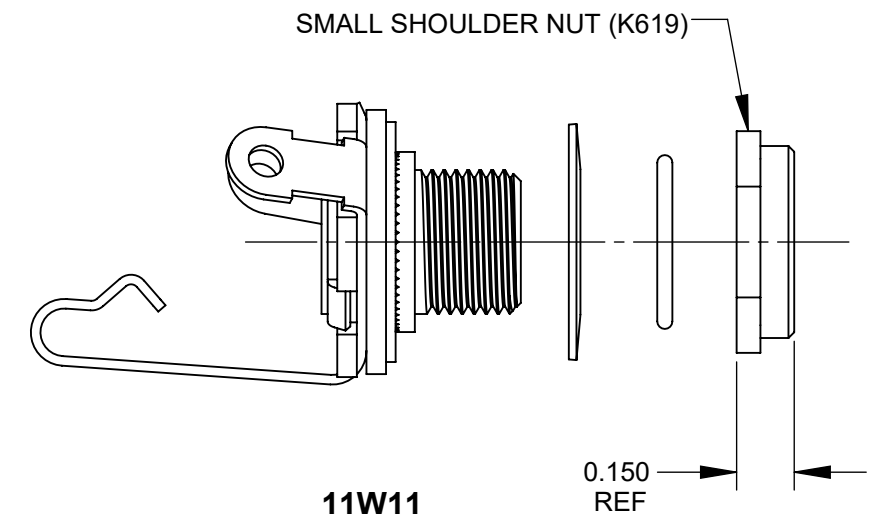
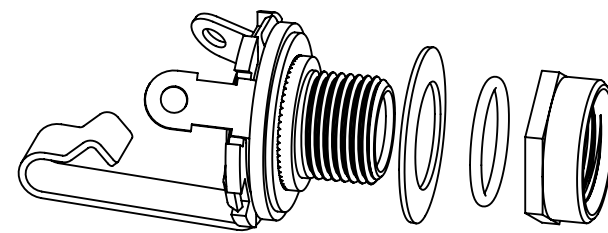

**11W11**  
SEALED JACK  
(WHEN MATED)

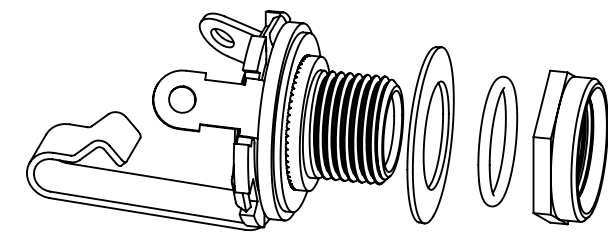

**CUSTOMER DRAWING**

**NOTES:**

- INSTALLATION - SEE THE PANEL THICKNESS AND HARDWARE INSTALLATION TABLE. INSTALL THE JACK AND THE WASHER (IF NEEDED) FROM THE BACK OF THE PANEL. INSTALL THE O-RING AND THEN THE SHOULDER NUT FROM THE FRONT OF THE PANEL. TIGHTEN THE NUT.
- TO BE USED WITH SWITCHCRAFT 250S15-S28 SERIES PLUGS FOR IP66 RATING WHEN MATED.
- RECOMMENDED MOUNTING HOLE:  $\phi 0.375$  [9.5].
- RECOMMENDED WORKING TEMPERATURE: -20 TO 50 °C.
- MATERIALS:  
 BUSHING - BRASS, NICKEL PLATED  
 INSULATING WASHER - PHENOLIC  
 SLEEVE TERMINAL - BRASS, HOT TIN COATED  
 TIP SPRING - NICKEL SILVER  
 O-RING - RUBBER  
 METAL WASHERS - STEEL, NICKEL PLATED  
 SHOULDER NUT - BRASS, NICKEL PLATED
- RoHS COMPLIANT.

REV	ECO NUMBER	DATE	BY	APVD
A	28492	5/18/22	TJK	TJK
REVISIONS				

UNLESS OTHERWISE SPECIFIED

1. ALL DIMENSIONS IN INCHES [mm]  
 - TWO PLACE DECIMALS  $\pm 0.02$  [0.5]  
 - THREE PLACE DECIMALS  $\pm 0.005$  [0.13]

**DO NOT SCALE DRAWING**

THIS DRAWING DESCRIBES A DESIGN CONSIDERED PROPRIETARY IN NATURE, DEVELOPED AND MANUFACTURED BY SWITCHCRAFT INC. AND IS RELEASED ON A CONFIDENTIAL BASIS FOR IDENTIFICATION PURPOSES ONLY.												
SIZE		WIDTH		MULT		LBS/M						
FINISH						MATERIAL						
SPEC No.						SPEC No.						
FIRST USED ON				SCALE				<b>Switchcraft</b> <sup>®</sup>				
				2:1								
DATE DRAWN	BY	CHKD	APVD									
2/17/20	NS	NS	SRC									
				2/17/20	2/17/20			SHEET 1 OF 1				
NAME						PART No.			REV			
SEALED 1/4" MONO JACK, RoHS						11W07-W11			A			