

THIS IS A C.A.D. GENERATED DRAWING
DO NOT MAKE MANUAL REVISIONS TO MASTER.

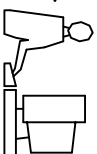

ISSUE NUMBER
ORIGINAL

①

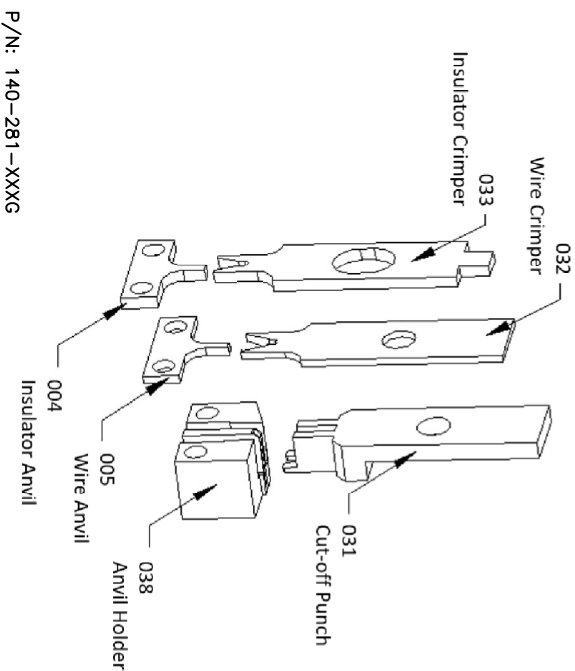
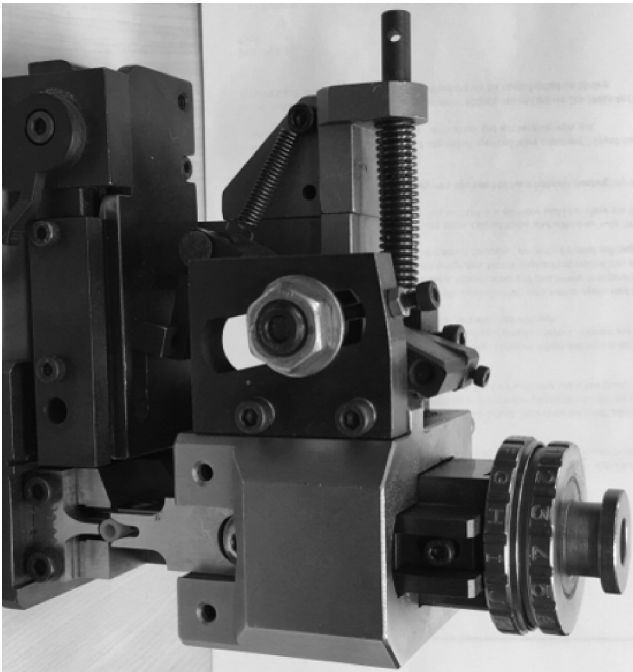

P/N: 140-281-XXXX

PRESS TYPE	G PRESS
STROKE LENGTH	40.00 MM
SHUT HEIGHT	135.79 MM
AWG	24-30

REPLACEMENT PUNCH & DIE PARTS					
INSULATOR ANVIL	WIRE ANVIL	WIRE CRIMPER	INSULATOR CRIMPER	CUT OFF PUNCH	ANVIL HOLDER
140-281-004G	140-281-005G	140-281-032G	140-281-033G	140-281-031G	140-281-038G

NOTES:

- 1- THIS APPLICATOR IS DESIGNED TO BE USED ON A G CRIMPING MACHINE.
- 2- THIS APPLICATOR IS DESIGNED FOR CRIMPING EDAC CONTACT P/N 140-941-290.
- 3- FOR THE DEFINITION OF STROKE LENGTH AND SHUT HEIGHT, APPLICATOR SETUP AND OPERATING INSTRUCTION, PLEASE REFER TO DOCUMENT "APPLICATOR INSTRUCTION MANUAL G PRESS".

140 SERIES APPLICATOR FOR G PRESS

EDAC INC
TORONTO, ONTARIO
CANADA

YOUR CONNECTION TO QUALITY & SERVICE

THESE DRAWINGS AND SPECIFICATIONS ARE THE PROPERTY OF EDAC INC. AND SHALL NOT BE REPRODUCED, OR COPIED OR USED AS THE BASIS FOR THE MANUFACTURE OR SALE OF APPARATUS WITHOUT WRITTEN PERMISSION.

ACAD REFERENCE NO.	140-280-751G
DRAWN:	K.L.
CHECKED:	R.S.M.
SCALE:	N.T.S.
DRAWING NUMBER	140-280-751G
DATE:	OCT.30/2020
DATE:	OCT.30/2020
SHEET	1 OF 1
ISSUE	1