

## Solid-state relay module - PLC-OPT-120UC/230AC/1 - 2900372

Please be informed that the data shown in this PDF Document is generated from our Online Catalog. Please find the complete data in the user's documentation. Our General Terms of Use for Downloads are valid (<http://phoenixcontact.com/download>)



PLC-INTERFACE, consisting of PLC-BPT.../21 basic terminal block with push-in connection and plug-in miniature solid-state relay, for mounting on DIN rail NS 35/7,5, 1 N/O contact, input: 120 V AC/110 V DC, output: 24 - 253 V AC/0.75 A

### Your advantages

- ✓ Slim design
- ✓ Efficient connection to system cabling using V8 adapter
- ✓ RT III sealed solid-state relay
- ✓ Functional plug-in bridges
- ✓ High switching power
- ✓ Zero voltage switch at AC output
- ✓ Integrated input circuit



### Key Commercial Data

Packing unit	10 pc
GTIN	 4 046356 508834
GTIN	4046356508834

### Technical data

#### Note

Utilization restriction	EMC: class A product, see manufacturer's declaration in the download area
-------------------------	---

#### Dimensions

Width	6.2 mm
Height	80 mm
Depth	94 mm

#### Ambient conditions

Ambient temperature (operation)	-25 °C ... 60 °C
Ambient temperature (storage/transport)	-25 °C ... 70 °C

# Solid-state relay module - PLC-OPT-120UC/230AC/1 - 2900372

## Technical data

### Input data

Nominal input voltage $U_N$	120 V AC
	110 V DC
Input voltage range in reference to $U_N$	0.9 ... 1.1
Input voltage range	108 V AC ... 132 V AC
	99 V DC ... 121 V DC
Switching threshold "0" signal in reference to $U_N$	$\leq 0.25$
Switching threshold "1" signal in reference to $U_N$	$\geq 0.8$
Typical input current at $U_N$	4 mA
Typical response time	10 ms (at $U_N$ )
Typical turn-off time	10 ms (at $U_N$ )
Operating voltage display	Yellow LED
Type of protection	Bridge rectifier
Protective circuit/component	Bridge rectifier
Transmission frequency	3 Hz
Power dissipation for nominal condition	0.48 W

### Output data

Output voltage range	24 V AC ... 253 V AC
Limiting continuous current	0.75 A (see derating curve)
Maximum inrush current	30 A (10 ms)
Min. load current	10 mA
Leakage current	< 1 mA (in off state)
Max. load value	4.5 A <sup>2</sup> s
Voltage drop at max. limiting continuous current	< 1 V
Output circuit	2-wire, floating
Type of protection	RCV circuit

### General

Test voltage input/output	2.5 kV (50 Hz, 1 min.)
Mounting position	any
Assembly instructions	In rows with zero spacing
Operating mode	100% operating factor

### Connection data

Connection name	Input side
Connection method	Push-in connection
Stripping length	8 mm
Conductor cross section solid	0.14 mm <sup>2</sup> ... 2.5 mm <sup>2</sup>
Conductor cross section flexible	0.14 mm <sup>2</sup> ... 2.5 mm <sup>2</sup>
Conductor cross section AWG	26 ... 14

### Connection data 2

## Solid-state relay module - PLC-OPT-120UC/230AC/1 - 2900372

### Technical data

#### Connection data 2

Connection name	Output side
Connection method	Push-in connection
Stripping length	8 mm
Conductor cross section solid	0.14 mm <sup>2</sup> ... 2.5 mm <sup>2</sup>
Conductor cross section flexible	0.14 mm <sup>2</sup> ... 2.5 mm <sup>2</sup>
Conductor cross section AWG	26 ... 14

#### Standards and Regulations

Connection in acc. with standard	CUL
Designation	Standards/regulations
Standards/regulations	IEC 60664
	IEC 60664A
	DIN VDE 0110
Insulation	Basic insulation
Pollution degree	2
Overvoltage category	III

#### Environmental Product Compliance

	Lead 7439-92-1
China RoHS	Environmentally Friendly Use Period = 50
	For details about hazardous substances go to tab "Downloads", Category "Manufacturer's declaration"

### Drawings

## Solid-state relay module - PLC-OPT-120UC/230AC/1 - 2900372

Diagram

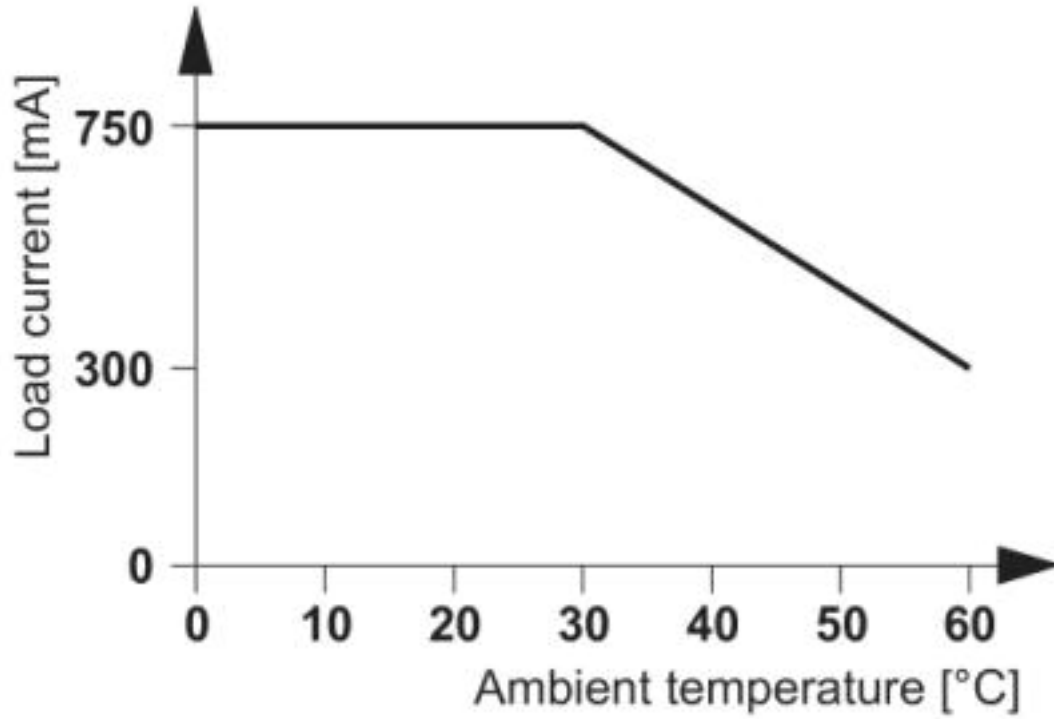

# Solid-state relay module - PLC-OPT-120UC/230AC/1 - 2900372

Circuit diagram

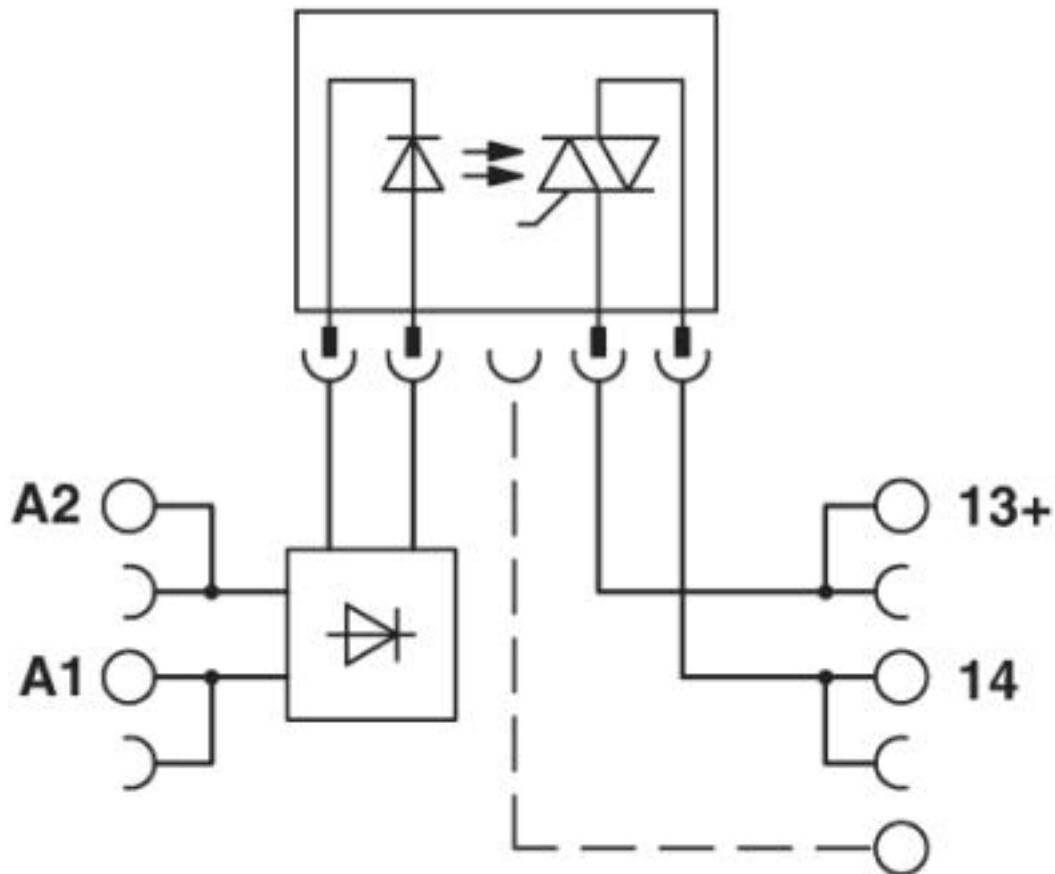

## Approvals

Approvals

Approvals

DNV GL / UL Listed / UL Recognized / cUL Recognized / cUL Listed / EAC / EAC / cULus Recognized / cULus Listed

Ex Approvals

## Approval details

DNV GL



<https://approvalfinder.dnvgl.com/>

TAE0000196-02

# Solid-state relay module - PLC-OPT-120UC/230AC/1 - 2900372

## Approvals

UL Listed		<a href="http://database.ul.com/cgi-bin/XYV/template/LISEXT/1FRAME/index.htm">http://database.ul.com/cgi-bin/XYV/template/LISEXT/1FRAME/index.htm</a>	FILE E 172140
-----------	--	---	---------------

UL Recognized		<a href="http://database.ul.com/cgi-bin/XYV/template/LISEXT/1FRAME/index.htm">http://database.ul.com/cgi-bin/XYV/template/LISEXT/1FRAME/index.htm</a>	FILE E 238705
---------------	--	---	---------------

cUL Recognized		<a href="http://database.ul.com/cgi-bin/XYV/template/LISEXT/1FRAME/index.htm">http://database.ul.com/cgi-bin/XYV/template/LISEXT/1FRAME/index.htm</a>	FILE E 238705
----------------	--	---	---------------

cUL Listed		<a href="http://database.ul.com/cgi-bin/XYV/template/LISEXT/1FRAME/index.htm">http://database.ul.com/cgi-bin/XYV/template/LISEXT/1FRAME/index.htm</a>	FILE E 172140
------------	--	---	---------------

EAC			TR_TS_D_00573_c
-----	--	--	-----------------

EAC			TR_TS_S_00010_c
-----	--	--	-----------------

cULus Recognized			
------------------	--	--	--

cULus Listed			
--------------	--	--	--

Phoenix Contact 2019 © - all rights reserved  
<http://www.phoenixcontact.com>

PHOENIX CONTACT GmbH & Co. KG  
Flachsmarktstr. 8  
32825 Blomberg  
Germany  
Tel. +49 5235 300  
Fax +49 5235 3 41200  
<http://www.phoenixcontact.com>