

GENERAL DRAWING

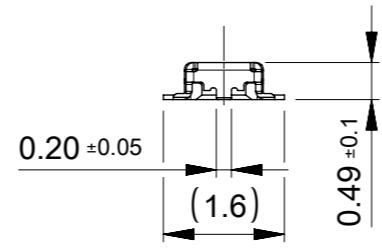
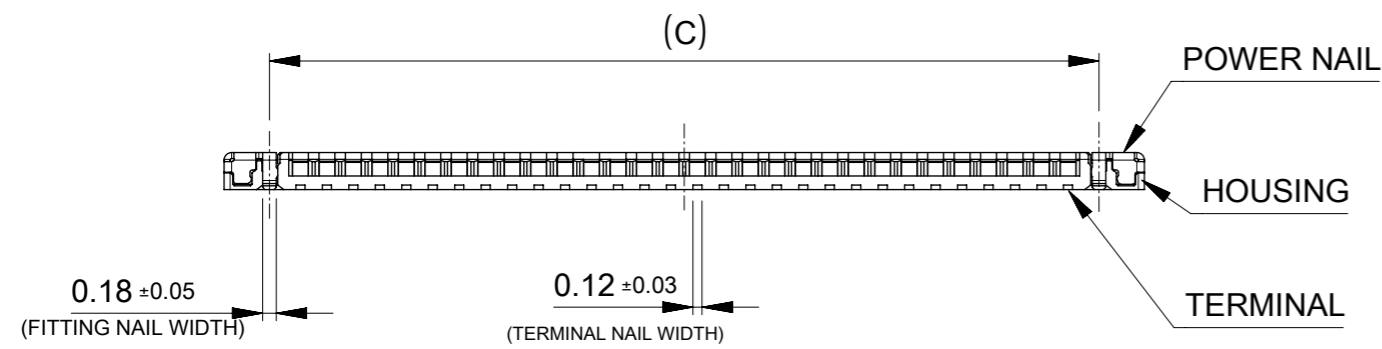
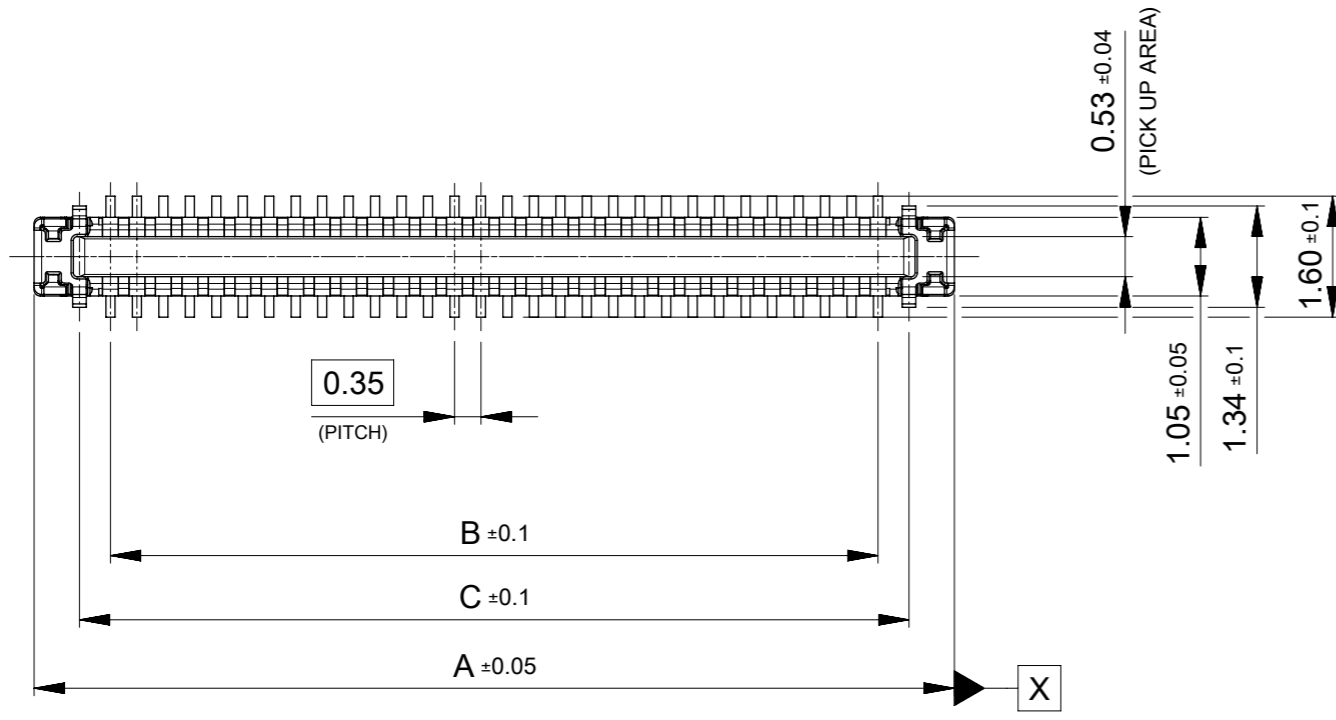

NOTES

- MATERIAL
HOUSING : LIQUID CRYSTAL POLIMER UL94V-0 (COLOR : BLACK)
TERMINAL : COPPER ALLOY
FITTING NAIL : COPPER ALLOY
- PLATING
TERMINAL :
CONTACT AREA : GOLD PLATING(0.1µm MINIMUM)
SOLDER TAIL AREA : GOLD PLATING(0.05µm MINIMUM)
UNDER PLATING : NICKEL OVERALL(1.0µm MINIMUM)
* DIVIED INTO PARTS THE GOLD PLATING OF THE CONTACT AND THE TAIL PART BY THE NICKEL PLATING.
FITTING NAIL :
CONTACT AREA :GOLD PLATING(0.1µm MINIMUM)
SOLDER TAIL AREA : GOLD PLATING(0.05µm MINIMUM)
UNDER PLATING : NICKEL OVERALL(1.0µm MINIMUM)
* DIVIED INTO PARTS THE GOLD PLATING OF THE CONTACT AND THE TAIL PART BY THE NICKEL PLATING.
- MATE WITH : 216700****
- COPLANARITY : SHALL BE 0.08MAX. ON BOTH OF TERMINAL AND NAIL.
AND 0.1 MAXIMUM AFTER REFLOW
- PROHIBITED AREA OF PATTERN WIRING AND SOLDER.
(FOR EACH AREA, THE WIRING THAT TOUCHES ON THE SOLDER CAN BE ATTACHED, THEN COVERED WITH A FILM TO KEEP SOLDER OUT)

10.97	10.15	12.17	2167010609	---	O	60
9.92	9.10	11.12	2167010549	O	---	54
9.22	8.40	10.42	2167010509	O	---	50
7.47	6.65	8.67	2167010409	O	---	40
5.72	4.90	6.92	2167010309	---	O	30
4.67	3.85	5.87	2167010249	---	O	24
3.97	3.15	5.17	2167010209	O	---	20
2.22	1.40	3.42	2167010109	---	O	10
C	B	A	EMBOSSSED TAPE PACKAGE	HIGH VOL. TOOL	LOW VOL. TOOL	Ckts
ORDER No.			SAMPLE PREPARATION			
			O : TOOLED			
			□ : WORK PROCESS			
			--- : TOOLING TO BE CONFIRMED			
CONNECTOR SERIES No. : 2167010***						

FUNCTIONAL SYMBOLS	THIS DRAWING CONTAINS INFORMATION THAT IS PROPRIETARY TO MOLEX ELECTRONIC TECHNOLOGIES, LLC AND SHOULD NOT BE USED WITHOUT WRITTEN PERMISSION		CURRENT REV DESC:		molex		
	mm	10:1					
DIVISIONAL SYMBOLS	GENERAL TOLERANCES (UNLESS SPECIFIED)		EC NO: 746141		0.35 BB CONN H=0.6 ACB6 PLUS PLUG ASSY		
	ANGULAR TOL ± 1.0°		DRWN: DWLEE02 2023/04/14				
4 PLACES ± 0.05		CHK'D: JHCHANG 2023/04/14		PRODUCT CUSTOMER DRAWING			
3 PLACES ± 0.05		APPR: JBJIN 2023/04/17		DOCUMENT NUMBER			
2 PLACES ± 0.05		INITIAL REVISION:		2167010000-SD			
1 PLACE ± 0.1		DRWN: JHCHANG 2023/04/13		DOC TYPE DOC PART REVISION			
0 PLACES ± 0.2		APPR: JBJIN 2023/04/17		PSD 001 A			
DRAFT WHERE APPLICABLE MUST REMAIN WITHIN DIMENSIONS		THIRD ANGLE PROJECTION	DRAWING	SERIES	MATERIAL NUMBER	CUSTOMER	SHEET NUMBER
			A3-SIZE	216701	SEE CHART	GENERAL	1 OF 2

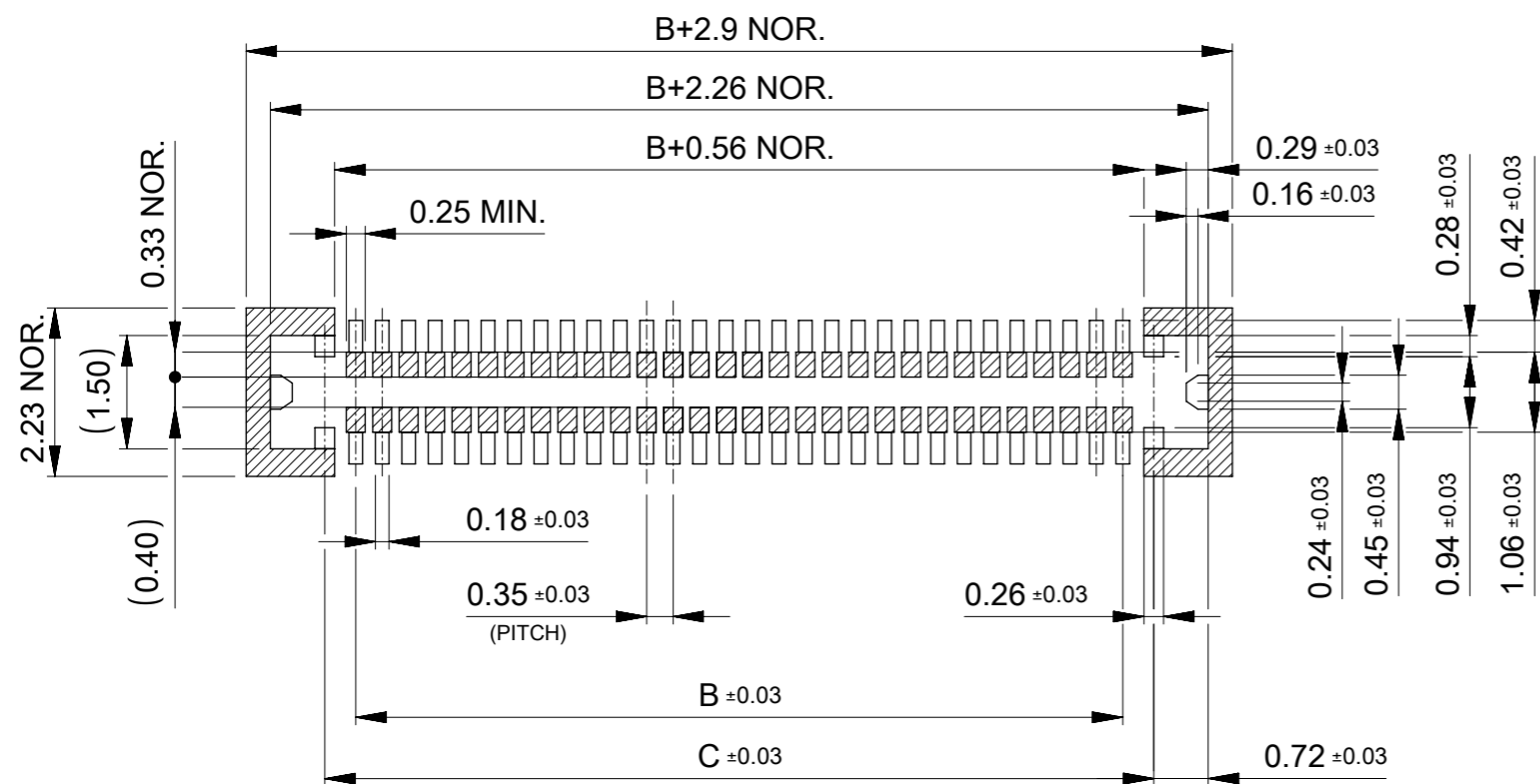

RECOMMENDED P.C.BOARD PATTERN LAYOUT
(FOR REFERENCE)

 SOLDER PROHIBITED AREA.
WHEN WIREING IS LOCATED,
THE WIRING MUST BE MASKED BY COVER LAY OR RESIST FILM.

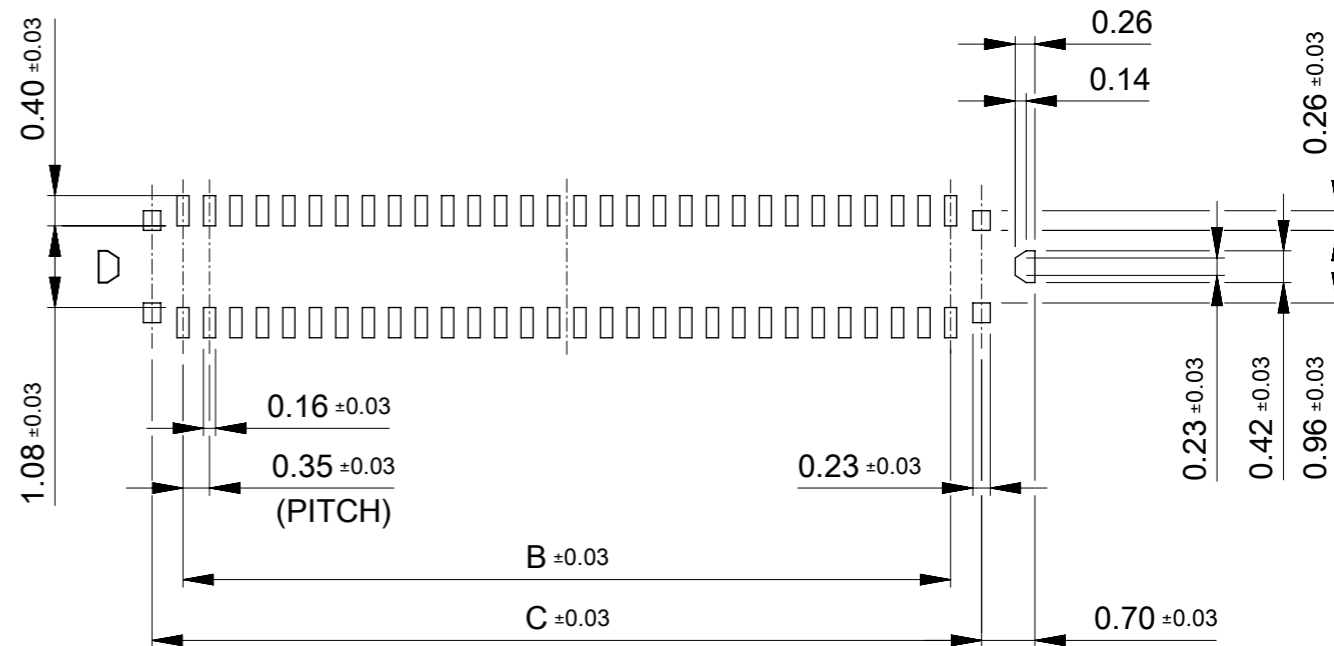

RECOMMENDED METAL MASK LAYOUT
(FOR REFERENCE)

RECOMMENDED THICKNESS : 0.08mm
RECOMMENDED APERTURE DIMENSION IS JUST SAME AS SHOWN FIGURE ABOVE.
FOR THIS DIMENSION, APERTURE RATIO ARE SIGNAL TERMINAL AND
FITTING NAIL ALL 80%.

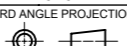
FUNCTIONAL SYMBOLS	THIS DRAWING CONTAINS INFORMATION THAT IS PROPRIETARY TO MOLEX ELECTRONIC TECHNOLOGIES, LLC AND SHOULD NOT BE USED WITHOUT WRITTEN PERMISSION		CURRENT REV DESC:			molex			
	▽A = 0	mm							10:1
DIVISIONAL SYMBOLS	GENERAL TOLERANCES (UNLESS SPECIFIED)		EC NO: 746141 DRWN: DWLEE02 2023/04/14 CHK'D: JHCHANG 2023/04/14 APPR: JBJIN 2023/04/17			PRODUCT CUSTOMER DRAWING			
	▽E = 0	ANGULAR TOL ± 1.0 °							
	▽F = 0	4 PLACES				± 0.05	DOCUMENT NUMBER: 2167010000-SD DOC TYPE: PSD DOC PART: 001 REVISION: A		
		3 PLACES				± 0.05			
		2 PLACES				± 0.05			
	1 PLACE	± 0.1	INITIAL REVISION: DRWN: JHCHANG 2023/04/13 APPR: JBJIN 2023/04/17						
	0 PLACES	± 0.2							
DRAFT WHERE APPLICABLE MUST REMAIN WITHIN DIMENSIONS		THIRD ANGLE PROJECTION	DRAWING	SERIES	MATERIAL NUMBER	CUSTOMER	SHEET NUMBER		
			A3-SIZE	216701	SEE CHART	GENERAL	2 OF 2		

⇒ PULL OUT DIRECTION

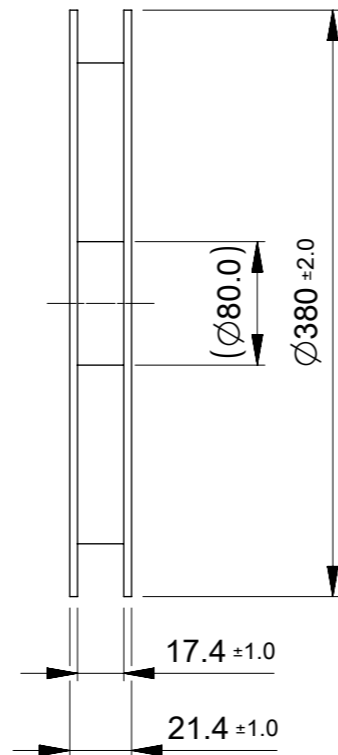
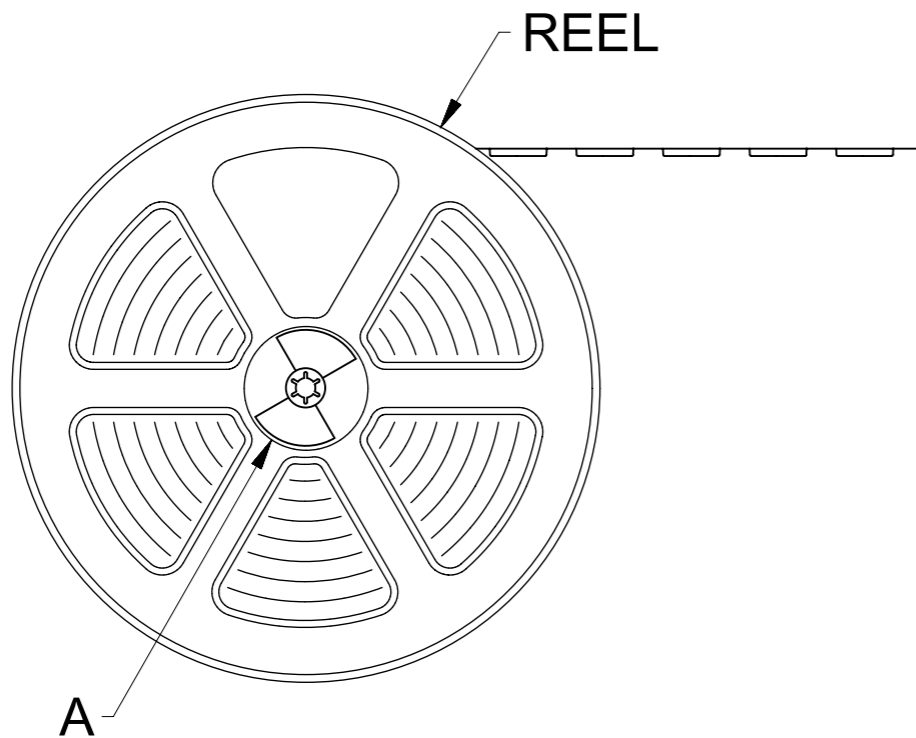

NOTES

1. RE DETAILED DIMENSION, SEE PRODUCT DRAWING.
2. NUMBER OF CONNECTORS : 20,000PCS/REEL
3. LEAD TAPE LENGTH :

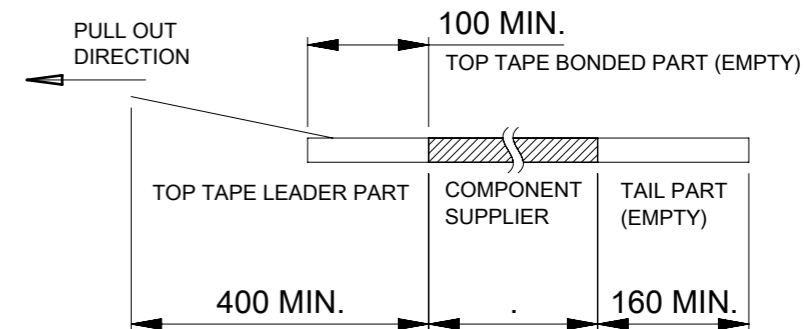

4. PEEL OFF FORCE OF THE TOP TAPE IS DEFINDED BY IEC 60286-3.
5. MATERIAL
 - CARRIER TAPE : POLYSTYRENE OR PET
 - TOP TAPE : PET, OTHER
 - REEL : POLYSTYRENE(PS) [RECYCLE MATERIAL CONTAINED]

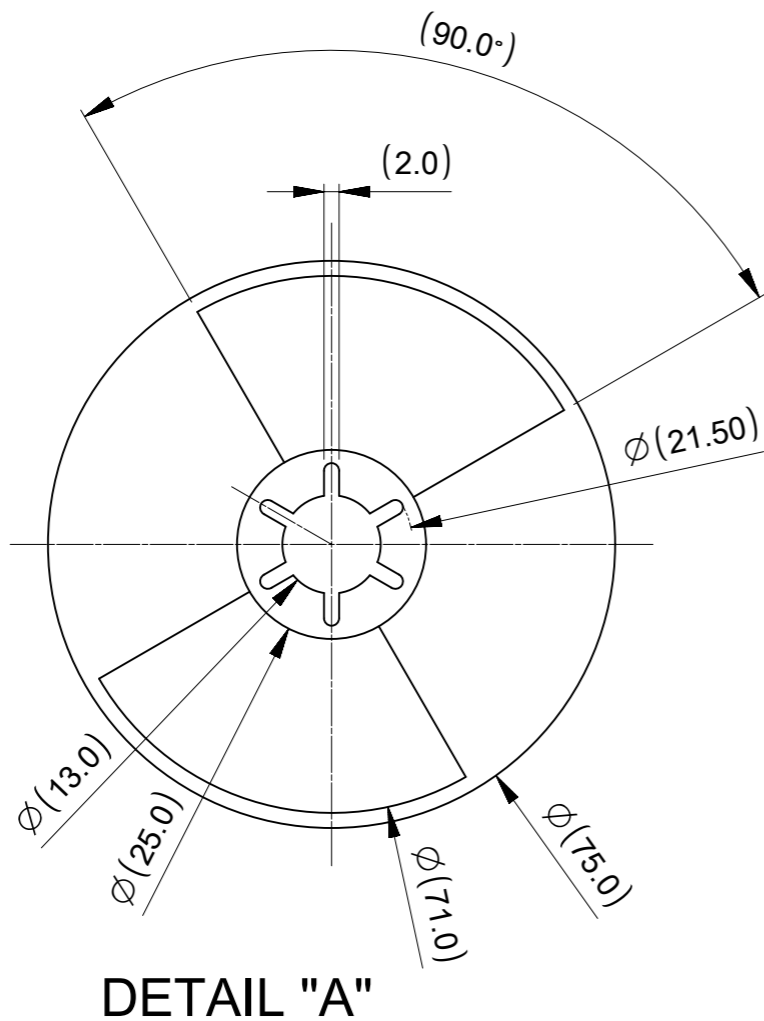

DETAIL "A"

FUNCTIONAL SYMBOLS	THIS DRAWING CONTAINS INFORMATION THAT IS PROPRIETARY TO MOLEX ELECTRONIC TECHNOLOGIES, LLC AND SHOULD NOT BE USED WITHOUT WRITTEN PERMISSION		CURRENT REV DESC:		molex
	DRWN: DWLEE02	2023/04/14	0.35 BB CONN H=0.6 ACB6 PLUS PLUG PKG		
DRWN: JHCHANG	2023/04/14	EC NO: 746141		PRODUCT CUSTOMER DRAWING	
APPR: JBJIN	2023/04/17	DRWN: JHCHANG		DOCUMENT NUMBER	
APPR: JBJIN	2023/04/17	APPR: JBJIN		2167010001-SD	
INITIAL REVISION:	2023/04/13	DRWN: JHCHANG		DOC TYPE	DOC PART
DRWN: JHCHANG	2023/04/17	APPR: JBJIN		PSD	001
APPR: JBJIN	2023/04/17	THIRD ANGLE PROJECTION		REVISION	A
DRAFT WHERE APPLICABLE MUST REMAIN WITHIN DIMENSIONS	THIRD ANGLE PROJECTION	DRAWING	SERIES	MATERIAL NUMBER	CUSTOMER
		A3-SIZE	216701	SEE SHEET2	GENERAL
					SHEET NUMBER
					1 OF 2

PULL OUT DIRECTION →

EMBOSS CARRIER TAPE

TOP TAPE

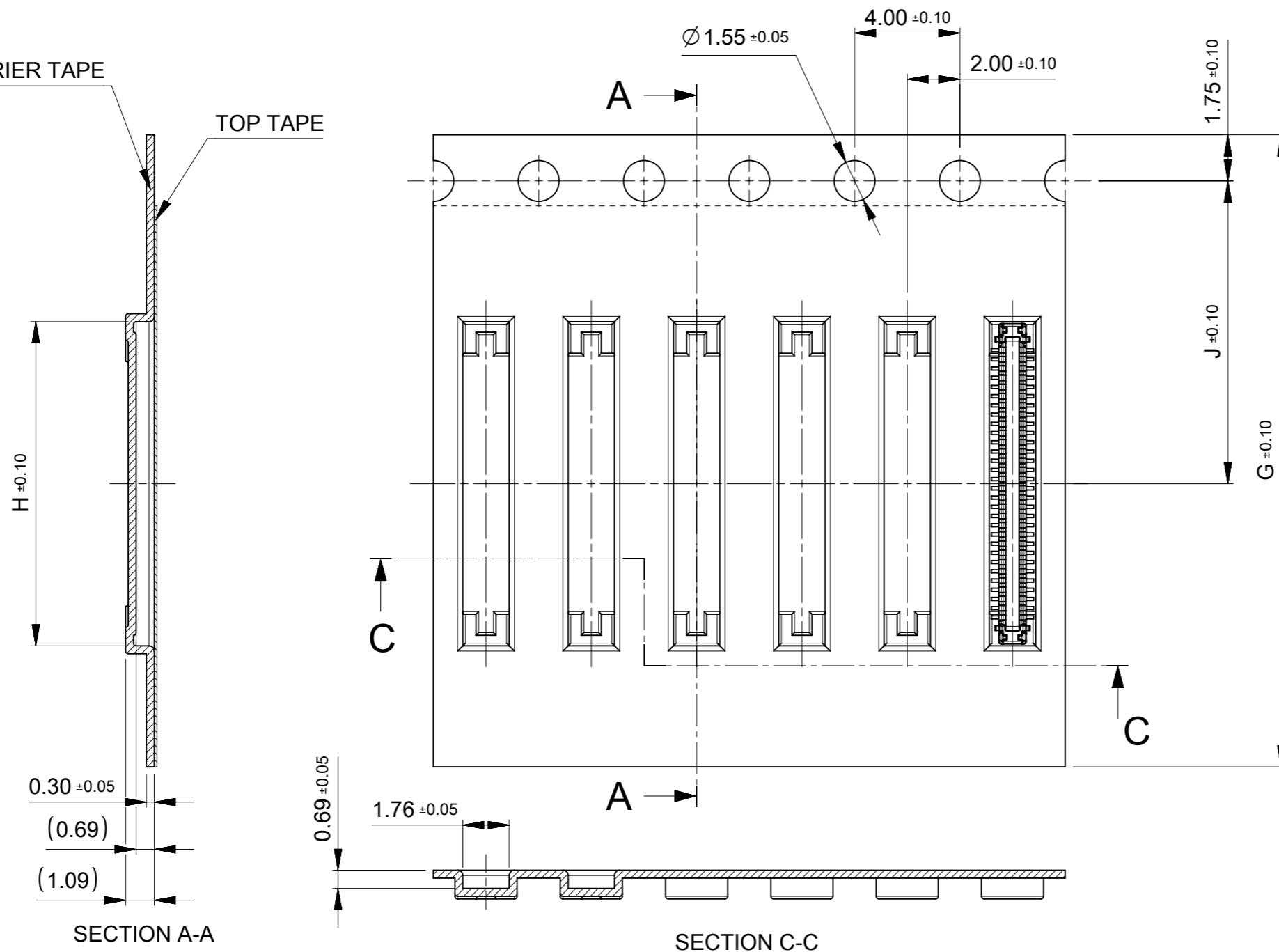

SECTION A-A

SECTION C-C

12.31	11.50	24.00	2167010609	---	O	60
11.26			2167010549	O	---	54
10.56			2167010509	O	---	50
8.81	9.25	16.00	2167010409	O	---	40
7.06			2167010309	---	O	30
6.01			2167010249	---	O	24
5.34			2167010209	O	---	20
3.56			2167010109	---	O	10
H	J	G	EMBOSSED TAPE PACKAGE	HIGH VOL. TOOL	LOW VOL. TOOL	Ckts
ORDER No.			SAMPLE PREPARATION			
			O : TOOLED			
			□ : WORK PROCESS			
			--- : TOOLING TO BE CONFIRMED			
CONNECTOR SERIES No. : 216701****						

FUNCTIONAL SYMBOLS	THIS DRAWING CONTAINS INFORMATION THAT IS PROPRIETARY TO MOLEX ELECTRONIC TECHNOLOGIES, LLC AND SHOULD NOT BE USED WITHOUT WRITTEN PERMISSION	CURRENT REV DESC:		molex																																	
	<table border="1"> <tr> <th>DIMENSION UNITS</th> <th>SCALE</th> </tr> <tr> <td>mm</td> <td>5:1</td> </tr> </table>	DIMENSION UNITS	SCALE		mm	5:1	<table border="1"> <tr> <td colspan="3">GENERAL TOLERANCES (UNLESS SPECIFIED)</td> </tr> <tr> <td>ANGULAR TOL</td> <td>±</td> <td>1.0°</td> </tr> <tr> <td>4 PLACES</td> <td>±</td> <td>0.05</td> </tr> <tr> <td>3 PLACES</td> <td>±</td> <td>0.05</td> </tr> <tr> <td>2 PLACES</td> <td>±</td> <td>0.05</td> </tr> <tr> <td>1 PLACE</td> <td>±</td> <td>0.1</td> </tr> <tr> <td>0 PLACES</td> <td>±</td> <td>0.2</td> </tr> </table>		GENERAL TOLERANCES (UNLESS SPECIFIED)			ANGULAR TOL	±	1.0°	4 PLACES	±	0.05	3 PLACES	±	0.05	2 PLACES	±	0.05	1 PLACE	±	0.1	0 PLACES	±	0.2	<table border="1"> <tr> <td>EC NO: 746141</td> <td>2023/04/14</td> </tr> <tr> <td>DRWN: DWLEE02</td> <td>2023/04/14</td> </tr> <tr> <td>CHK'D: JHCHANG</td> <td>2023/04/17</td> </tr> <tr> <td>APPR: JBJIN</td> <td>2023/04/17</td> </tr> </table>		EC NO: 746141	2023/04/14	DRWN: DWLEE02	2023/04/14	CHK'D: JHCHANG	2023/04/17
DIMENSION UNITS	SCALE																																				
mm	5:1																																				
GENERAL TOLERANCES (UNLESS SPECIFIED)																																					
ANGULAR TOL	±	1.0°																																			
4 PLACES	±	0.05																																			
3 PLACES	±	0.05																																			
2 PLACES	±	0.05																																			
1 PLACE	±	0.1																																			
0 PLACES	±	0.2																																			
EC NO: 746141	2023/04/14																																				
DRWN: DWLEE02	2023/04/14																																				
CHK'D: JHCHANG	2023/04/17																																				
APPR: JBJIN	2023/04/17																																				
DIVISIONAL SYMBOLS	<table border="1"> <tr> <td>INITIAL REVISION:</td> <td>2023/04/13</td> </tr> <tr> <td>DRWN: JHCHANG</td> <td>2023/04/17</td> </tr> <tr> <td>APPR: JBJIN</td> <td></td> </tr> </table>		INITIAL REVISION:	2023/04/13	DRWN: JHCHANG	2023/04/17	APPR: JBJIN		<table border="1"> <tr> <td>DOCUMENT NUMBER</td> <td>DOC TYPE</td> <td>DOC PART</td> <td>REVISION</td> </tr> <tr> <td>2167010001-SD</td> <td>PSD</td> <td>001</td> <td>A</td> </tr> </table>		DOCUMENT NUMBER	DOC TYPE	DOC PART	REVISION	2167010001-SD	PSD	001	A																			
INITIAL REVISION:	2023/04/13																																				
DRWN: JHCHANG	2023/04/17																																				
APPR: JBJIN																																					
DOCUMENT NUMBER	DOC TYPE	DOC PART	REVISION																																		
2167010001-SD	PSD	001	A																																		
<table border="1"> <tr> <td>DRAFT WHERE APPLICABLE MUST REMAIN WITHIN DIMENSIONS</td> <td>THIRD ANGLE PROJECTION</td> <td>DRAWING</td> <td>SERIES</td> <td>MATERIAL NUMBER</td> <td>CUSTOMER</td> <td>SHEET NUMBER</td> </tr> <tr> <td></td> <td></td> <td>A3-SIZE</td> <td>216701</td> <td>SEE SHEET2</td> <td>GENERAL</td> <td>2 OF 2</td> </tr> </table>		DRAFT WHERE APPLICABLE MUST REMAIN WITHIN DIMENSIONS	THIRD ANGLE PROJECTION	DRAWING	SERIES	MATERIAL NUMBER	CUSTOMER	SHEET NUMBER			A3-SIZE	216701	SEE SHEET2	GENERAL	2 OF 2																						
DRAFT WHERE APPLICABLE MUST REMAIN WITHIN DIMENSIONS	THIRD ANGLE PROJECTION	DRAWING	SERIES	MATERIAL NUMBER	CUSTOMER	SHEET NUMBER																															
		A3-SIZE	216701	SEE SHEET2	GENERAL	2 OF 2																															