

customer manual

SAFETY PRECAUTIONS	READ THIS FIRST !	2
1. INTRODUCTION		3
2. PRODUCT-TO-TOOLING CROSS-REFERENCE		5
3. OPERATING INSTRUCTIONS		
3.1. Pre-Operation Check		5
3.2. Mandrel Installation		6
3.3. Product Loading and Unloading		6
3.4. General Operating Procedure		8
4. ADJUSTMENTS		
4.1. Clip Positioning Adjustment		10
4.2. Clip Positioning Assembly Adjustment		10
4.3. Insulation Stripping Adjustment		11
4.4. Push Rod Adjustment		11
5. PREVENTIVE MAINTENANCE AND INSPECTION		
5.1. Lubrication		13
5.2. Inspection		14
6. TROUBLESHOOTING		15
7. REPLACEMENT AND REPAIR		16
7.1. Mandrel Replacement		20
7.2. Push Rod Replacement		20
8. REVISION SUMMARY		21



SAFETY PRECAUTIONS AVOID INJURY

Safeguards are designed into this application equipment to protect operators and maintenance personnel from most hazards during equipment operation. However, certain safety precautions must be taken by the operator and repair personnel to avoid personal injury, as well as damage to the equipment. For best results, application equipment must be operated in a dry, dust-free environment. Do not operate equipment in a gaseous or hazardous environment.

Carefully observe the following safety precautions before and during operation of the equipment:

- ALWAYS wear appropriate ear protection.
- ALWAYS wear approved eye protection when operating powered equipment.
- ALWAYS keep guard(s) in place during normal operation.
- ALWAYS insert power plug into a properly grounded receptacle to avoid electrical shock.
- ALWAYS turn off the main power switch and disconnect electrical cord from the power source when performing maintenance on the equipment.
- NEVER wear loose clothing or jewelry that may catch in moving parts of the application equipment.
- NEVER insert hands into installed application equipment.
- NEVER alter, modify, or misuse the application equipment.

TOOLING ASSISTANCE CENTER

CALL TOLL FREE 1-800-722-1111 (CONTINENTAL UNITED STATES AND PUERTO RICO ONLY)

The **Tooling Assistance Center** offers a means of providing technical assistance when required.

In addition, Field Service Engineers are available to provide assistance in the adjustment or repair of the application equipment when problems arise which your maintenance personnel are unable to correct.

INFORMATION REQUIRED WHEN CONTACTING THE TOOLING ASSISTANCE CENTER

When calling the Tooling Assistance Center regarding service to equipment, it is suggested that a person familiar with the device be present with a copy of the manual (and drawings) to receive instructions. Many difficulties can be avoided in this manner.

When calling the Tooling Assistance Center, be ready with the following information:

1. Customer name
2. Customer address
3. Person to contact (name, title, telephone number, and extension)
4. Person calling
5. Equipment number (and serial number if applicable)
6. Product part number (and serial number if applicable)
7. Urgency of request
8. Nature of problem
9. Description of inoperative component(s)
10. Additional information/comments that may be helpful

PROPER USE GUIDELINES

Cumulative Trauma Disorders can result from the prolonged use of manually powered hand tools. Hand tools are intended for occasional use and low volume applications. A wide selection of powered application equipment for extended-use, production operations is available.

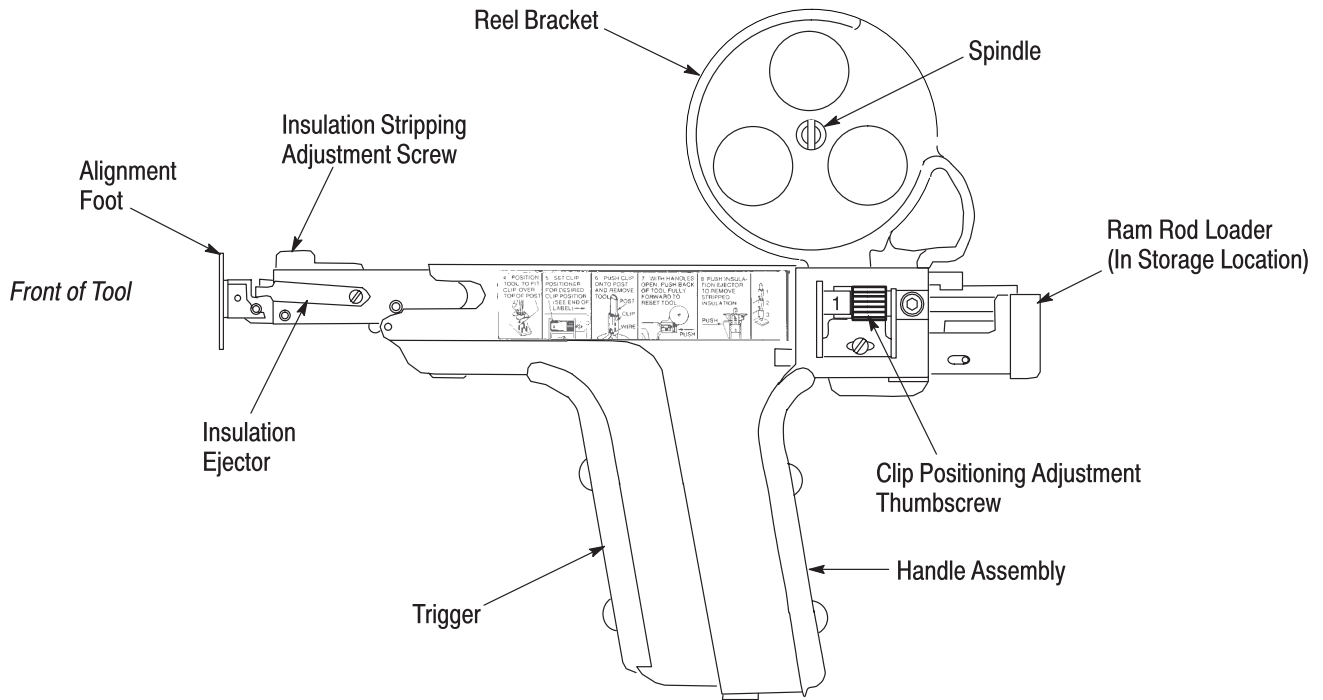

Figure 1

1. INTRODUCTION

TERMI-POINT Tools 69526-2 and 654182-1 (shown in Figure 1) are designed to terminate wires onto rectangular posts with TERMI-POINT clips. These clips are automatically fed from a reel into the tool in continuous strip form.

Read this manual thoroughly before operating the tool. The performance of the tool will depend largely upon the intelligent use of the information contained in this manual.

Reasons for revision to this manual are provided in Section 8, REVISION SUMMARY.

When reading this manual, pay particular attention to **DANGER**, **CAUTION**, and **NOTE** statements.

DANGER Denotes an imminent hazard which may result in moderate or severe injury.



CAUTION Denotes a condition which may result in product or equipment damage.



NOTE Highlights special or important information.



NOTE Dimensions in this manual are in metric units [with U.S. customary units in brackets].



When received, the tool should conform to the dimensions shown in Figure 2.

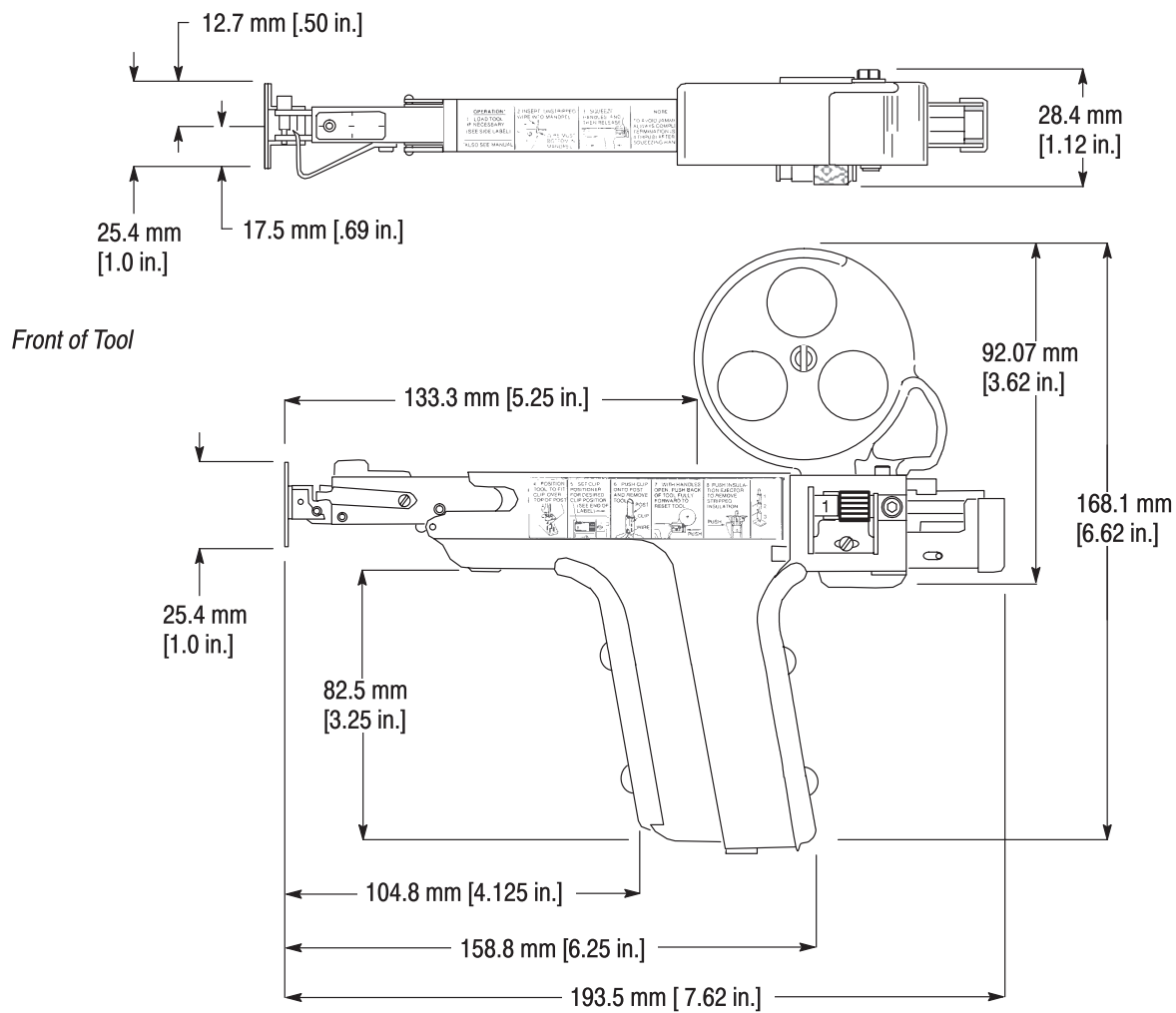

Figure 2

2. PRODUCT-TO-TOOLING CROSS-REFERENCE

These tools use the interchangeable mandrels listed in Figure 3. For product-to-tooling cross-reference, refer to Figure 3.

TOOL	WIRE		MANDREL	CLIP			COLOR CODE (Mandrel and Clip)	
	SIZE (AWG) SOLID OR STRANDED (7 Strands)	INSULATION DIAMETER RANGE (mm [in.])		Reel of 250	Reel of 1000			
					Tin Plated	Gold Plated		Tin-Nickel Plated
69526-2	22	0.99-1.14 [.039-.045]	69551-8	—	6-330495-1	6-330495-2	6-330495-1	Orange
		1.14-1.65 [.045-.065]	1-69411-4					
	24	0.84-1.14 [.033-.045]	69551-9	—	5-330495-3	—	5-330495-3	Red
		1.14-1.65 [.045-.065]	1-69411-3					
	26	0.71-1.14 [.028-.045]	69551-6	—	5-330495-5	—	5-330495-5	Brown
		1.14-1.40 [.045-.055]	1-69411-9					
28	0.61-1.14 [.024-.045]	69551-5	—	5-330495-9	—	5-330495-9	Black	
654182-1	20	1.17-1.65 [.046-.065]	69561	2-330854-5	—	—	—	Yellow
		1.68-2.16 [.066-.085]	69561-1					
	24	1.40-1.65 [.055-.065]	69561-4	3-330854-0	—	—	—	Red

Figure 3

3. OPERATING INSTRUCTIONS

CAUTION

To prevent damage to the tool, avoid unnecessary cycling of an empty tool.



3.1. Pre-Operation Check

Prior to operation be sure to check the following items and make any necessary adjustments to the tool.

1. Be sure that the mandrel is properly installed as described in Paragraph 3.2.
2. Be sure that the tool is properly loaded with product as described in Paragraph 3.3.
3. Be sure that the clip positioning adjustment is set as described in Paragraph 4.1, and that the clip positioning assembly adjustment is correct (refer to Paragraph 4.2).
4. Be sure that the insulation stripping adjustment is correct as described in Paragraph 4.3.
5. Be sure that the push rod adjustment is correct (refer to Paragraph 4.4) and the distance between the clip and the mandrel is as specified in Figure 12.

3.2. Mandrel Installation (See Figure 4)

1. Remove the mandrel holding screw and the alignment foot from the front of the tool.
2. Pull the insulation ejector away from the tool to permit installation of the mandrel.
3. Insert the mandrel into the front of the tool so that, when the clips are in the tool, the tail of the mandrel enters the open portion of the first clip.
4. Re-install the the alignment foot and the mandrel holding screw.



Tighten the mandrel holding screw only enough to hold the mandrel in place. Excessive tightening may distort the front of the tool.

5. Align the insulation ejector with the insulation slot of the mandrel.

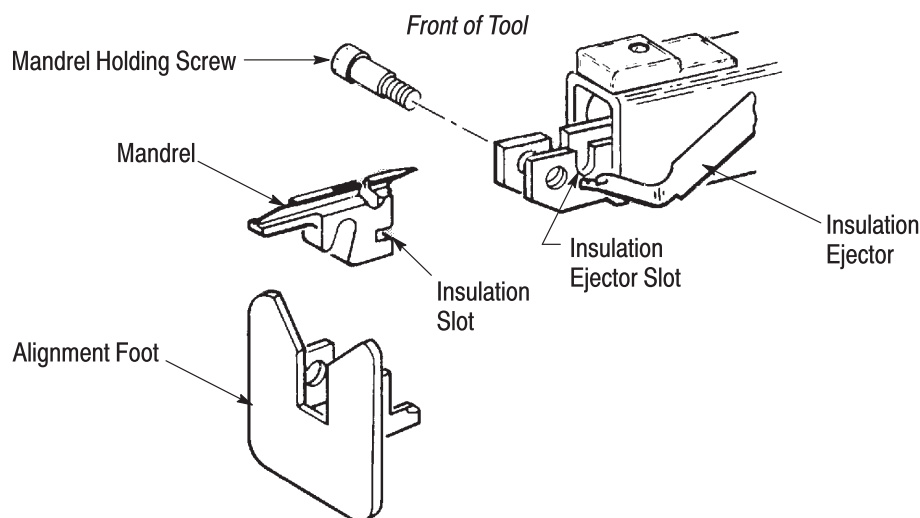

Figure 4

3.3. Product Loading and Unloading

A. Loading

1. Select a full reel of product that corresponds with the tool, mandrel, and wire size being used (refer to Figure 3).
2. Free the exposed end of the clip train on the reel, and place the reel onto the reel bracket with the clips feeding from the bottom of the reel. See Figure 5, Detail A. Ensure that the clips are straight and the insulation supports (strain reliefs) of the clips are “up” and face toward the front of the tool. See Figure 5, Detail B.
3. Insert the clips into the clip feed slot. The insulation support (strain relief) of the clip must be “up” and facing toward the front of the tool. See Figure 5, Detail B.
4. Use the ram rod loader, attached to the cap on the back of the tool, to push clips into the clip feed slot until the strip is visible in the hole in the side of the tool. **DO NOT FORCE THE CLIPS.** See Figure 5, Detail A.
5. Squeeze the trigger, then use the ram rod loader to feed the clips forward until a clip snaps into position behind the mandrel.
6. Return the ram rod loader to the ram rod storage location of the tool. See Figure 5, Detail B.

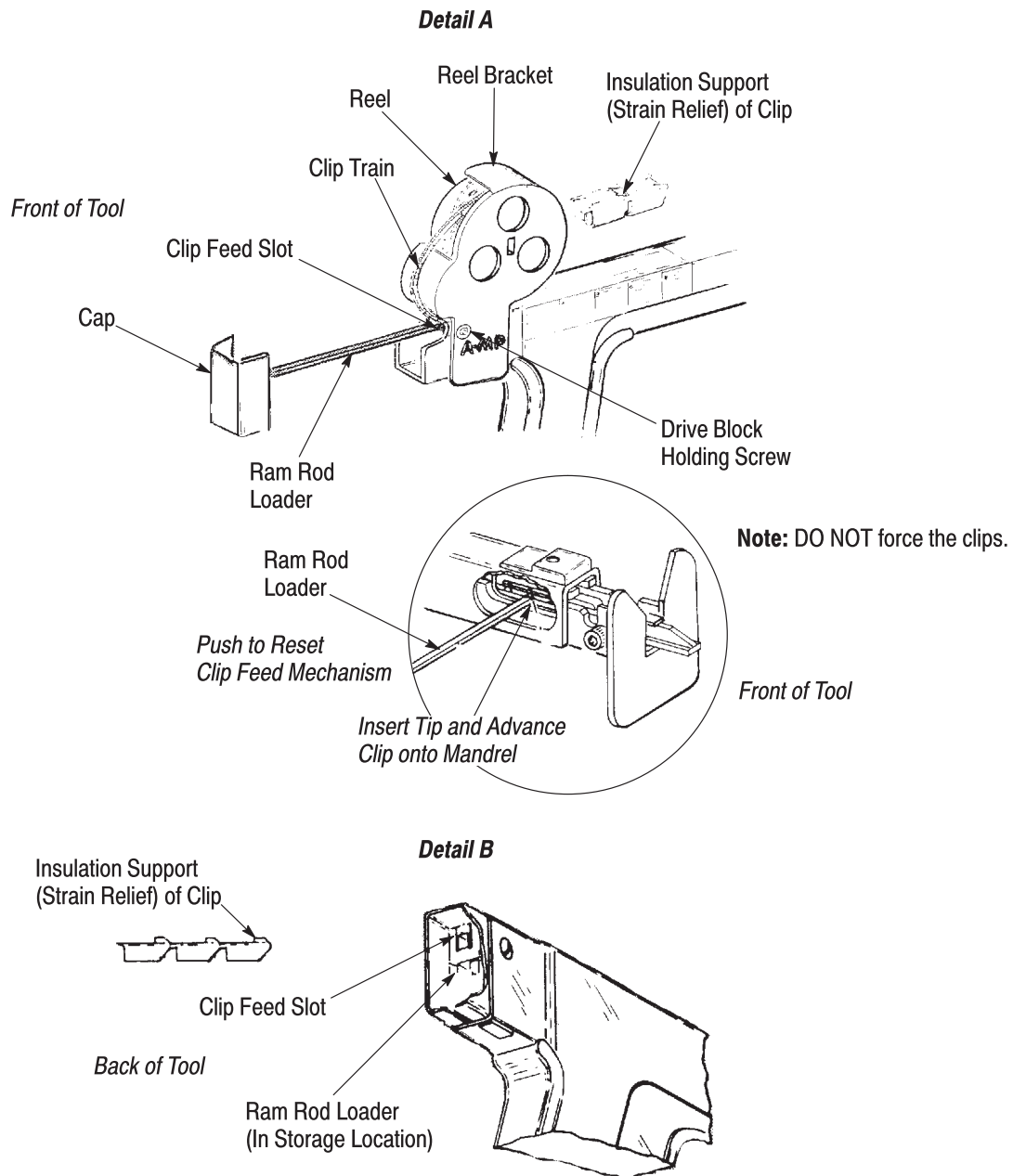

Figure 5

B. Unloading

1. Remove the mandrel.
2. Partially depress the trigger, then push the cap (on the end of the ram rod loader) forward to reset the clip feed mechanism.

NOTE

If the trigger is **fully** depressed, a clip will be cut from the clip train strip.



3. Repeat Step 2 as many times as necessary to remove the unused portion of the clip train from the tool.
4. Re-install the mandrel.

3.4. General Operating Procedure

1. Insert an unstripped wire into the hole in the top of the mandrel. Make sure the wire bottoms in the mandrel. See Figure 6.

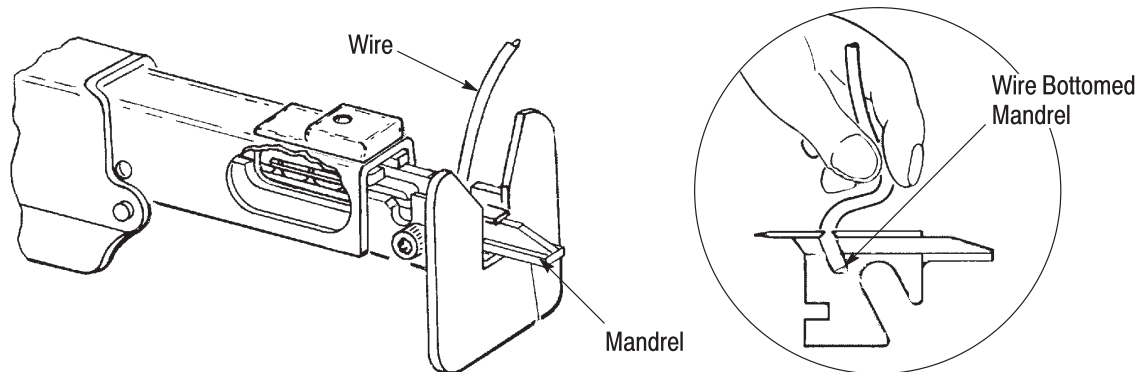

Figure 6

2. Slowly squeeze the trigger until it bottoms against the handle, then release the trigger. The clip is now ready to be applied to the post.
3. Hold the tool perpendicular to the panel, and slip the exposed clip over the end of the post. See Figure 7.

NOTE



The alignment foot should rest on the post(s) to aid in maintaining both vertical and horizontal alignment of the tool with the post(s).

4. Grip the tool lightly, then push, using a steady even pressure until the clip reaches the desired position on the post.

CAUTION



Always complete a termination after the trigger has been depressed. If the tool is reset and the trigger is depressed a second time without completing a termination, two clips will be fed onto the mandrel, causing a jam.

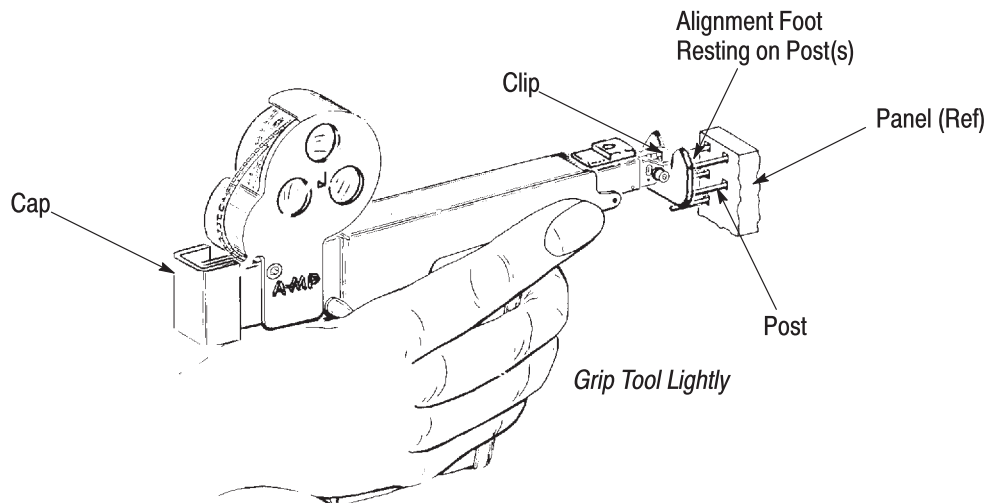

Figure 7

CAUTION

DO NOT attempt to terminate a post that has been previously terminated.



5. Remove the tool from the post. A properly terminated post should appear as shown in Figure 8. Be certain that stripped conductor, *not* the insulation, is visible at the back end of the clip.

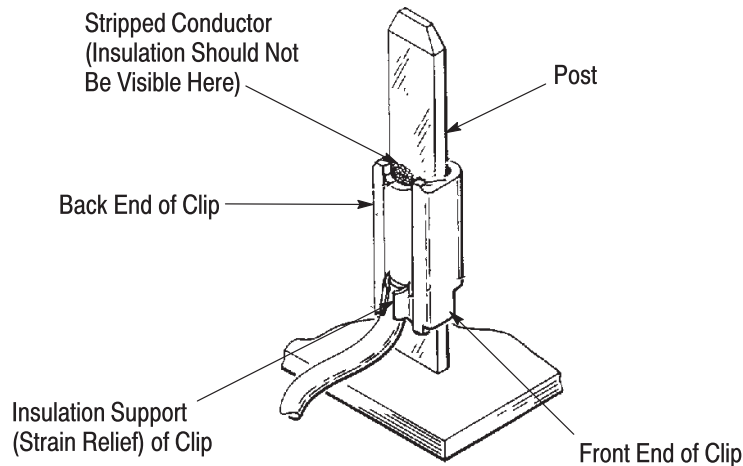

Figure 8

6. With the trigger released, push the cap (refer to Figure 7) fully forward to reset the tool for the next termination.

7. Push the insulation ejector to remove the stripped insulation from the tool before inserting the next wire. Refer to Figure 9.

8. Repeat Steps 1 through 6 for the next termination.

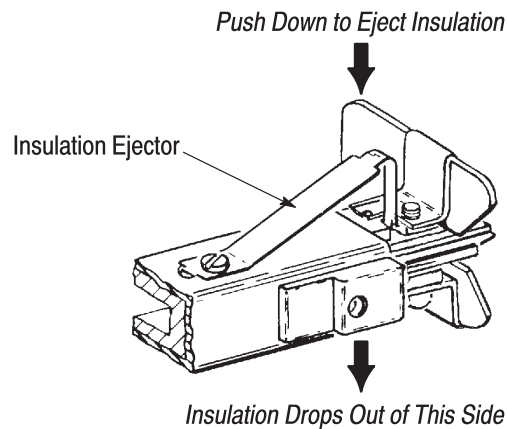

Figure 9

4. ADJUSTMENTS

4.1. Clip Positioning Adjustment (Figure 10)

The clip positioning assembly adjustment controls the position of the clip when it is applied to the post. When applying three clips to a post, first set the positioning adjustment to “3”. This positions the first clip at the bottom of the post. Then set the positioning adjustment to the “2” setting to place the second clip in the middle of the post. Finally, set the positioning adjustment to “1” to position the third clip on the top of the post. When applying two clips to a post, begin with the “2” setting, and when applying one clip to a post, use the “1” setting. Use the following procedure to make an adjustment.

1. Refer to Figure 10 to determine the maximum number of clips to be applied to a post.
2. Rotate the clip positioning adjustment thumbscrew so that the desired setting appears, as shown in Figure 10. Figure 10 indicates the maximum number of clips to be applied to a post. If less than the maximum is desired (i.e., two clips on a three-clip post, allowing space at the bottom for wire routing), adjust the setting to the number required. The tool is now ready to apply clips.

NOTE If the clip positioning assembly requires adjustment, refer to Paragraph 4.2, *Clip Positioning Assembly Adjustment*.



Clip Positioning Adjustment Setting

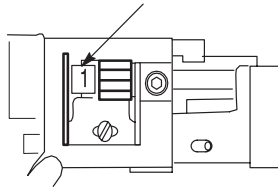

MINIMUM POST HEIGHT (mm [in.])		MAXIMUM NUMBER OF CLIPS TO BE APPLIED
TOOL 69526-2	TOOL 654182-1	
8.60 [.34]	12.70 [.50]	1
13.70 [.54]	19.05 [.75]	2
18.80 [.74]	25.40 [1.0]	3

Figure 10

4.2. Clip Positioning Assembly Adjustment

Each tool has an adjustment to control the the distance travelled by the first clip onto a post. These tools are preset at the factory and should require no further adjustment. However, adjustment may be necessary when replacing the push rod. Adjust the clip position as follows:

1. Loosen the clip positioning assembly adjustment screws. Refer to Figure 11.
2. Slide the clip positioning assembly toward the *back* of the tool to *increase* the distance travelled by the clip or slide the clip positioning assembly toward the *front* of the tool to *decrease* the distance travelled by the clip.
3. Gradually, move the clip positioning assembly, tighten the adjustment screws, and make test terminations to check the clip position.
4. Repeat Steps 2 and 3 until the required position is achieved.

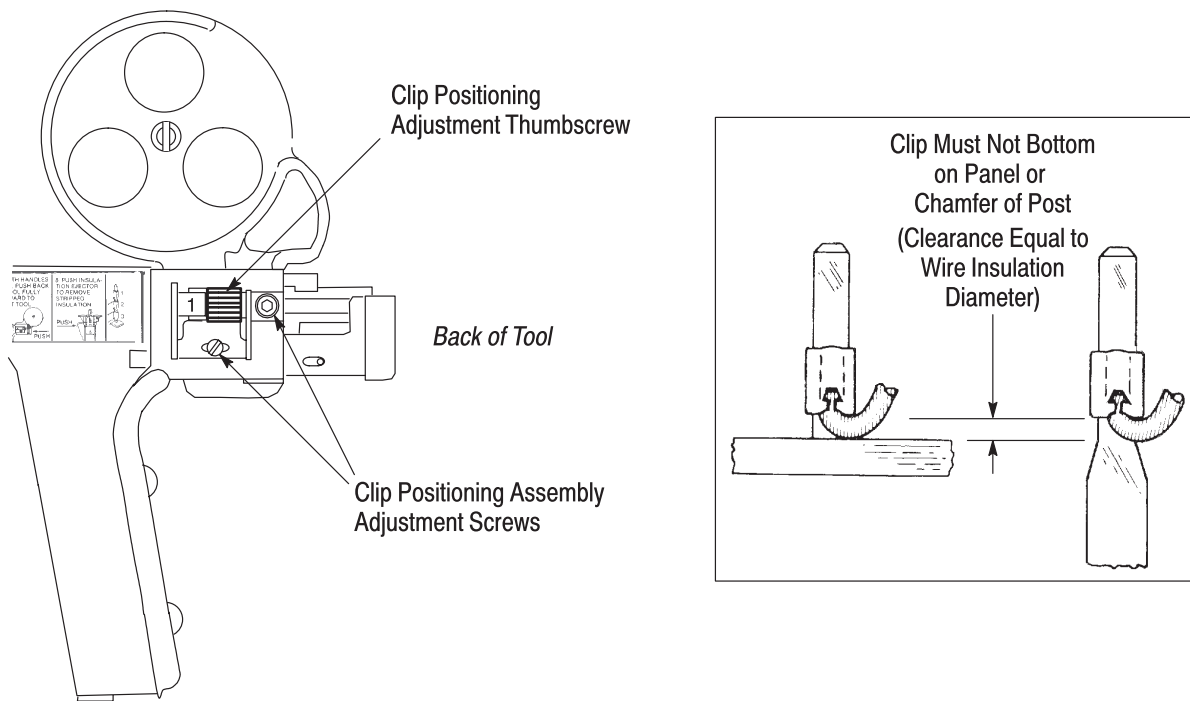

Figure 11

4.3. Insulation Stripping Adjustment

Each tool has an adjustment (shown in Figure 1) to control the stripping action provided when the push rod forces the clip over the mandrel. These tools are set at the factory and should not require adjustment. However, if the tool is not stripping the wire properly (i.e., nicked conductor strands or insulation not stripped from the wire), adjust the tool as follows:

1. Turn the insulation stripping adjustment screw *clockwise to increase* the strip depth, or *counterclockwise to decrease* the strip depth.
2. Make a test termination to check the stripping action.
3. Repeat Steps 1 and 2 until the desired stripping action is obtained.

4.4. Push Rod Adjustment

The push rod can be adjusted to control the amount of travel during clip application. The tools are set at the factory and the push rod should not normally require further adjustment. However, if improper feed or positioning occurs, or if the push rod has been replaced, perform the following check and make the adjustment as required.

Check the push rod adjustment as follows:

1. With the tool loaded, squeeze and hold the handle to keep the push rod fully extended onto the mandrel.
2. With the push rod fully extended, measure the distance from the front of the clip to the front of the mandrel. If the dimension is not within the range specified in Figure 12, adjustment is required.

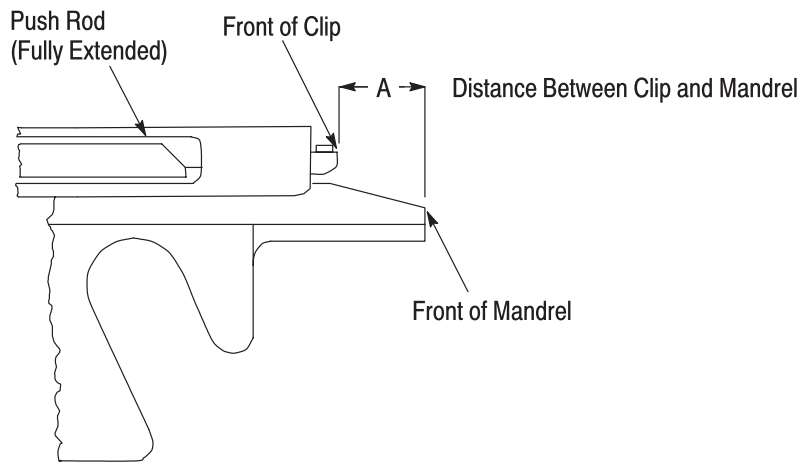

TOOL	DIMENSION A (mm [in.])
69526-2	1.5-2.3 [.060-.090]
654182-1	2.7-3.5 [.105-.140]

Figure 12

Adjust the push rod as follows:

1. Remove the loading tool, break the clip train strip as it enters the back of the tool, and remove the reel bracket.
2. Loosen the clip positioning assembly adjustment screw behind the clip positioning adjustment thumbscrew. See Figure 11.
3. Move the push rod forward or backward as required to obtain the required dimension given in Figure 12.
4. Tighten the clip positioning assembly adjustment screw behind the clip positioning adjustment thumbscrew. See Figure 11.
5. Re-install the reel bracket and the loading tool.
6. Push the cap forward to reset the tool. The tool is now ready for operation. Use the clips remaining on the strip inside the tool and reload the tool with a clip strip from the reel. Refer to Paragraph 3.3.

5. PREVENTIVE MAINTENANCE AND INSPECTION

5.1. Lubrication

A periodic lubrication schedule, using any good grade SAE 20 motor oil, should be maintained at the intervals specified in Figure 13.

1. Squeeze the tool handles to expose the push rod.
2. Apply a light coat of lubricant to the top of the push rod.

CAUTION *DO NOT allow the lubricant to contact the clips or clip contact surfaces (such as the mandrel).*



3. Lubricate the tool body in the areas shown in Figure 13.

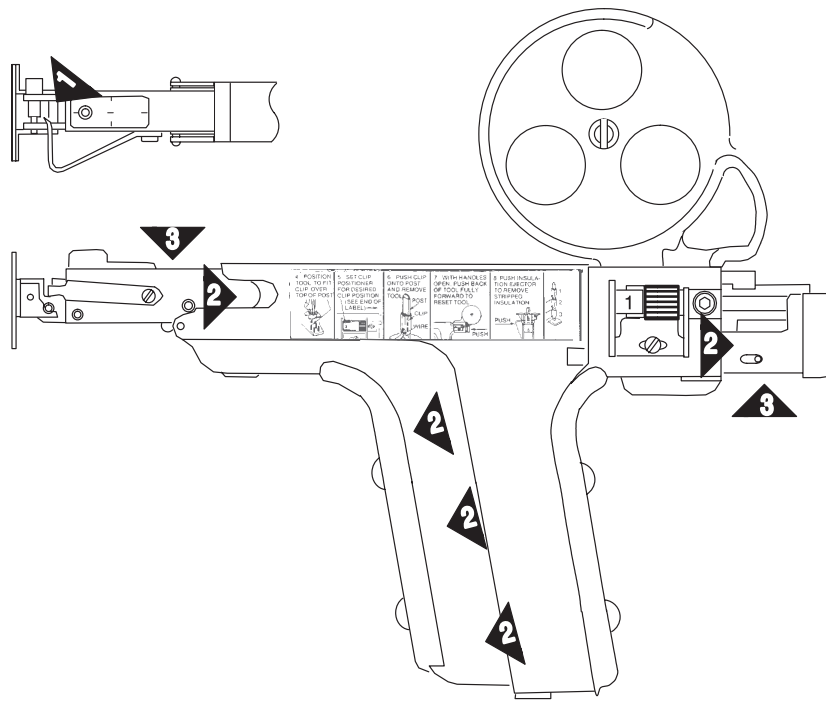

AREA	LOCATION	LUBRICATION INTERVAL
Top of Push Rod	1	Every 500 Terminations
Both Side of Tool Body	2	Every 1000 Terminations
Top and Bottom of Tool Body	3	Every 1000 Terminations

Figure 13

5.2. Inspection

The following items should be checked periodically to ensure proper operating efficiency of the tooling.

1. Be certain the screws (Figure 17, Items 14, 15, 20, and 21) are tight.
2. Clean the tool and remove insulation scraps on a regular basis.
3. When the tool is cycled to apply clips, observe the operation of the tool. If binding of moving parts is noted, lubricate the tool as described in Paragraph 5.1.
4. Check the mandrel for nicks and burrs. Refer to Figure 14. Nicks and burrs on the mandrel can cause clip jams and damage to other related parts.
 - a. Remove the mandrel and mandrel tail or anvil clip from the tool.
 - b. Use a magnifying glass or a fingernail to detect the location of nicks and burrs.

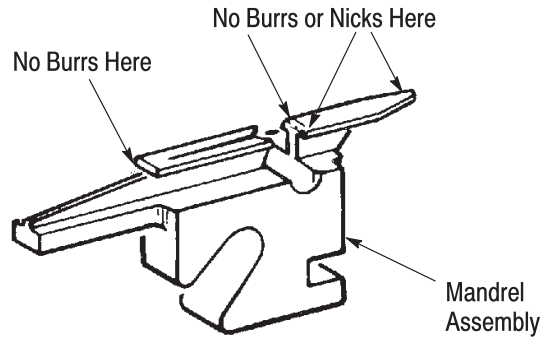

Avoid the following causes for nicks and burrs on the mandrel:

- Cycling the tool continuously without clips installed.
- Inserting a scribe or sharp object in the stripping groove area to remove stripped insulation
- Using a scribe or sharp object improperly to remove the jammed clips from the mandrel
- Inserting a scribe or sharp object in the stripping groove area to remove the mandrel from the tool
- Cycling the tool continuously with clips jammed on the mandrel

Figure 14

If necessary, remove the nicks and burrs using a suitable oil stone, grind the burrs off the exterior edges of the mandrel. Then clean the repaired parts and install them in the tool.



Always move the oil stone lengthwise along the mandrel. See Figure 15.

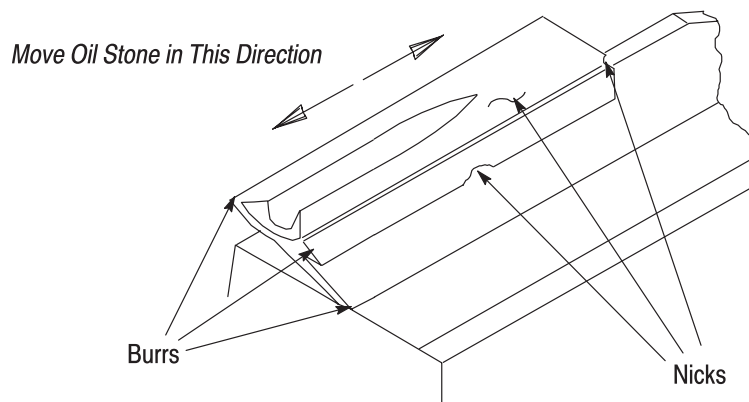

Figure 15

6. TROUBLESHOOTING

Every tool is thoroughly inspected before leaving the factory and should be in perfect operating condition when it reaches the customer. If, at anytime, the tool does not function properly, refer to Figure 16.

SYMPTOM	POSSIBLE CAUSE	REMEDY
Clips do not feed from the tool.	Clips are not properly seated in the tool.	Refer to Paragraph 3.3.,A., Loading.
	Incorrect clip or mandrel is being used.	Be certain that the proper clip, mandrel, and wire combination is being used. Refer to Figure 3.
	The push rod is broken or bent.	Refer to Paragraph 7.2., Push Rod Replacement and Paragraph 4.4., Push Rod Adjustment.
	The push rod is riding over the clips.	Correct the insulation stripping adjustment. Refer to Paragraph 4.5.
	The clip train is broken.	Refer to Paragraph 3.3.A., Loading.
Clips jam in the tool.	The clip is improperly inserted into the tool.	Refer to Paragraph 3.3.A., Loading.
	Incorrect clip or mandrel is being used.	Be certain that the proper clip, mandrel, and wire combination is being used. Refer to Figure 3.
	Incorrect application is being used.	Refer to Paragraph 3.4., General Operating Procedure.
	The push rod is riding over the clips.	Correct the insulation stripping adjustment. Refer to Paragraph 4.3.
Clips indexed onto the mandrel in a continuous strip.	There is an incomplete cycling of the tool.	Always complete a termination after the trigger has been depressed.
Clip is mangled or distorted when applied to the post.	Incorrect clip or mandrel is being used.	Be certain that the proper clip, mandrel, and wire combination is being used. Refer to Figure 3.
Wire is not stripped cleanly or completely.	Incorrect clip or mandrel is being used.	Be certain that the proper clip, mandrel, and wire combination is being used. Refer to Figure 3.
	The mandrel is worn or broken.	Replace the mandrel as described in Paragraph 7.1.
	The insulation stripping adjustment is incorrect.	Correct the insulation stripping adjustment Refer to Paragraph 4.3.
Wire conductor is nicked or cut.	Incorrect clip, wire, or mandrel is being used.	Be certain that the proper clip, mandrel, and wire combination is being used. Refer to Figure 3.
	The mandrel is worn or broken.	Replace the mandrel as described in Paragraph 7.1.
	The insulation stripping adjustment is incorrect.	Correct the insulation stripping adjustment. Refer to Paragraph 4.3.
Clips do not stack properly.	The clip positioning adjustment is incorrect.	Refer to Paragraph 4.1., Clip Positioning Adjustment.
Clip has low tensile strength.	Incorrect clip, wire, or mandrel is being used.	Be certain that the proper clip, mandrel, and wire combination is being used. Refer to Figure 3.
	The insulation stripping adjustment is incorrect.	Correct the insulation stripping adjustment. Refer to Paragraph 4.3.

Figure 16

7. REPLACEMENT AND REPAIR

Customer-replaceable parts are listed in Figure 17. A complete inventory should be stocked and controlled to prevent lost time when replacement of parts is necessary. Parts other than those listed should be replaced by Tyco Electronics to ensure quality and reliability. Order replacement parts through your representative, or call 1-800-526-5142, or send a facsimile of your purchase order to 717-986-7605, or write to:

CUSTOMER SERVICE (038-035)
 TYCO ELECTRONICS CORPORATION
 PO BOX 3608
 HARRISBURG PA 17105-3608

For customer repair service, call 1-800-526-5136.

REPLACEMENT PARTS				
ITEM	PART NUMBER		DESCRIPTION	QTY PER TOOL
	69526-2 (Detail A)	654182-1 (Detail B)		
1	265321-1	—	GUIDE BLOCK	1
2	—	239752-1	GUIDE, Rib Support	1
3	241385	239492-1	GUIDE, Rib	1
4	241395-2	239484-1	PUSH ROD ASSEMBLY	1
5	265323-1	—	DRIVE BLOCK	1
6	—	239480-1	PLATE, Drive Block Assembly	1
7	—	239494	PLATE, Push Rod	1
8	265577-1	239487-1	BODY ASSEMBLY	1
9	239663	241451-1	BODY	1
10	21028-5	21028-5	PIN, Roll, .062 in. × .437 in. L	3
11	21028-6	21028-6	PIN, Roll, .062 in. × .50 in. L	1
12	265501-1	265501-1	PIN, Spiral, .062 in. × .375 in. L	3
13	241469	241469	SPRING, Insulation Ejector	1
14	21060-1	21060-1	SCREW, Self-Tapping, No. 2, .125 in. L	2
15	6-21000-4	6-21000-4	SCREW, Mandrel Holding	1
16	265558-1	306535-1	ALIGNMENT FOOT	1
17	265336-1	265336-1	BRACKET, Reel	1
18	265559-1	—	BRACKET, Hold Down	1
19	21078-1	—	SCREW, Socket Set, 4-40 UNC × .125 in. L	1
20	1-21000-3	—	SCREW, Socket Head Cap, 4-40 UNC × .250 in. L	1
21	1-21000-4	—	SCREW, Socket Head Cap, 4-40 UNC × .375 in. L	1
22	2-21986-7	2-21986-7	RING, Retaining	1
23	241470	241470	PIN	1
24	21026-1	21026-1	LOCKWASHER, External Tooth, No. 4	2
25	241477-3	241477-3	LOADER, Ram Rod	1
26	246555-2	246555-3	CLIP POSITIONING ASSEMBLY	1
27	241390	239490	PLATE, Support	2

Figure 17 (Continued)

ITEM	PART NUMBER		DESCRIPTION	QTY PER TOOL
	69526-2 (Detail A)	654182-1 (Detail B)		
28	241382-1	239491	LEVER CATCH, Left	1
29	241382-2	239491	LEVER CATCH, Right	1
30	241394	239495	SPRING, Lever Catch	1
31	241384-4	239489-2	BRACKET, Right	1
32	241384-3	239489-1	BRACKET, Left	1
33	265576-1	239488	SIDE PLATE, Right	1
34	265574-1	239493	SIDE PLATE, Left	1
35	241485-2	241485-2	HANDLE ASSEMBLY, Sliding	1
36	239723-1	239723-1	HANDLE ASSEMBLY, Fixed	1
37	2-305786-0	2-305786-0	LABEL	1
38	—	1-21000-5	SCREW, Socket Head Cap	1
39	—	8-22140-6	SCREW, Socket Head Cap	1
40	—	240447-1	SCREW, Socket Head Cap, 4-40 UNC × .128 in. L	1
41	—	240413-2	SPACER	2
42	—	21055-4	SPACER	2
43	Refer to Figure 18		MANDREL	1

Figure 17 (Continued)

Detail A — Tool 69526-2

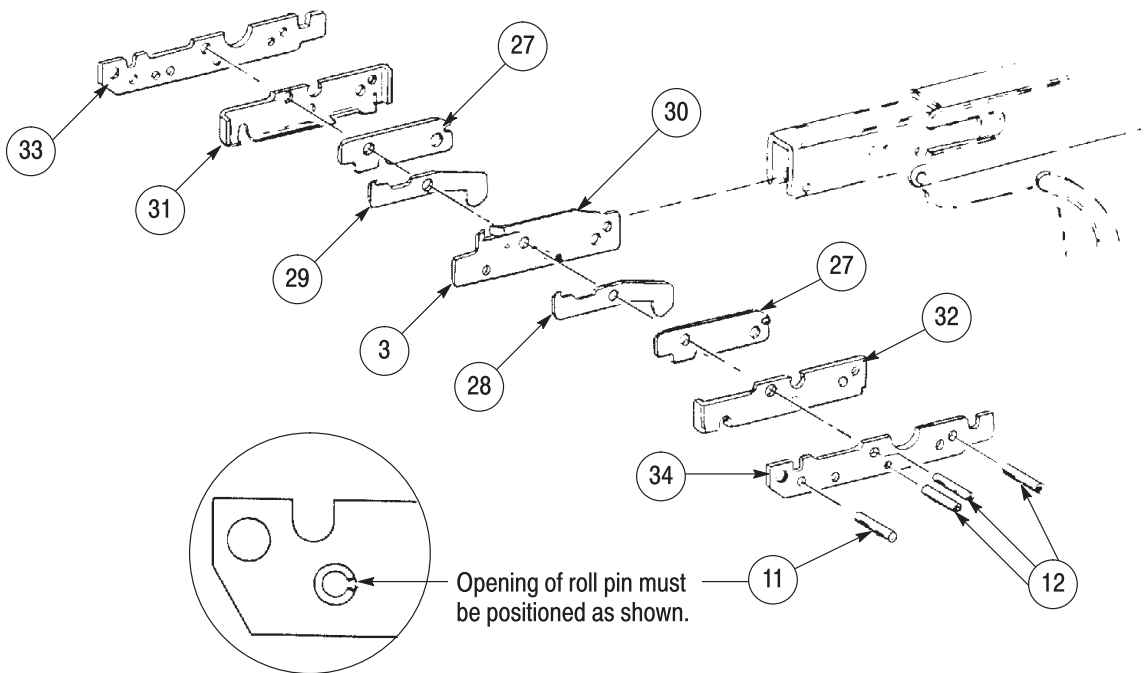
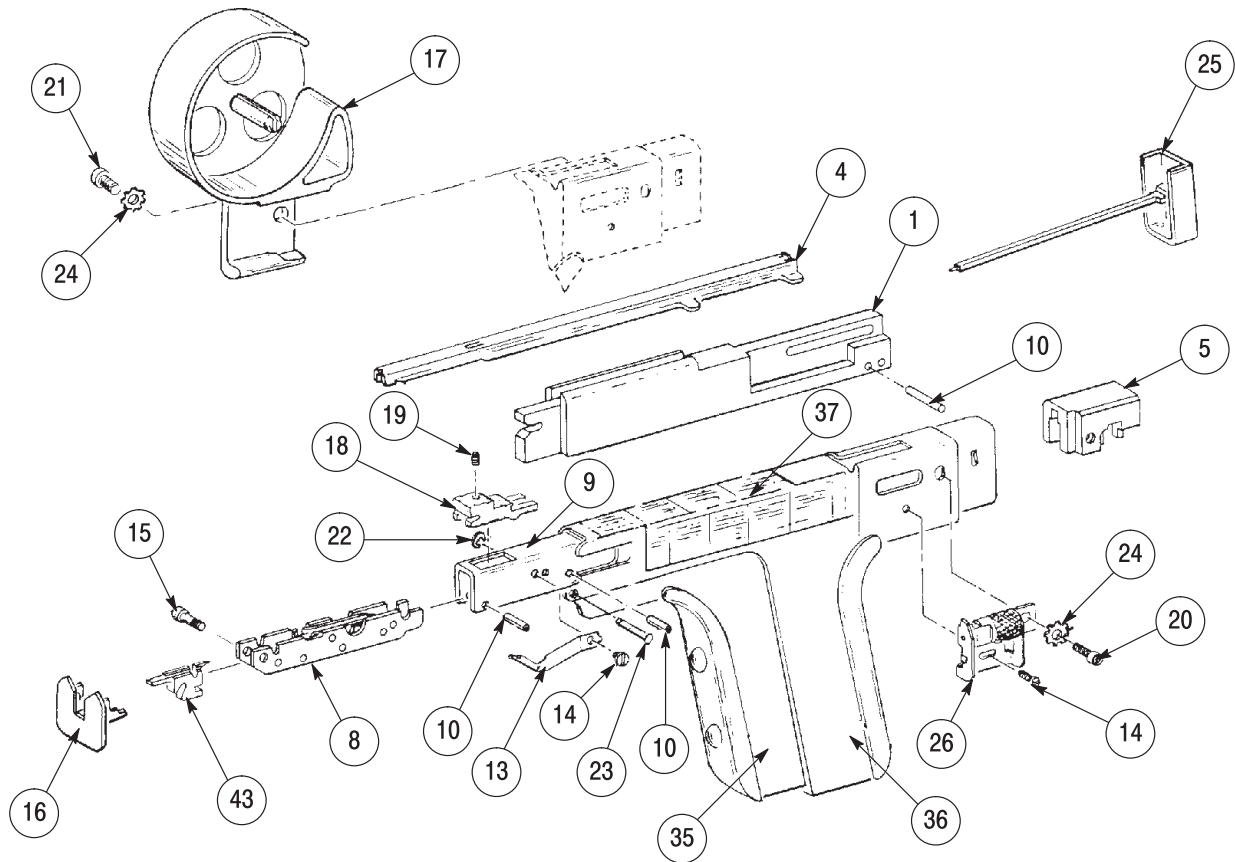

Figure 17 (Continued)

Detail B — Tool 654182-1

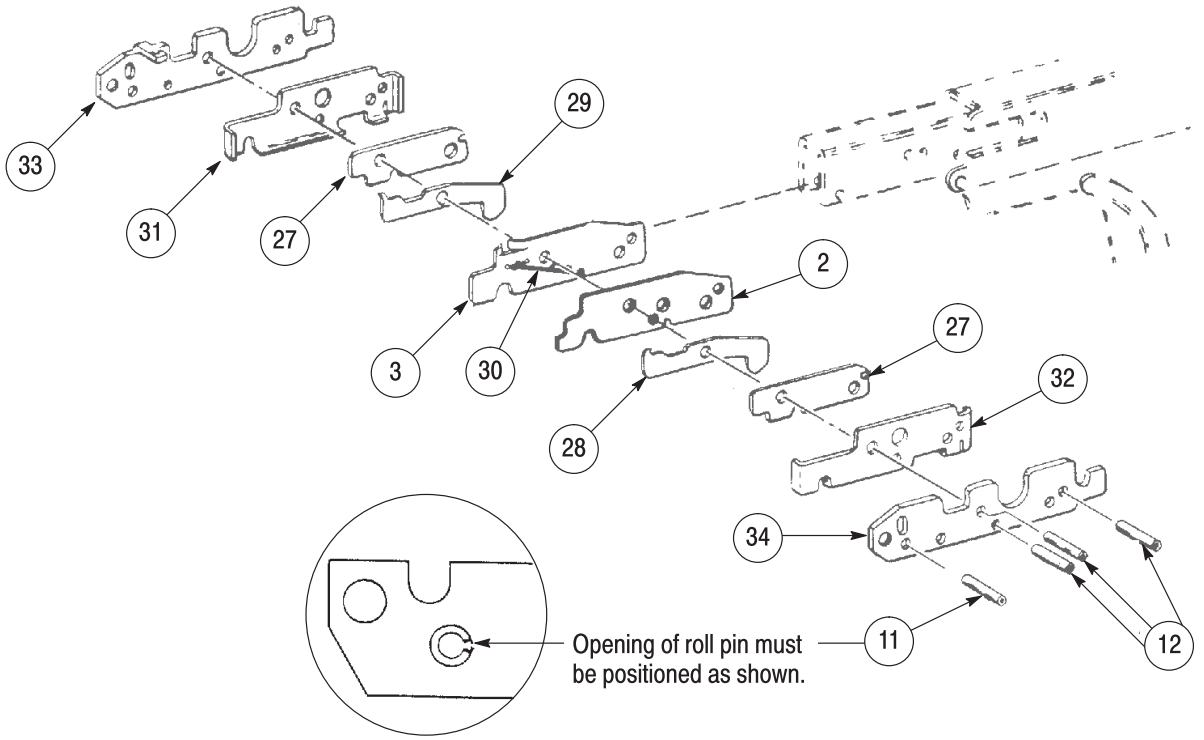
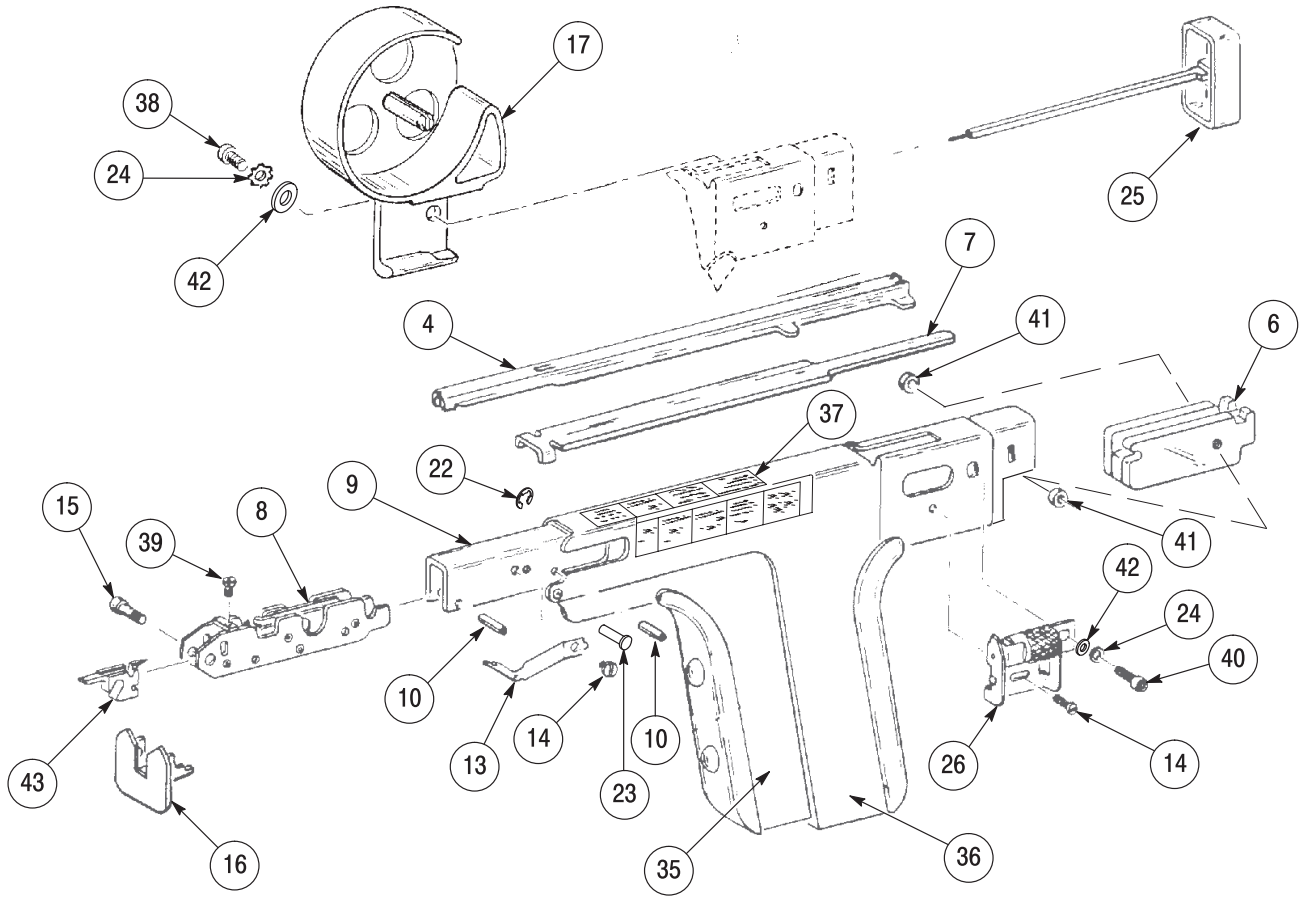

Figure 17 (End)

7.1. Mandrel Replacement

If a mandrel becomes broken or worn, it will be necessary to replace the mandrel to insure proper clip application. Refer to Figure 3 to select the appropriate mandrel.

7.2. Push Rod Replacement

If clips do not feed from the tool, the push rod may be broken or bent. Refer to 17, Item 2 for the push rod assembly part number. The push rod can be replaced without completely dismantling the tool. However, the clips must be removed from the tool as described in Paragraph 3.3.B, Unloading.

Remove the push rod as follows:

- 1 Remove the ram rod loader.
- 2 Remove the reel bracket screws (Figure 17, Item 19) and the reel bracket (Figure 17, Item 18) from the the back of the tool.
- 3 Extract the push rod, push rod plate, and drive block from the back of the tool.

Replace the push rod as follows:

- 1 Squeeze and hold the trigger until it bottoms against the handle. *Do not release the trigger.* See Figure 19, Detail A.
- 2 Insert the push rod plate, wide end first, into the back of the tool. Be sure that the hooks on the push rod plate engage in the left and right side plates. See Figure 19, Detail A.
- 3 Slide the push rod along the top of the push rod plate until the flange on push rod is even with the back of the tool. See Figure 19, Detail B.
- 4 Install the drive block so that the flanges on the push rod engage the notches on on the drive block.

NOTE

The push rod plate must be positioned between the the drive block and the push rod. See Figures 17, Detail B and 17, Detail C.

- 5 Insert the assembled push rod, drive block, and push rod plate in the back of the tool so that the front end of the push rod enters the push rod groove. See Figure 19, Detail D.
- 6 Reassemble the reel bracket and screws.
- 7 Re-install the ram rod loader.

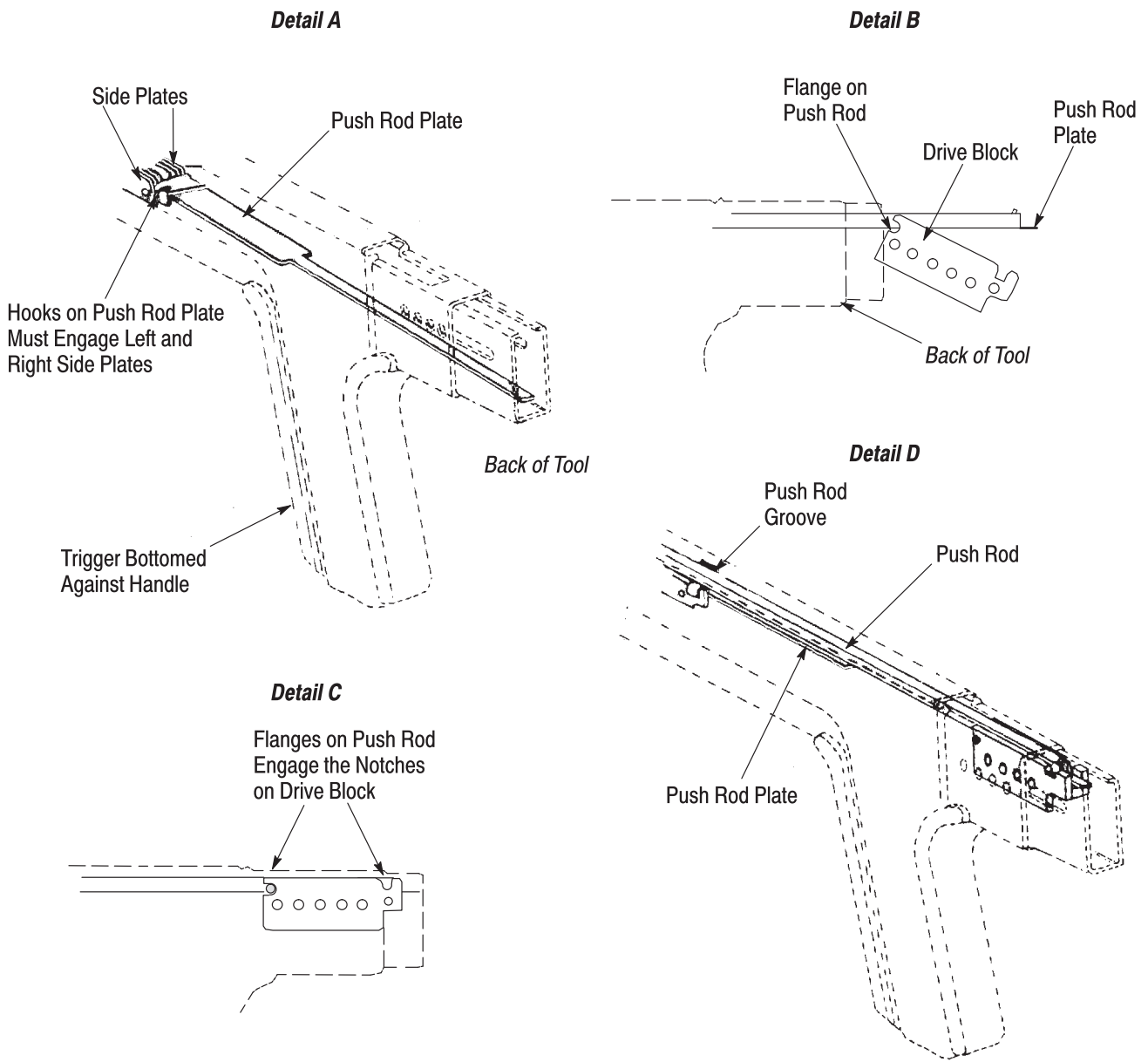

Figure 19

8. REVISION SUMMARY

Revisions to this customer manual include:

- Updated document to corporate requirements
- Removed Label 4-519637-7 (Item 37) from Figure 17, Detail B and added Label 2-305786-0