

DATA SHEET

RM8/I

RM, RM/I, RM/ILP cores and accessories

Supersedes data of September 2004

2008 Sep 01



FERROXCUBE
A YAGEO COMPANY

CORE SETS

Effective core parameters

SYMBOL	PARAMETER	VALUE	UNIT
$\Sigma(l/A)$	core factor (C1)	0.604	mm ⁻¹
V_e	effective volume	2440	mm ³
l_e	effective length	38.4	mm
A_e	effective area	63.0	mm ²
A_{min}	minimum area	55.4	mm ²
m	mass of set	≈ 13	g

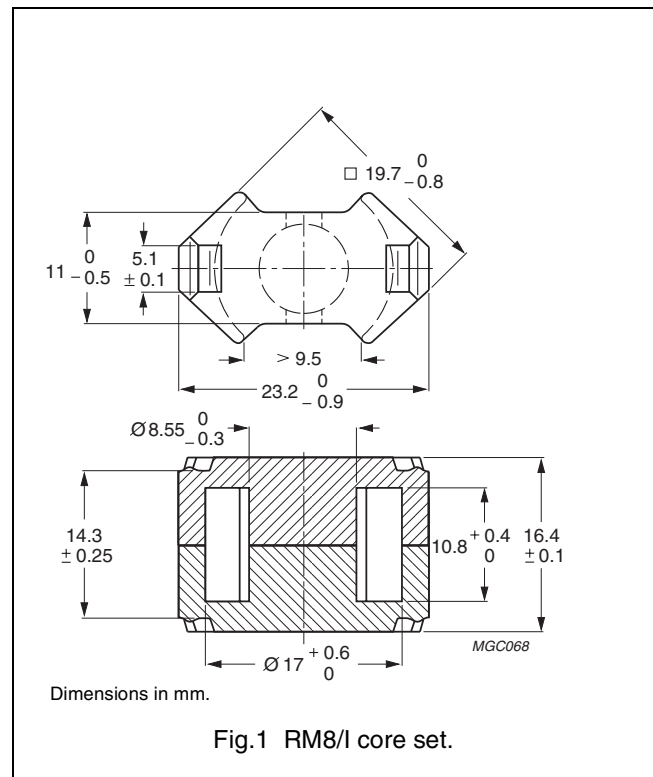

Core sets for filter applications

Clamping force for A_L measurements, 30 ± 10 N.

GRADE	A_L (nH)	μ_e	AIR GAP (μ m)	TYPE NUMBER
3B46 <small>des</small>	$5200 \pm 25 \%$	≈ 2500	≈ 0	RM8/I-3B46
3D3	$250 \pm 3\%$	≈ 121	≈ 360	RM8/I-3D3-A250
	$315 \pm 5\%$	≈ 153	≈ 270	RM8/I-3D3-A315
	$400 \pm 5\%$	≈ 194	≈ 200	RM8/I-3D3-A400
	$1400 \pm 25\%$	≈ 675	≈ 0	RM8/I-3D3
3H3	$400 \pm 3\%$	≈ 194	≈ 200	RM8/I-3H3-A400
	$630 \pm 5\%$	≈ 306	≈ 115	RM8/I-3H3-A630
	$1000 \pm 10\%$	≈ 485	≈ 65	RM8/I-3H3-A1000
	$3250 \pm 25\%$	≈ 1560	≈ 0	RM8/I-3H3

RM, RM/I, RM/ILP cores and accessories

RM8/I

Core sets for general purpose transformers and power applicationsClamping force for A_L measurements, 30 ± 10 N.

GRADE	A_L (nH)	μ_e	TOTAL AIR GAP (μm)	TYPE NUMBER
3C81	100 $\pm 3\%$	≈ 49	≈ 1100	RM8/I-3C81-E100
	160 $\pm 3\%$	≈ 78	≈ 610	RM8/I-3C81-A160
	250 $\pm 3\%$	≈ 121	≈ 360	RM8/I-3C81-A250
	315 $\pm 3\%$	≈ 153	≈ 270	RM8/I-3C81-A315
	400 $\pm 3\%$	≈ 194	≈ 200	RM8/I-3C81-A400
	4100 $\pm 25\%$	≈ 1990	≈ 0	RM8/I-3C81
3C90	100 $\pm 3\%$	≈ 49	≈ 1100	RM8/I-3C90-A100
	160 $\pm 3\%$	≈ 78	≈ 610	RM8/I-3C90-A160
	250 $\pm 3\%$	≈ 121	≈ 360	RM8/I-3C90-A250
	315 $\pm 3\%$	≈ 153	≈ 270	RM8/I-3C90-A315
	400 $\pm 3\%$	≈ 194	≈ 200	RM8/I-3C90-A400
	3300 $\pm 25\%$	≈ 1600	≈ 0	RM8/I-3C90
3C91 des	4100 $\pm 25\%$	≈ 1990	≈ 0	RM8/I-3C91
3C94	100 $\pm 3\%$	≈ 49	≈ 1100	RM8/I-3C94-A100
	160 $\pm 3\%$	≈ 78	≈ 610	RM8/I-3C94-A160
	250 $\pm 3\%$	≈ 121	≈ 360	RM8/I-3C94-A250
	315 $\pm 3\%$	≈ 153	≈ 270	RM8/I-3C94-A315
	400 $\pm 3\%$	≈ 194	≈ 200	RM8/I-3C94-A400
	3300 $\pm 25\%$	≈ 1600	≈ 0	RM8/I-3C94
3C95 des	4100 $\pm 25\%$	≈ 1990	≈ 0	RM8/I-3C95
3C96 des	3000 $\pm 25\%$	≈ 1440	≈ 0	RM8/I-3C96
3F3	100 $\pm 3\%$	≈ 49	≈ 1100	RM8/I-3F3-A100
	160 $\pm 3\%$	≈ 78	≈ 610	RM8/I-3F3-A160
	250 $\pm 3\%$	≈ 121	≈ 360	RM8/I-3F3-A250
	315 $\pm 3\%$	≈ 153	≈ 270	RM8/I-3F3-A315
	400 $\pm 3\%$	≈ 194	≈ 200	RM8/I-3F3-A400
	3000 $\pm 25\%$	≈ 1440	≈ 0	RM8/I-3F3
3F35 prot	2400 $\pm 25\%$	≈ 1150	≈ 0	RM8/I-3F35
3F4 des	100 $\pm 3\%$	≈ 49	≈ 1100	RM8/I-3F4-A100
	160 $\pm 3\%$	≈ 78	≈ 610	RM8/I-3F4-A160
	250 $\pm 3\%$	≈ 121	≈ 360	RM8/I-3F4-A250
	315 $\pm 3\%$	≈ 153	≈ 270	RM8/I-3F4-A315
	400 $\pm 3\%$	≈ 194	≈ 200	RM8/I-3F4-A400
	1700 $\pm 25\%$	≈ 820	≈ 0	RM8/I-3F4
3F45 prot	1700 $\pm 25\%$	≈ 820	≈ 0	RM8/I-3F45

Core sets of high permeability gradesClamping force for A_L measurements, 30 ± 10 N.

GRADE	A_L (nH)	μ_e	TYPE NUMBER
3E27	$8000 \pm 25\%$	≈ 3880	RM8/I-3E27
3E5	$12500 +40/-30\%$	≈ 6060	RM8/I-3E5
3E6	$15500 +40/-30\%$	≈ 7520	RM8/I-3E6

Properties of core sets under power conditions

GRADE	B (mT) at	CORE LOSS (W) at				
	H = 250 A/m; f = 25 kHz; T = 100 °C	f = 25 kHz; $\hat{B} = 200$ mT; T = 100 °C	f = 100 kHz; $\hat{B} = 100$ mT; T = 100 °C	f = 100 kHz; $\hat{B} = 200$ mT; T = 25 °C	f = 100 kHz; $\hat{B} = 200$ mT; T = 100 °C	f = 400 kHz; $\hat{B} = 50$ mT; T = 100 °C
3C81	≥ 315	≤ 0.56	–	–	–	–
3C90	≥ 320	≤ 0.30	≤ 0.31	–	–	–
3C91	≥ 315	–	$\leq 0.17^{(1)}$	–	$\leq 1.0^{(1)}$	–
3C94	≥ 320	–	≤ 0.23	–	≤ 1.2	–
3C95	≥ 320	–	–	≤ 1.44	≤ 1.37	–
3C96	≥ 340	–	≤ 0.17	–	≤ 1.0	≤ 0.43
3F3	≥ 315	–	≤ 0.27	–	–	≤ 0.47
3F35	≥ 315	–	–	–	–	≤ 0.25
3F4	≥ 250	–	–	–	–	–

Properties of core sets under power conditions (continued)

GRADE	B (mT) at	CORE LOSS (W) at				
	H = 250 A/m; f = 25 kHz; T = 100 °C	f = 500 kHz; $\hat{B} = 50$ mT; T = 100 °C	f = 500 kHz; $\hat{B} = 100$ mT; T = 100 °C	f = 1 MHz; $\hat{B} = 30$ mT; T = 100 °C	f = 1 MHz; $\hat{B} = 50$ mT; T = 100 °C	f = 3 MHz; $\hat{B} = 10$ mT; T = 100 °C
3C96	≥ 340	≤ 0.9	–	–	–	–
3F3	≥ 315	–	–	–	–	–
3F35	≥ 315	≤ 0.37	≤ 2.6	–	–	–
3F4	≥ 250	–	–	≤ 0.74	–	≤ 1.2
3F45	≥ 250	–	–	≤ 0.56	≤ 2.1	≤ 1.0

Note

1. Measured at 60 °C.

COIL FORMER

General data

PARAMETER	SPECIFICATION
Coil former material	polybutyleneterephthalate (PBT), glass-reinforced, flame retardant in accordance with "UL 94V-0"; UL file number E45329(R)
Pin material	copper-tin alloy (CuSn), tin (Sn) plated
Maximum operating temperature	155 °C, "IEC 60085", class F
Resistance to soldering heat	"IEC 60068-2-20", Part 2, Test Tb, method 1B, 350 °C, 3.5 s
Solderability	"IEC 60068-2-20", Part 2, Test Ta, method 1

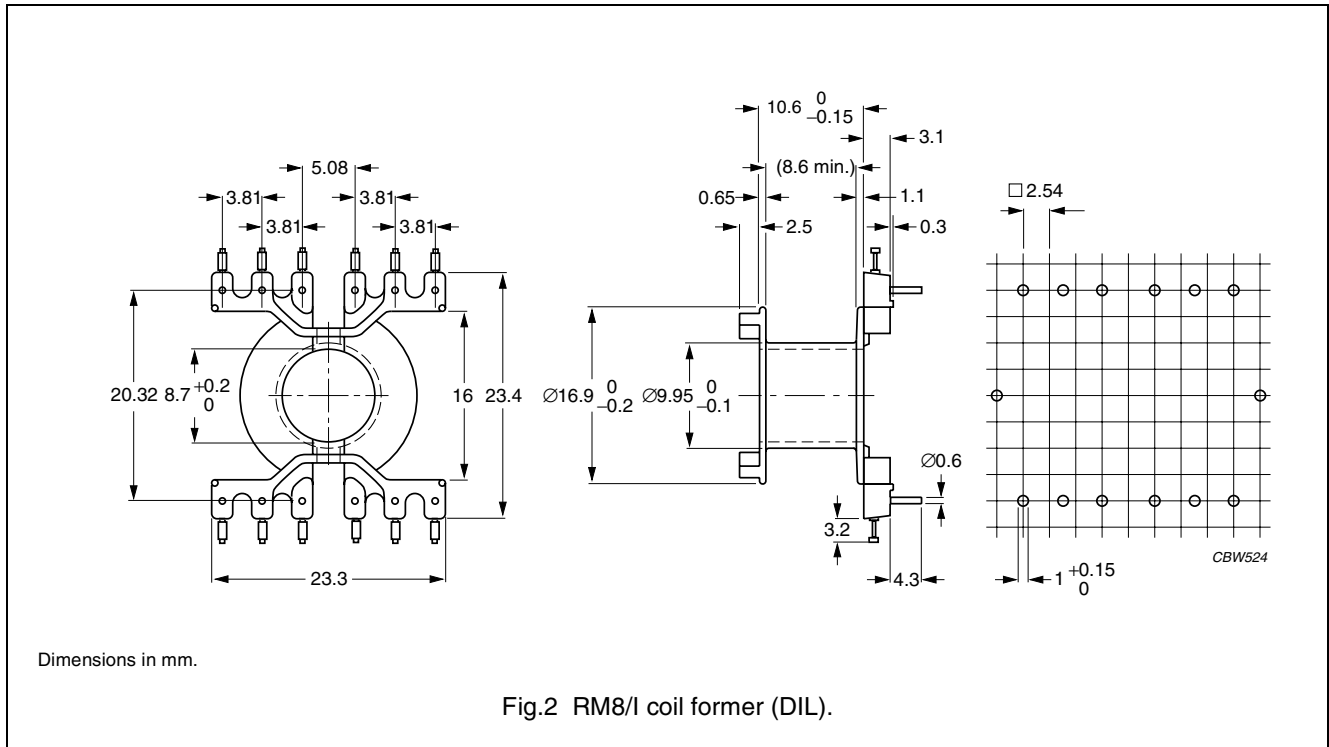

Winding data and area product for RM8/I coil former (DIL)

NUMBER OF SECTIONS	AVERAGE LENGTH OF TURN (mm)	WINDING AREA (mm ²)	WINDING WIDTH (mm)	AREA PRODUCT Ae x Aw (mm ⁴)	TYPE NUMBER
1	42	30.9	8.6	1950	CPV-RM8/I-1S-12PD

RM, RM/I, RM/ILP cores and accessories

RM8/I

Additional coilformers are those of "RM8", but "area product" is different.

Winding data and area product (for RM8/I) for RM8 coil former

NUMBER OF SECTIONS	NUMBER OF PINS	PIN POSITIONS USED	AVERAGE LENGTH OF TURN (mm)	WINDING AREA (mm ²)	WINDING WIDTH (mm)	AREA PRODUCT $A_e \times A_w$ (mm ⁴)	TYPE NUMBER
1	8	1, 2, 5, 6, 7, 8, 11, 12	42	30	9.1	1890	CSV-RM8-1S-8P-G ⁽¹⁾
1	12	all	42	30	9.1	1890	CSV-RM8-1S-12P-G ⁽¹⁾
2	8	1, 2, 5, 6, 7, 8, 11, 12	42	2 × 13.5	2 × 4.3	2 × 850	CSV-RM8-2S-8P
2	12	all	42	2 × 13.5	2 × 4.3	2 × 850	CSV-RM8-2S-12P-G
1	4	3, 4, 9, 10	42	30	9.1	1890	CSV-RM8-1S-4P
1	5	1, 2, 5, 8, 11	42	30	9.1	1890	CSV-RM8-1S-5P
2	5	1, 2, 5, 8, 11	42	2 × 13.5	2 × 4.3	2 × 850	CSV-RM8-2S-5P

Note 1. Also available with post-inserted pins.

MOUNTING PARTS

General data

ITEM	SPECIFICATION
Clamping force	≈15 N
Clip material	stainless steel
Clip plating	tin (Sn)
Solderability	"IEC 60068-2-20", Part 2, Test Ta, method 1
Type number	CLI/P-RM8/I

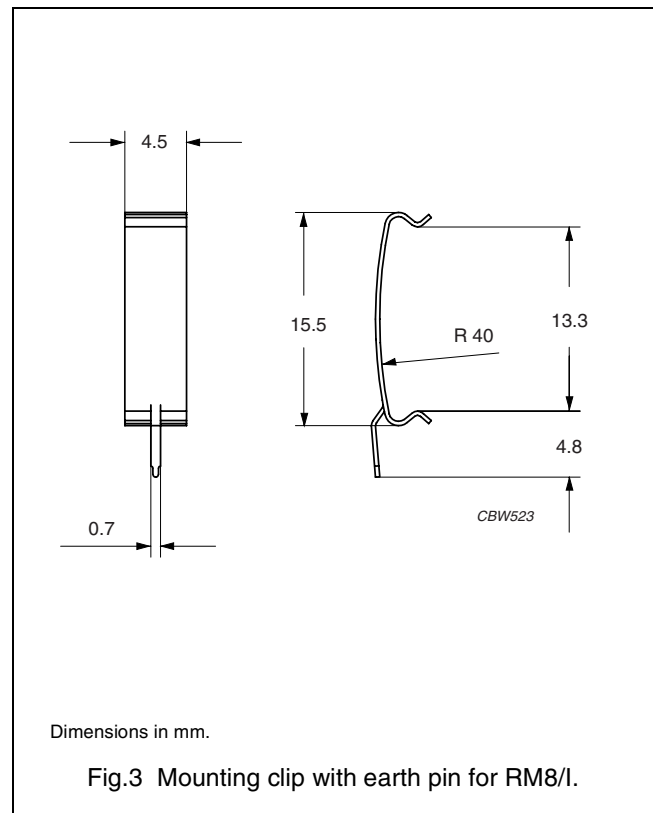

General data

ITEM	SPECIFICATION
Clamping force	≈15 N
Clip material	stainless steel
Type number	CLI-RM8/I

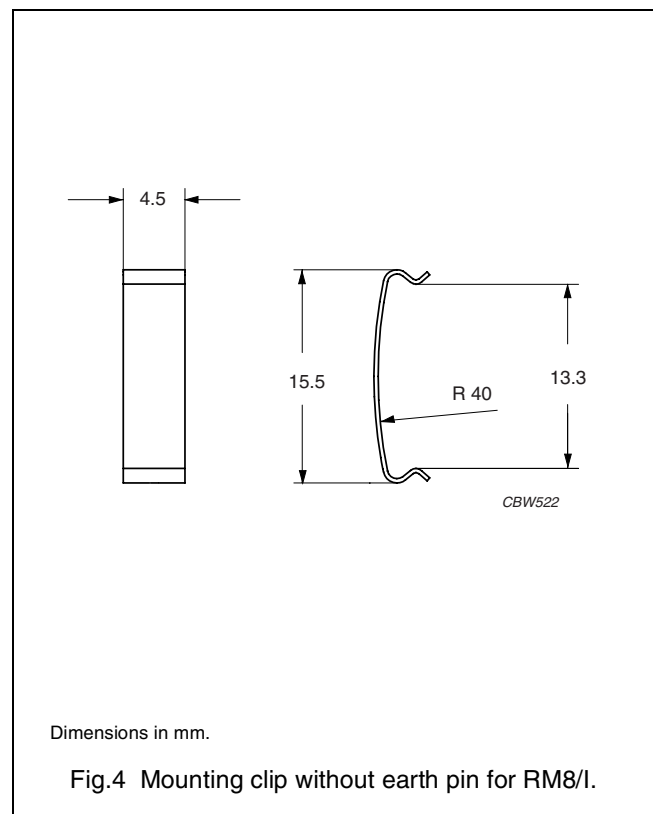



DATA SHEET STATUS DEFINITIONS

DATA SHEET STATUS	PRODUCT STATUS	DEFINITIONS
Preliminary specification	Development	This data sheet contains preliminary data. Ferroxcube reserves the right to make changes at any time without notice in order to improve design and supply the best possible product.
Product specification	Production	This data sheet contains final specifications. Ferroxcube reserves the right to make changes at any time without notice in order to improve design and supply the best possible product.

DISCLAIMER

Life support applications — These products are not designed for use in life support appliances, devices, or systems where malfunction of these products can reasonably be expected to result in personal injury. Ferroxcube customers using or selling these products for use in such applications do so at their own risk and agree to fully indemnify Ferroxcube for any damages resulting from such application.

PRODUCT STATUS DEFINITIONS

STATUS	INDICATION	DEFINITION
Prototype		These are products that have been made as development samples for the purposes of technical evaluation only. The data for these types is provisional and is subject to change.
Design-in		These products are recommended for new designs.
Preferred		These products are recommended for use in current designs and are available via our sales channels.
Support		These products are not recommended for new designs and may not be available through all of our sales channels. Customers are advised to check for availability.