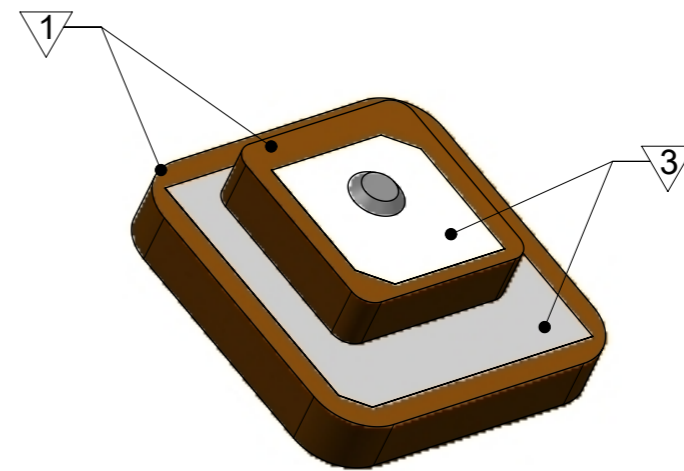
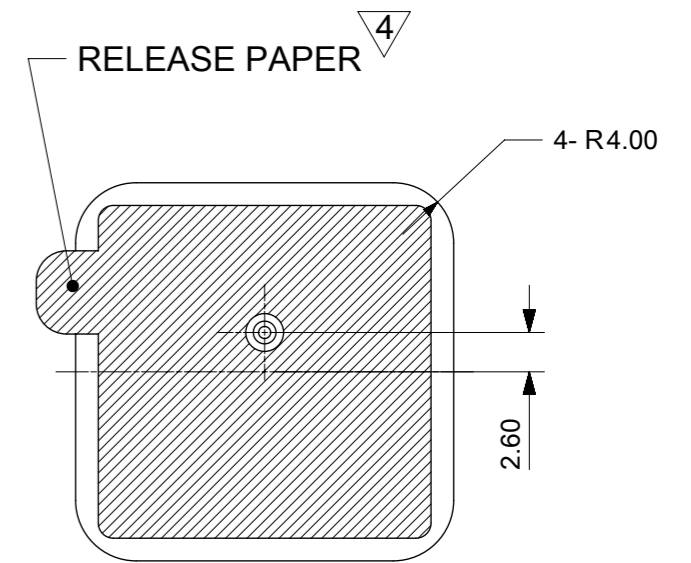
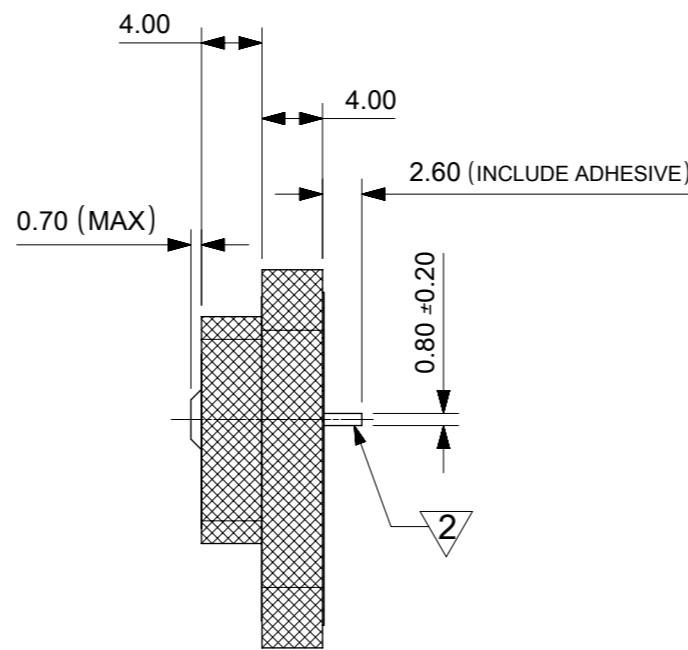
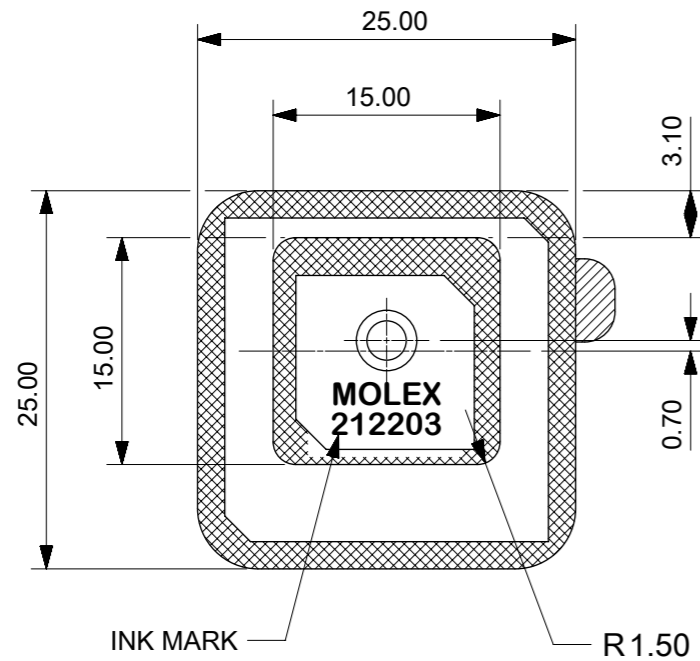

TABLE A		
No.	DESCRIPTION	STRUCTURE AND MATERIAL
1	ANTENNA SUBSTRATE	DIELECTRIC CERAMICS
2	PIN	COPPER AND TINPLATED
3	PATCH	Ag PLATED
4	ADHESIVE TYPE	NITTO 5000NS

REV.	DATE	CHANGE DESCRIPTION
A	2019/03/18	NEW RELEASE
B	2019/05/21	ADD ADHESIVE THICKNESS



3D VIEW



NOTES:

1. MATERIAL: CERAMIC.
2. GENERAL COSMETIC APPEARANCE AS DEFINED BY MOLEX COSMETIC SPECIFICATION.
3. STRUCTURE AND MATERIAL REFERENCE TABLE A
4. NITTO 5000NS THICKNESS:0.16mm.

SYMBOLS		THIS DRAWING CONTAINS INFORMATION THAT IS PROPRIETARY TO MOLEX ELECTRONIC TECHNOLOGIES, LLC AND SHOULD NOT BE USED WITHOUT WRITTEN PERMISSION	
▽ = 0	mm	SCALE	2:1
▽ = 0	GENERAL TOLERANCES (UNLESS SPECIFIED)		
▽ = 0	ANGULAR TOL ± °		
▽ = 0	4 PLACES ±	CURRENT REV DESC:	
▽ = 0	3 PLACES ±	EC NO: 616280	
▽ = 0	2 PLACES ± 0.5	DRWN: KCHENG06 2019/05/21	
▽ = 0	1 PLACE ±	CHK'D: XJSONG 2019/05/23	
▽ = 0	0 PLACES ±	APPR: XJSONG 2019/05/23	
□ = 0	INITIAL REVISION:		
■ = 0	DRWN: KCHENG06 2019/03/18		
▽ = 0	APPR: XJSONG 2019/04/22		
DRAFT WHERE APPLICABLE MUST REMAIN WITHIN DIMENSIONS		THIRD ANGLE PROJECTION	DRAWING
		A3-SIZE	SERIES
		212203	MATERIAL NUMBER
		2122030001	CUSTOMER
		GENERAL MARKET	SHEET NUMBER
		1 OF 1	