

REVISIONS			
REV	DESCRIPTION	DATE	APPROVED

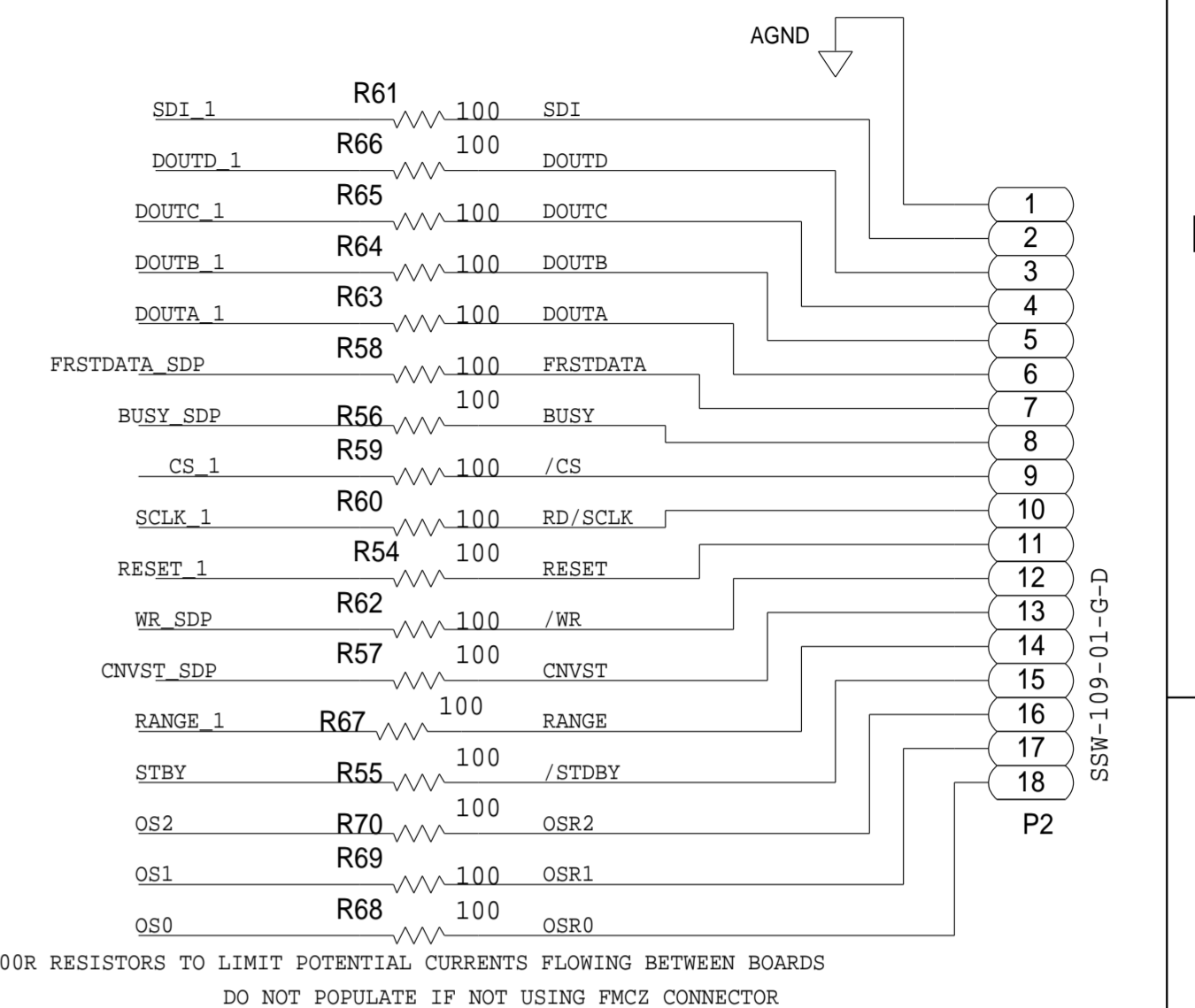

100R RESISTORS TO LIMIT POTENTIAL CURRENTS FLOWING BETWEEN BOARDS
DO NOT POPULATE IF NOT USING FM2Z CONNECTOR

JP1, JP4, JP5, JP6 TO BE USED ONLY IF USING THE BOARD IN STANDALONE
LEAVE THEM AT DEFAULT POSITION IF USING AD7606B EVALUATION SOFTWARE

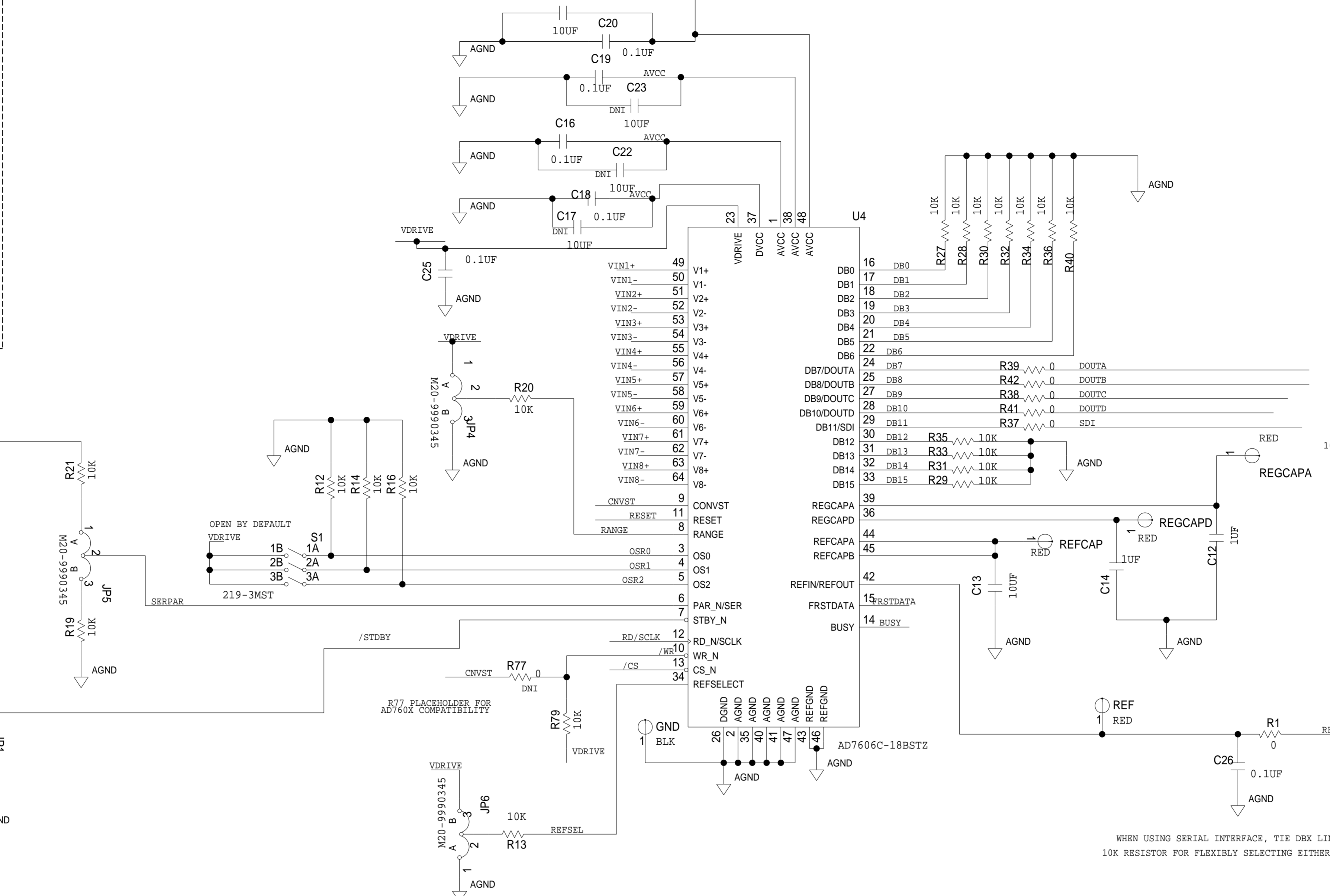
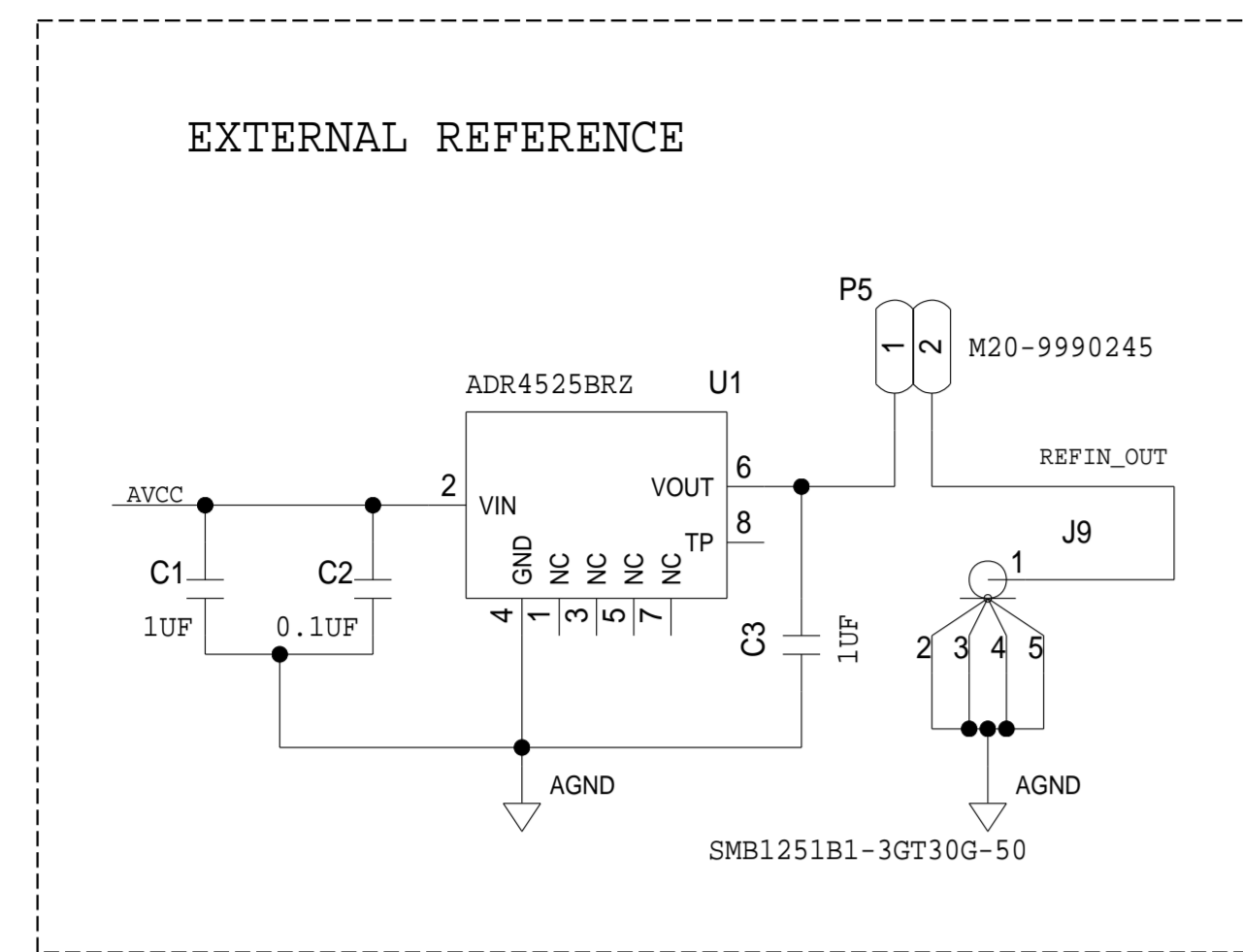

WHEN USING SERIAL INTERFACE, TIE DBX LINES TO AGND
10K RESISTOR FOR FLEXIBLY SELECTING EITHER SERIAL OR PARALLEL INTERFACE ON EVAL BOARD

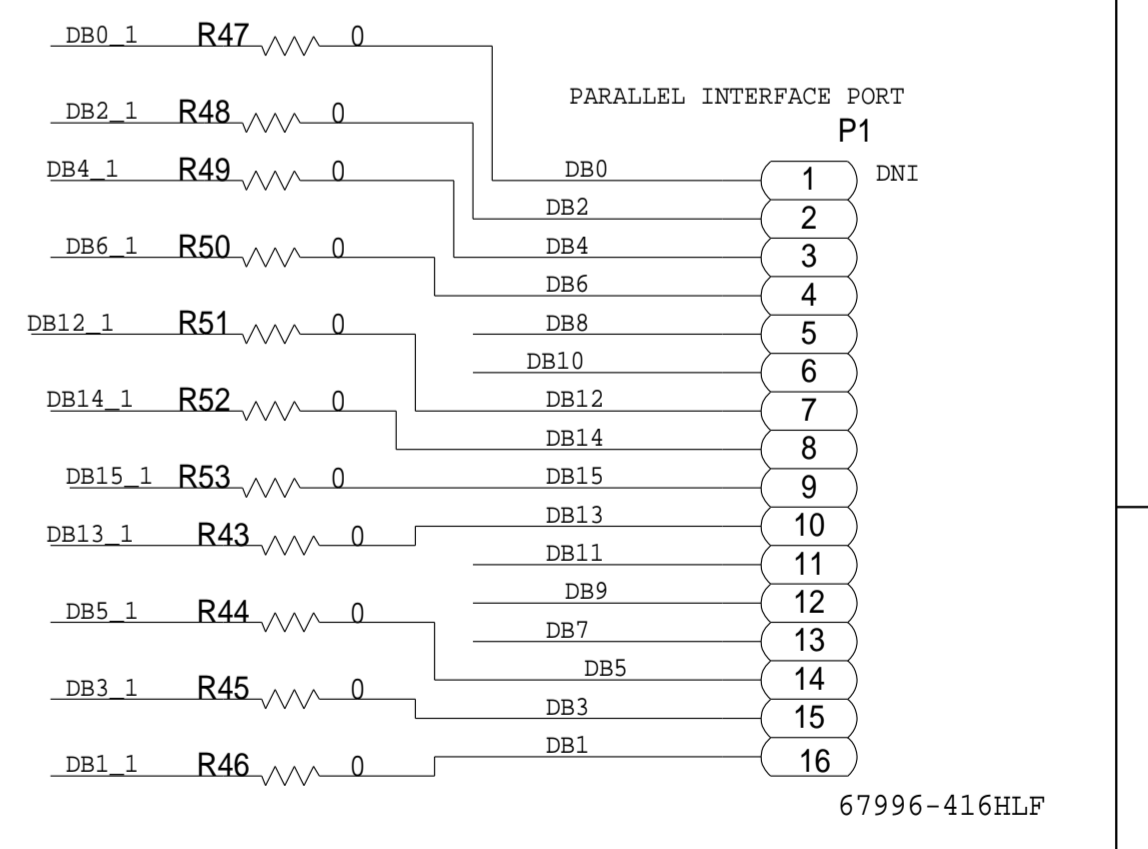
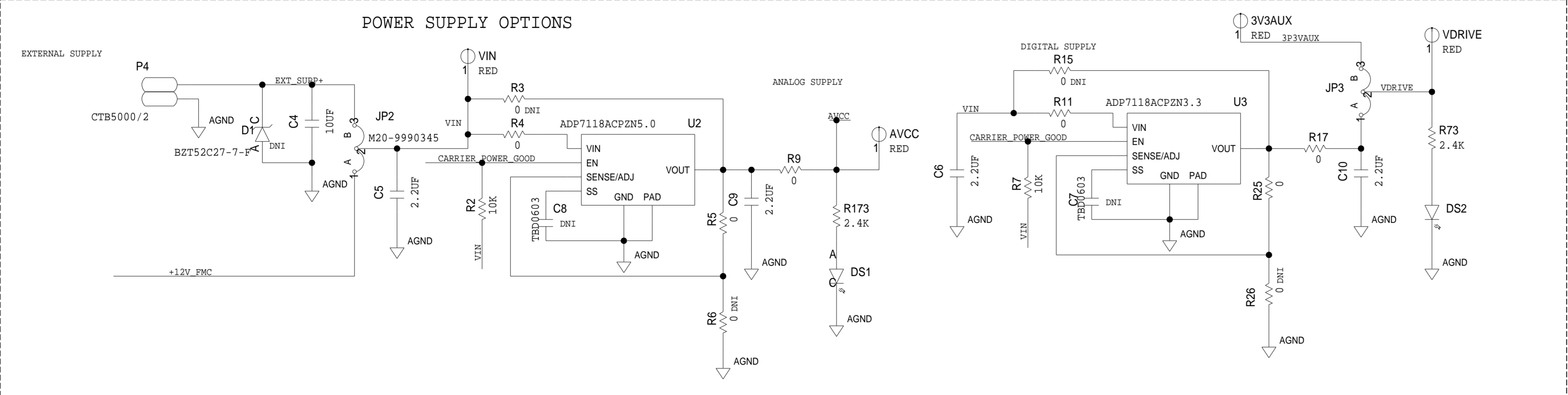

	SCHEMATIC		
	HW TYPE : Customer Evaluation Product(s) : AD7606C-18 : n/a		
	DESIGN VIEW <DESIGN_VIEW>	DRAWING NO. 02_057655	REV B
	PTD ENGINEER <PTD_ENGINEER>	SIZE D	SCALE 1:1
		SHEET 2 OF 4	

REVISIONS			
REV	DESCRIPTION	DATE	APPROVED

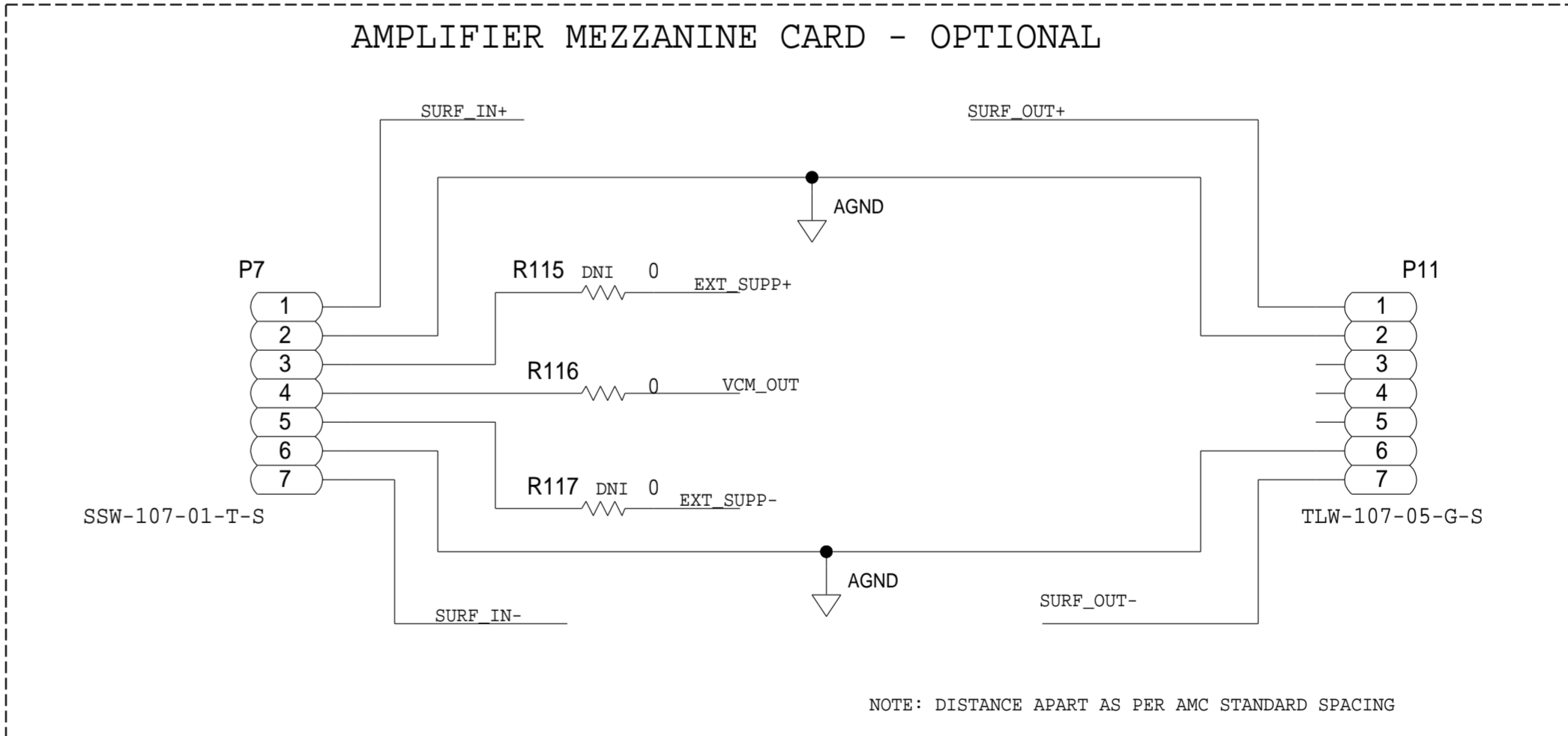
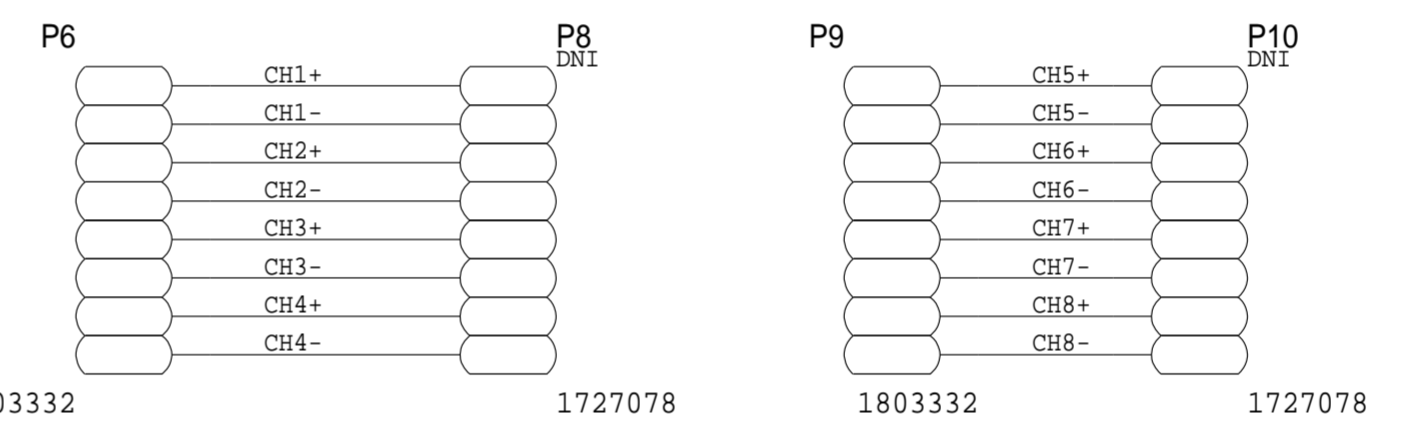
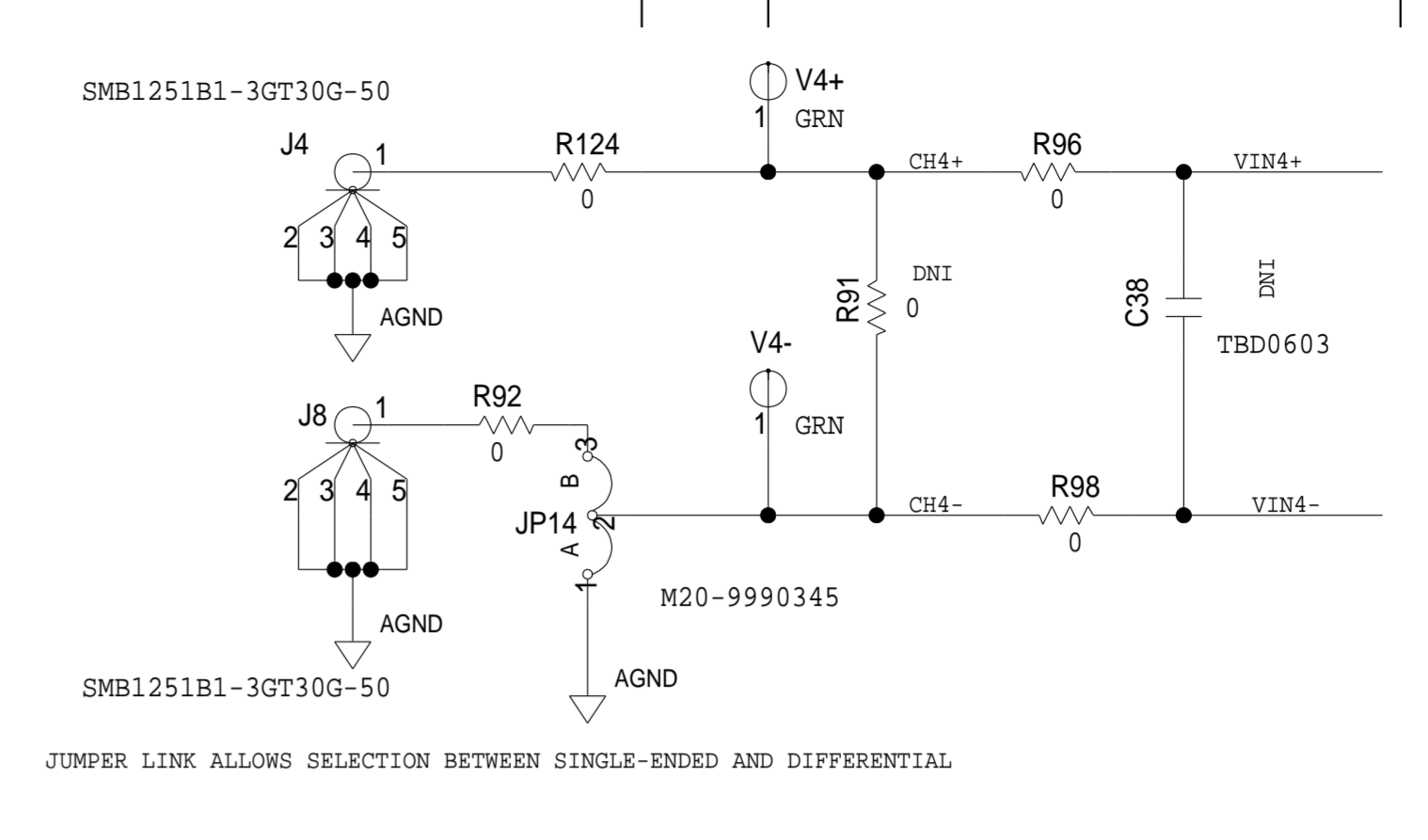
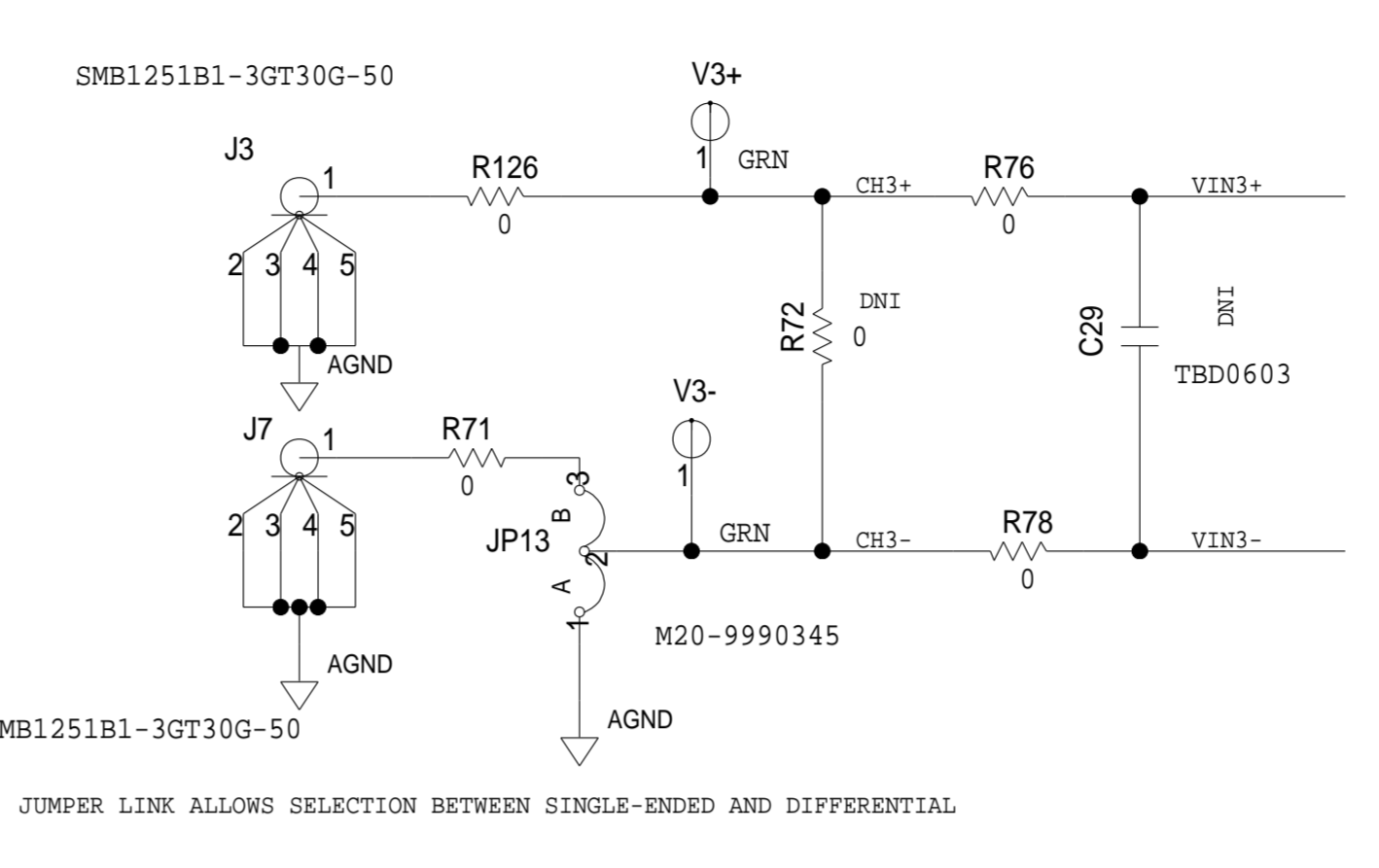
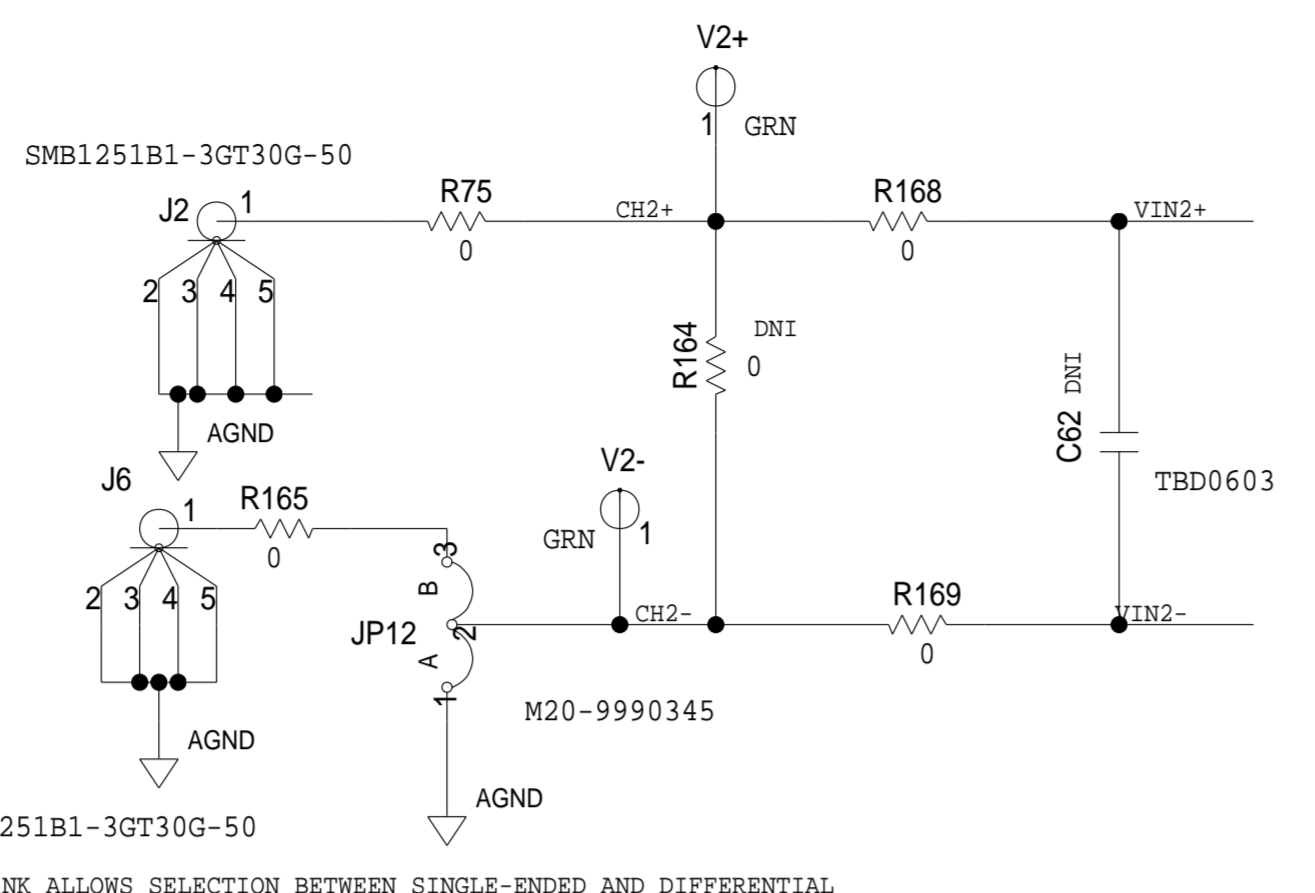
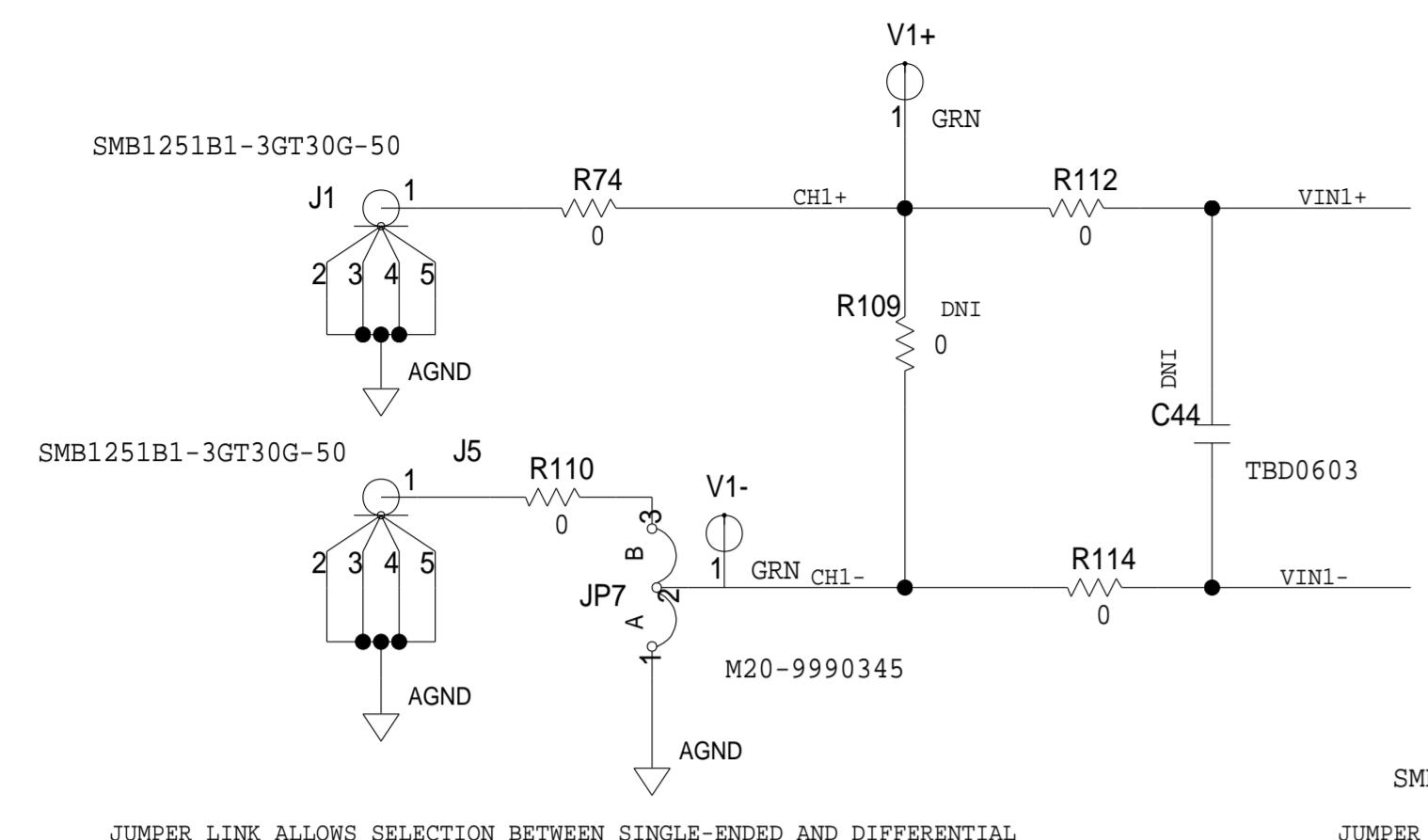

JUMPER LINK ALLOWS SELECTION BETWEEN SINGLE-ENDED AND DIFFERENTIAL

JUMPER LINK ALLOWS SELECTION BETWEEN SINGLE-ENDED AND DIFFERENTIAL

JUMPER LINK ALLOWS SELECTION BETWEEN SINGLE-ENDED AND DIFFERENTIAL

JUMPER LINK ALLOWS SELECTION BETWEEN SINGLE-ENDED AND DIFFERENTIAL

JUMPER LINK ALLOWS SELECTION BETWEEN SINGLE-ENDED AND DIFFERENTIAL

	SCHEMATIC			
	HW TYPE : Customer Evaluation			
	Product(s) : AD7606C-18			
	: n/a			
DESIGN VIEW	DRAWING NO.		REV	
<DESIGN_VIEW>	02_057655		B	
PTD ENGINEER	SIZE	SCALE	SHEET 3 OF 4	
<PTD_ENGINEER>	D	1:1		

REVISIONS			
REV	DESCRIPTION	DATE	APPROVED

FPGA FMC CONNECTIONS

LIST OF FMC-LPC CONNECTOR PINS THAT ARE NOT CONNECTED ON THE SDP-H1:

- C2 (DP0_C2M_P)
- C3 (DP0_C2M_N)
- C6 (DP0_M2C_P)
- C7 (DP0_M2C_N)
- D4 (GBTCLK0_M2C_P)
- D5 (GBTCLK0_M2C_N)
- H1 (VREF_A_M2C)

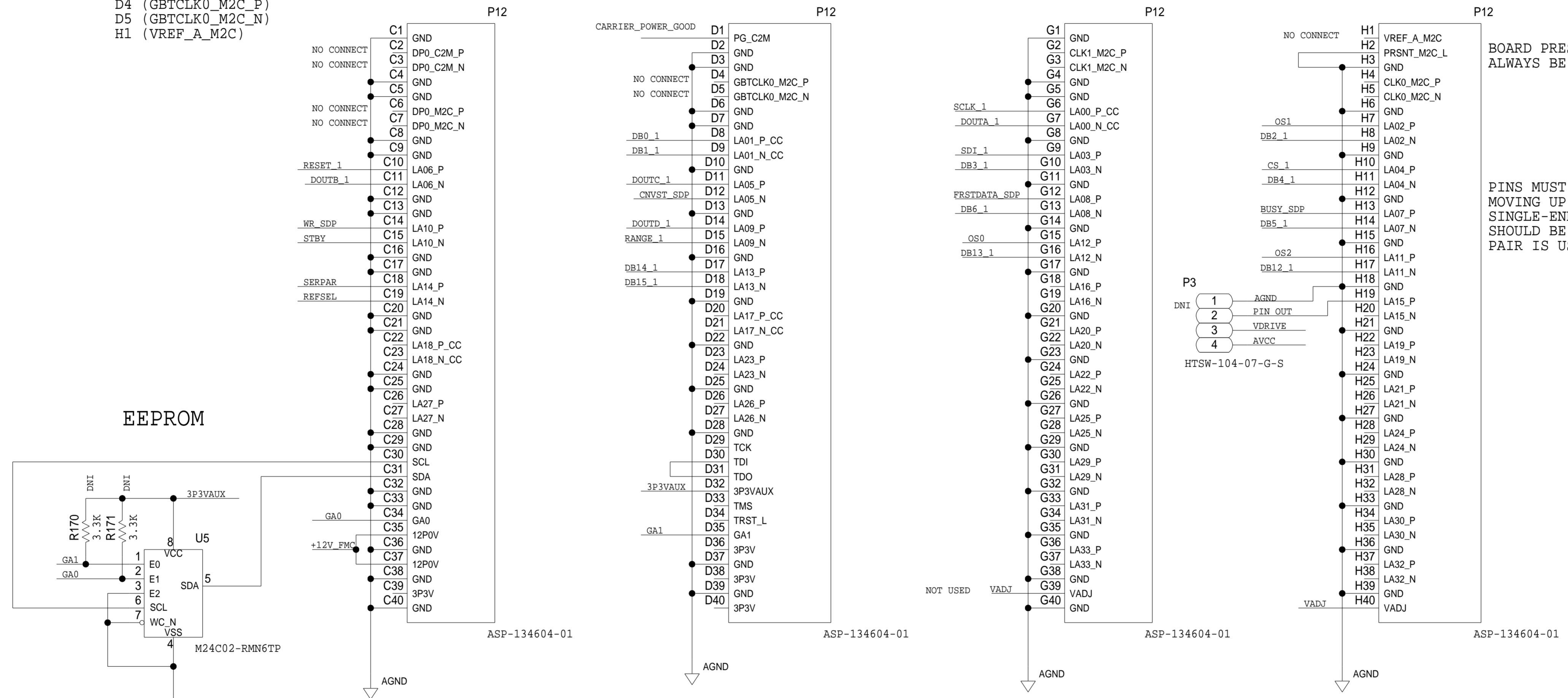

BOARD PRESENT PIN (H2) MUST ALWAYS BE TIED TO GROUND

PINS MUST BE ASSIGNED STARTING WITH LA00 AND MOVING UP THE LA BUS UNTIL IT IS FULL. WHEN SINGLE-ENDED SIGNALING IS USED, THE _P LINE SHOULD BE USED BEFORE THE _N LINE OF THE SAME PAIR IS USED.

EEPROM REQUIRED IN VITA57.1 STANDARD. I2C LINE PULL-UP RESISTORS ON FPGA BOARD. I2C ADDRESS SET BY CONTROLLER BOARD.

IF EVAL BOARD DOES NOT USE JTAG TDI AND TDO THEN THEY MUST BE SHORTED TOGETHER (AS SHOWN) SO AS NOT TO BREAK JTAG CHAIN

POWER SUPPLIES:
 12P0V. 1A MAX CURRENT LIMIT
 3P3V. 3A MAX CURRENT LIMIT
 VADJ. 2A MAX CURRENT LIMIT. 1.2V TO 3.3V.

	SCHEMATIC		
	HW TYPE : Customer Evaluation Product(s) : AD7606C-18 : n/a		
DESIGN VIEW <DESIGN_VIEW>	DRAWING NO. 02_057655	REV B	
PTD ENGINEER <PTD_ENGINEER>	SIZE D	SCALE 1:1	SHEET 4 OF 4