

THIS DRAWING IS UNPUBLISHED. RELEASED FOR PUBLICATION
 © COPYRIGHT - By Tyco Electronics Japan G.K. ALL RIGHTS RESERVED.

REVISIONS					
P	LTR	DESCRIPTION	DATE	DWN	APVD
	A9	ECR-19-016260 Remove note Restrict sale	18OCT2019	S.N	J.S

PART NUMBER	QTY	IZUMI P/N	REMARKS
2155363-1	1	REC-Li250M	WITH DIES 圧着ダイス込み (WITH A BATTERY BP-14LN)
2155363-2	1	REC-Li250M-ND	WITHOUT DIES 圧着ダイスなし (WITH A BATTERY BP-14LN)
2155363-3	1	BP-14LN	BATTERY バッテリーパック SPARE PART
2155363-4	1	119878200	BATTERY CHARGER CORD (LITHIUM), (FOR CE SPEC.) 充電器用コード・海外向け OPTION
2155363-5	1	200AT-T240	ATTACHMENT, TE REC-Li250M OPTION
2155363-6	1	Patting part for REC	Common part of REC60 and REC250. This will be sold from one piece. 1個から購入可 OPTION



-6 AS SHOWN



-3 AS SHOWN



-4 AS SHOWN



-5 AS SHOWN

THIS DRAWING IS A CONTROLLED DOCUMENT.

DIMENSIONS: mm	TOLERANCES UNLESS OTHERWISE SPECIFIED:
	0 PLC ± -
	1 PLC ± -
	2 PLC ± -
	3 PLC ± -
	4 PLC ± -
	ANGLES ± -
MATERIAL	FINISH
-	-

DWN	S.NAKA	10SEP2011
CHK	S.NAKA	10SEP2011
APVD	J.KOGA	10SEP2011
PRODUCT SPEC	-	
APPLICATION SPEC	-	
WEIGHT	-	
CUSTOMER DRAWING		

STE TE Connectivity			
NAME TE REC-Li250M BATTERY OPERATED COMPRESSION TOOL			
SIZE	CAGE CODE	DRAWING NO	RESTRICTED TO
A3	00779	C-2155363	-
SCALE	SHEET	REV	
-	1 OF 2	A9	

THIS DRAWING IS UNPUBLISHED. RELEASED FOR PUBLICATION
 © COPYRIGHT - By Tyco Electronics Japan G.K. ALL RIGHTS RESERVED.

REVISIONS					
P	LTR	DESCRIPTION	DATE	DWN	APVD
	-	SEE SHEET 1	-	-	-

SPECIFICATIONS 仕様

Force at die face	公称出力	127kN
Applicable wire range	圧着範囲	14~250mm ²
Applicable terminal 適用端子	Terminal for copper wire and sleeve (NON TE) 銅線用端子及びスリーブ (TE製品は不可)	△1
Size	外形寸法	341(L)x246(H)x73(W)mm
Weight 質量	4.3kg (with battery and 250mm ² dies) 4.3kg (バッテリーパックと250mm ² ダイスを含む)	
Number of crimps per charge for 250mm ² dies. 圧着可能回数 (250mm ² ダイス圧着時)	50 crimps 50 回	

ACCESSORIES 付属品

Battery	バッテリーパック	BP-14LN		
Charger	充電器	CH-25LNW		
Dies	For -1 only	Moving die オス	14, 22, 38~70, 80~150, 200, 250 (mm ²)	△1 △2
圧着ダイス	-1のみに付属	Stationary die メス	14~38, 60~70, 80~100, 150, 200, 250 (mm ²)	△1 △2
Carrying case	キャリングケース	W/B Case	ダブルブロー	

NOTE

△1 JIS C 2805 (銅線用裸圧着端子)、JIS C 2806 (銅線用裸圧着スリーブの直線突合せ用スリーブB および直線重ね合せ用スリーブP) に基づく 14~250mm² の圧着接続用。
 TE 製の端子には適用していません。

14 to 250 mm² for the crimp terminals of JIS C 2805 and JIS C 2806. (JIS: Japanese Industrial Standards)
 It has not applied to the TE terminal.

△2 ダイスと電線の組合せ表 Combination table of dies and wire.

適用電線 コネクタの 呼び Terminal name	ダイス組合せ Combination dies		電線組合せ Combination wire (mm ²)		
	雄ダイス Moving die	雌ダイス Stationary die	JIS C 2805 銅線用裸圧着端子 Non-insulated crimp terminal for copper conductor	JIS C 2806 銅線用圧着スリーブ Non-insulated crimp sleeve for copper conductor 直線突合せ用 (B) Butt splice (B)	
14	14	14-38	14	14 & 14	5.5 & 5.5 8 & 8
22	22		22	22 & 22	8 & 14
38	38-70		38	38 & 38	14 & 14
60		60	60 & 60	22 & 22	
70	80-150	60-70	-	-	38 & 38
80			-	-	22 & 60
100		100	80-100	100	100 & 100
150	150	150	150	150 & 150	60 & 60
200	200	200 △3	200	200 & 200	100 & 100
250	250	250 △3	250 △4	-	-

△3 圧着ヨーク。 Crimping yoke.

△4 JIS規格品ではありません。 Non-JIS.

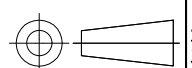
THIS DRAWING IS A CONTROLLED DOCUMENT.		DWN S.NAKA	10SEP2011	 TE Connectivity				
DIMENSIONS: mm		CHK S.NAKA	10SEP2011					
TOLERANCES UNLESS OTHERWISE SPECIFIED:		APVD J.KOGA	10SEP2011	NAME TE REC-Li250M				
		PRODUCT SPEC		BATTERY OPERATED COMPRESSION TOOL				
0 PLC ± - 1 PLC ± - 2 PLC ± - 3 PLC ± - 4 PLC ± - ANGLES ± -		APPLICATION SPEC		SIZE	CAGE CODE	DRAWING NO		
MATERIAL		FINISH		WEIGHT	A3	00779	C-2155363	RESTRICTED TO
CUSTOMER DRAWING				SCALE	-	SHEET	2 OF 2	REV
								A9