

Housing - HC-STA-D15-HLFS-1TTP13-ELC-AL - 1424352

Please be informed that the data shown in this PDF Document is generated from our Online Catalog. Please find the complete data in the user's documentation. Our General Terms of Use for Downloads are valid (<http://phoenixcontact.com/download>)



Sleeve housing D15, for single locking latch, material: Die-cast aluminum, salt water resistant, cable outlets: 1, straight, height: 56 mm, cable gland: none, support sleeve: no, 1x Pg13,5, Standard



Key Commercial Data

Packing unit	1 pc
GTIN	
GTIN	4055626370880

Technical data

Dimensions

Height	56 mm
Width	30 mm
Length	63.5 mm

Ambient conditions

Degree of protection (IP)	IP66
	IP67
Ambient temperature (operation)	-40 °C ... 125 °C

General

Note	For contact inserts HC-D15, A10
Size	D15
Housing type	Sleeve housing
Color	gray aluminum
Locking type	for single locking latch
No. of cable outlets	1
Cable outlet	straight
Screw connection	none
Type of the screw connection	1x Pg13,5

Housing - HC-STA-D15-HLFS-1TTP13-ELC-AL - 1424352

Technical data

General

Housing material	Die-cast aluminum, salt water resistant
Housing surface material	uncoated
Seal material	NBR, conductive

Environmental Product Compliance

China RoHS	Environmentally Friendly Use Period = 50
	For details about hazardous substances go to tab "Downloads", Category "Manufacturer's declaration"

Drawings

Dimensional drawing

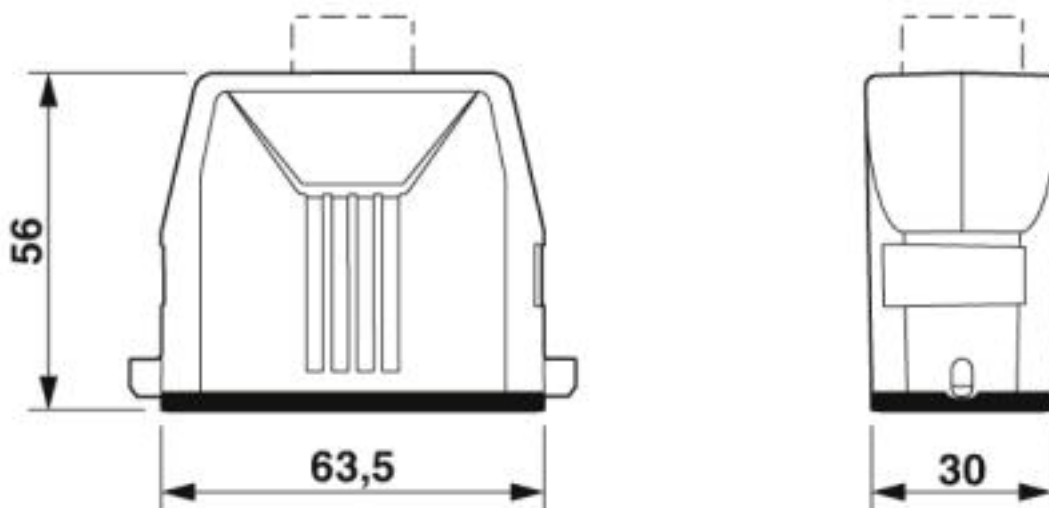

Dimensional drawing

Approvals

Approvals

Approvals

EAC / UL Recognized / cUL Recognized / DNV GL / cULus Recognized

Ex Approvals

Approval details

Housing - HC-STA-D15-HLFS-1TTP13-ELC-AL - 1424352

Approvals

EAC		EAC-Zulassung
-----	---	---------------

UL Recognized		http://database.ul.com/cgi-bin/XYV/template/LISEXT/1FRAME/index.htm	E255026
---------------	---	---	---------

cUL Recognized		http://database.ul.com/cgi-bin/XYV/template/LISEXT/1FRAME/index.htm	E255026
----------------	---	---	---------

DNV GL		https://approvalfinder.dnvgl.com/	TAE000037S
--------	---	---	------------

cULus Recognized			
------------------	---	--	--

Phoenix Contact 2019 © - all rights reserved
<http://www.phoenixcontact.com>

PHOENIX CONTACT GmbH & Co. KG
Flachsmarktstr. 8
32825 Blomberg
Germany
Tel. +49 5235 300
Fax +49 5235 3 41200
<http://www.phoenixcontact.com>