

Figure 1.1. The physical photo of ATH10KBL2A

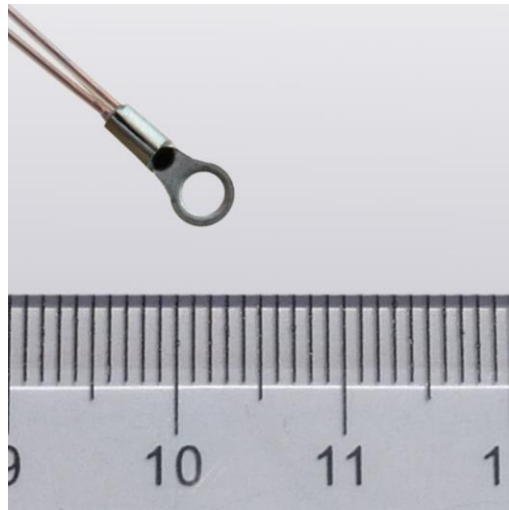

Figure 1.2. The physical photo of ATH10KBL2AT65S

MAIN FEATURES

Glass Encapsulated for Long Term Stability & Reliability

High Stability: $<0.1^{\circ}\text{C}/\text{Y}$

High Resistance Accuracy: 1%

Wide Temp. Range: -55°C to 250°C

Packaged in Extra Small Ring Lug

100 % Lead (Pb)-free and RoHS Compliant

APPLICATIONS

Temperature sensing for laser diodes, optical components, etc.

Note: This thermistor ATH10KBL2A is a replacement for ATH10KL2A.

DESCRIPTION

The ATH10KBL2A is a thermistor assembly with a glass encapsulated thermistor packaged in an extra compact ring lug. The ATH10KBL2A series thermistor consists of three

versions, ATH10KBL2A, ATH10KBL2AT65 and ATH10KBL2AT65S. The ATH10KBL2A has bare leads coated with copper, the ATH10KBL2AT65S has the leads covered by high temperature plastic tubing and sealed by epoxy, while the ATH10KBL2AT65 is the non-sealed version. Compared with conventional assemblies containing epoxy encapsulated thermistors, ATH10KBL2A presents higher long term stability, higher reliability and wider temperature range. In addition, it is compact size and has a short response time.

The ATH10KBL2A series thermistor can be used to measure the temperatures of laser diodes, optical components, etc., with high accuracy and long term stability.

There are some differences among ATH10KBL2A, ATH10KL2B and ATH10KL2C. First, the ring sizes are different. Second, the thermistor head in ATH10KBL2A is the same as ATH10KR8B, while the heads in ATH10KL2B and ATH10KL2C are the same as ATH10K1R25. Last, the resistance temperature characteristics in ATH10KL2B and ATH10KL2C are the same, but different from ATH10KBL2A.

SPECIFICATIONS

Parameters	Value	
	ATH10KBL2A	ATH10KL2A
Nominal Resistance @ 25°C	$10\text{K} \pm 1\%$	$10\text{K} \pm 1\%$
B Value @ $25^{\circ}\text{C}/85^{\circ}\text{C}$	$3478\text{K} \pm 1\%$	$3480\text{K} \pm 1\%$
B Value @ $0^{\circ}\text{C}/100^{\circ}\text{C}$	$3450\text{K} \pm 1\%$	$3450\text{K} \pm 1\%$
B Value @ $25^{\circ}\text{C}/100^{\circ}\text{C}$	$3492\text{K} \pm 1\%$	$3497\text{K} \pm 1\%$
Ring Lug Length	$8.1 \pm 0.1\text{mm}$	$8.1 \pm 0.1\text{mm}$
Ring Lug Width	$3.6 \pm 0.1\text{mm}$	$3.6 \pm 0.1\text{mm}$
Lead Diameter	0.15mm	0.15mm
Lead Length	$65 \pm 3\text{mm}$	$63 \pm 3\text{mm}$
Time Constant	0.14s (in water)	0.14s (in water)
	2~2.2s (in still air @ $5\sim 25^{\circ}\text{C}$)	2~2.2s (in still air @ $5\sim 25^{\circ}\text{C}$)

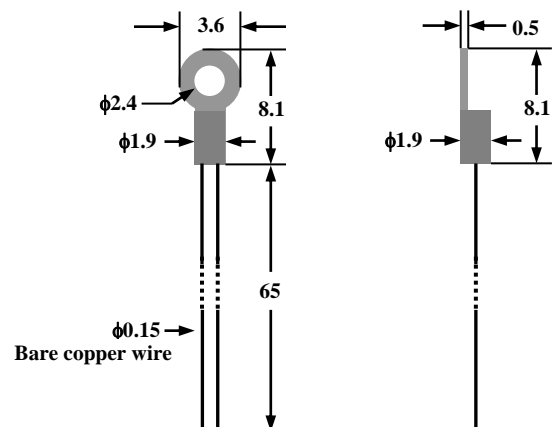

Figure 2. The Front and Side Views of ATH10KBL2A



APPLICATION

Use #2 imperial or M2.5 metric screw to mount the thermistor assembly onto a smooth metal surface of the object for which the temperature needs to be measured.

The thermistor lead wires are made of plain copper, make sure that they do not touch each other, nor any other electrically conductive objects.

For high precision applications, use a cover which is made of thermal isolation material to cover the thermistor area, see Figure 3. In this way, the air flow will not affect the temperature sensing accuracy.

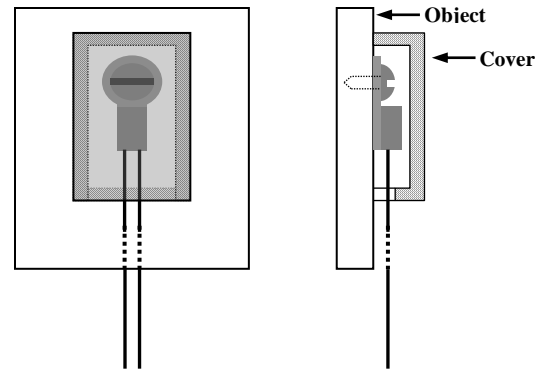

Figure 3. Using an Insulation Cover to Improve Accuracy

Resistance Temperature Characteristics

Table 1. ATH10KBL2A vs. ATH10KL2A

T (°C)	R _{nom} (Ω)		T (°C)	R _{nom} (Ω)	
	ATH10KBL2A	ATH10KL2A		ATH10KBL2A	ATH10KL2A
-55	526240	519911	50	4100	4103
-50	384520	379894	55	3479.8	3482
-45	284010	280697	60	2966.3	2967
-40	211940	209603	65	2539.2	2539
-35	159720	158088	70	2182.4	2182
-30	121490	120372	75	1883	1882
-25	93246	92484	80	1630.7	1629
-20	72181	71668	85	1417.4	1415
-15	56332	55993	90	1236.2	1234
-10	44308	44087	95	1081.8	1079
-5	35112	34971	100	949.73	946.6
0	28024	27936	105	836.4	833.1
5	22520	22468	110	738.81	735.5
10	18216	18187	115	654.5	651.1
15	14827	14813	120	581.44	578.1
20	12142	12136	125	517.94	514.6
25	10000	10000	130	462.59	459.4
30	8281.8	8284	135	414.2	411.1
35	6895.4	6899	140	371.79	368.8
40	5770.3	5774	145	334.51	331.6
45	4852.5	4856	150	301.66	298.9



T (°C)	R _{nom} (Ω)		T (°C)	R _{nom} (Ω)	
	ATH10KBL2A	ATH10KL2A		ATH10KBL2A	ATH10KL2A
155	272.64	270.0	205	110.51	109.1
160	246.94	244.4	210	101.94	100.7
165	224.14	221.7	215	94.181	93.01
170	203.85	201.6	220	87.144	86.08
175	185.77	183.6	225	807.51	79.78
180	169.61	167.6	230	74.933	74.05
185	155.14	153.3	235	69.631	68.83
190	142.16	140.4	240	64.791	64.08
195	130.49	128.9	245	60.366	59.73
200	119.99	118.5	250	56.316	55.75

Table 2. α (Temperature coefficient at T in %/K)—ATH10KBL2A

T (°C)	α (%/K)	T (°C)	α (%/K)	T (°C)	α (%/K)
-55	6.4	50	3.3	155	2.0
-50	6.2	55	3.2	160	2.0
-45	6.0	60	3.2	165	1.9
-40	5.8	65	3.1	170	1.9
-35	5.6	70	3.0	175	1.8
-30	5.4	75	2.9	180	1.8
-25	5.2	80	2.8	185	1.8
-20	5.0	85	2.8	190	1.7
-15	4.9	90	2.7	195	1.7
-10	4.7	95	2.6	200	1.7
-5	4.6	100	2.6	205	1.6
0	4.4	105	2.5	210	1.6
5	4.3	110	2.5	215	1.6
10	4.2	115	2.4	220	1.5
15	4.1	120	2.3	225	1.5
20	3.9	125	2.3	230	1.5
25	3.8	130	2.2	235	1.5
30	3.7	135	2.2	240	1.4
35	3.6	140	2.1	245	1.4
40	3.5	145	2.1	250	1.4
45	3.4	150	2.0		



NOTICE

1. ATI reserves the right to make changes to its products or to discontinue any product or service without notice, and advise customers to obtain the latest version of relevant information to verify, before placing orders, that information being relied on is current and complete.
2. All products are sold subject to the terms and conditions of sale supplied at the time of order acknowledgment, including those pertaining to warranty, patent infringement, and limitation of liability. Testing and other quality control techniques are utilized to the extent ATI deems necessary to support this warranty. Specific testing of all parameters of each device is not necessarily performed, except those mandated by government requirements.
3. Customers are responsible for their applications using ATI components. In order to minimize risks associated with the customers' applications, adequate design and operating safeguards must be provided by the customers to minimize inherent or procedural hazards. ATI assumes no liability for applications assistance or customer product design.
4. ATI does not warrant or represent that any license, either expressed or implied, is granted under any patent right, copyright, mask work right, or other intellectual property right of ATI covering or relating to any combination, machine, or process in which such products or services might be or are used. ATI's publication of information regarding any third party's products or services does not constitute ATI's approval, warranty or endorsement thereof.
5. IP (Intellectual Property) Ownership: ATI retains the ownership of full rights for special technologies and/or techniques embedded in its products, the designs for mechanics, optics, plus all modifications, improvements, and inventions made by ATI for its products and/or projects.