



ENGINEERING SPECIFICATION

INSTALLATION INSTRUCTION SHEETS

1.0 SCOPE

This specification consists of installation instructions for the Self Contained Power Connector for tap splice.

2.0 PURPOSE

To define material number system for the above instructions.

3.0 REFERENCE MATERIAL NUMBERS

See pages 2-3 for the actual instruction sheets. These pages can be used as originals.

4.0 DEFINITIONS

Not applicable.

5.0 PROCEDURES

Place one (1) instruction sheet in the smallest unit container.

6.0 IMPLEMENTATION

December 6, 2005

REVISION: D	ECR/ECN INFORMATION: EC No: WNA2009-0564 DATE: 2009 / 03 / 04	TITLE: SELF CONTAINED POWER CONNECTOR INSTALLATION INSTRUCTIONS FOR TAP SPLICE	SHEET No. 1 of 3
DOCUMENT NUMBER: SD-19402-004	CREATED / REVISED BY: ETHRODAHL	CHECKED BY: JMACNEIL	APPROVED BY: JMACNEIL

COC-3 Self Contained Power Connector Installation Instructions For Tap Splice

The 2-circuit-with-ground tap connector is used to tap non-metallic-sheathed cable in the following wire ranges and types:

Wire Range AWG	Description	Order No.	Optional Bench Arbor Press	Optional Hand Tool
12-14	Self Contained Power Tap Connector - 2 circuit w/ ground for solid wire	19402-1000 (COC-3)	64006-0200	19285-0074



Reference Information

UL File Number: E182087
 CSA File Number: LR18689-C53
 NEC Article: 550, 551, and 545
 HUD Section: 3280.801
 Current: 20A
 Voltage: 300V

Installation Procedure:

1. Carefully strip sheath and paper coverings and prepare the wires to the configuration as shown in **Figure 1**. For reference in the absence of a measuring tool, the distance shown in **Figure 1.1** is approximately equal to strip length.
2. Hold the clear strain relief cover with bottom facing upward as shown in **Figure 2**.
3. Lay wire into locator slots, making sure the black wire is placed into locator slots marked BLK shown in **Figure 2**. Use the two wire locators and spreaders to help guide the wire into place. Press the cable sheath into the integral strain relief slot.
4. While holding the strain relief cover, position the housing's hinge posts into the hinge slots and press down until both lock into place as shown in **Figure 2**.
5. Close the strain relief cover and housing by hand. Place the connector assembly into Molex tool as shown in **Figure 3**. Squeeze the tool until the connector bottoms out and the locking latches engage on both sides. OR alternately, squeeze the top and bottom closed with tongue and groove pliers as shown in **Figure 3.1**. Pliers must be a minimum of 10" long. Squeeze firmly on both sides, squarely across the connector with the bottom jaw of the pliers butted up against the T-extension in the housing to ensure wires seat completely into slots.
6. Inspect the connector to ensure the wires have been properly engaged into the housing assembly contacts. A properly terminated wire is fully seated into its proper slots with no significant bow of the cover. *If the wires are not properly seated into the housing assembly contacts, the wires must be re-terminated with a NEW CONNECTOR. Once the cover has been closed the connector cannot be re-used. Failure to comply with this procedure may result in the failure of the connector.*

Fig. 1 Cable prep

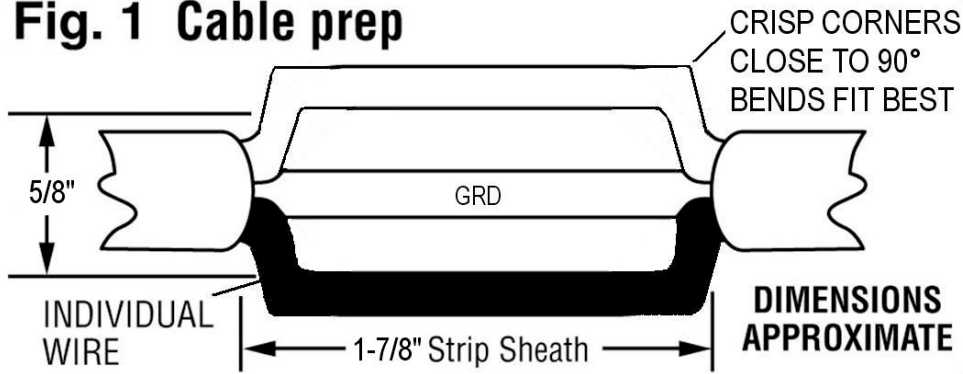

Fig. 1.1

Reference Dimension for Strip Length

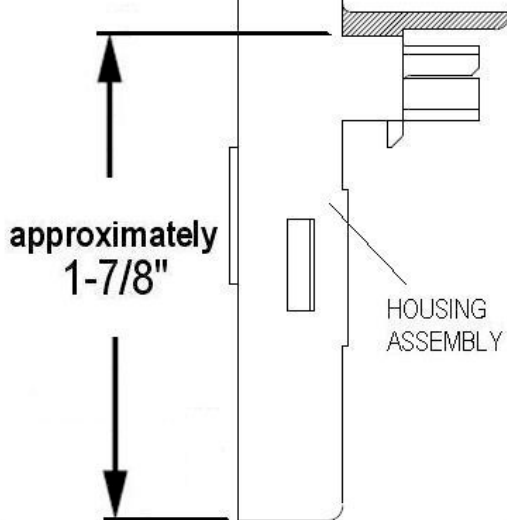

Fig. 2 Attach housing to strain relief.

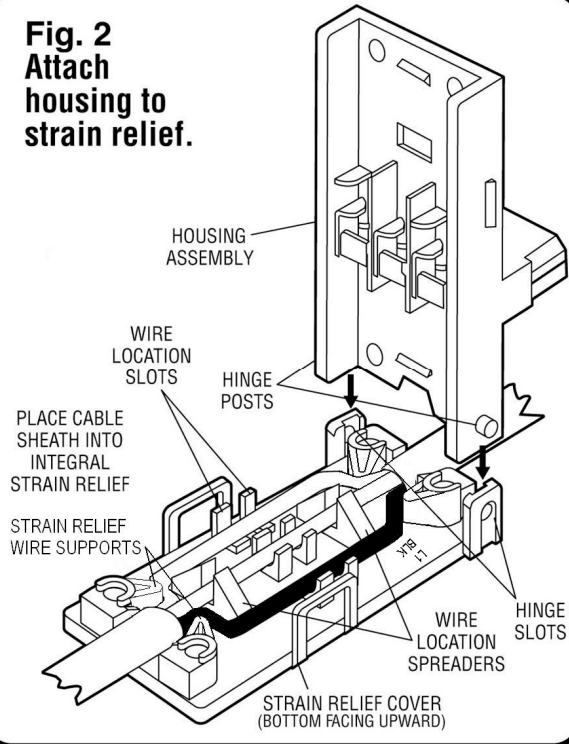

FIG. 3.1 Alternately, clamp connector with tongue & groove pliers, squeezing squarely and firmly approximately as shown.

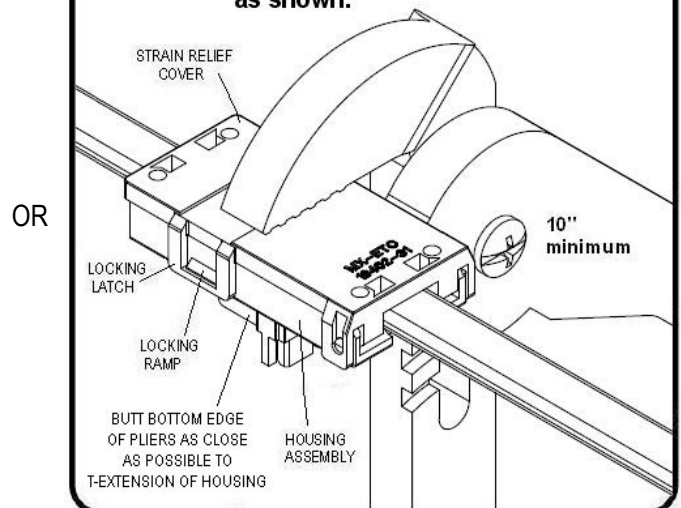
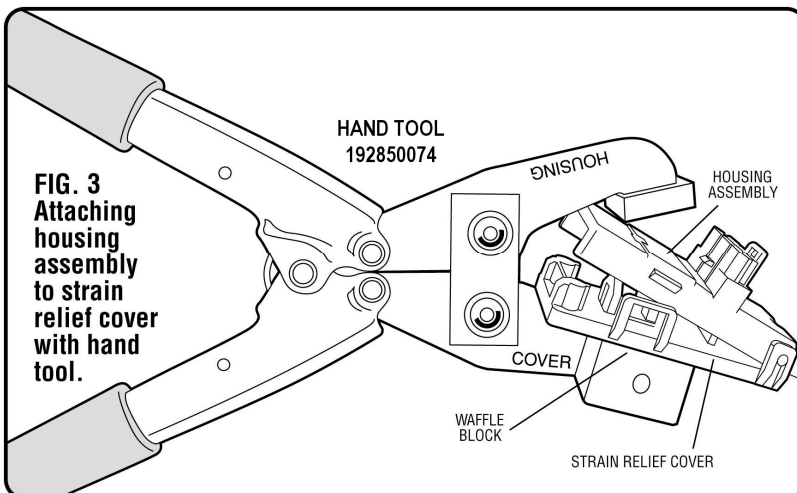
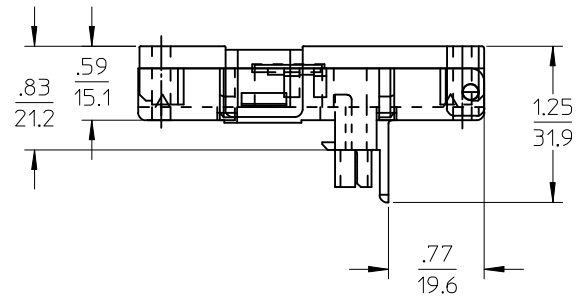
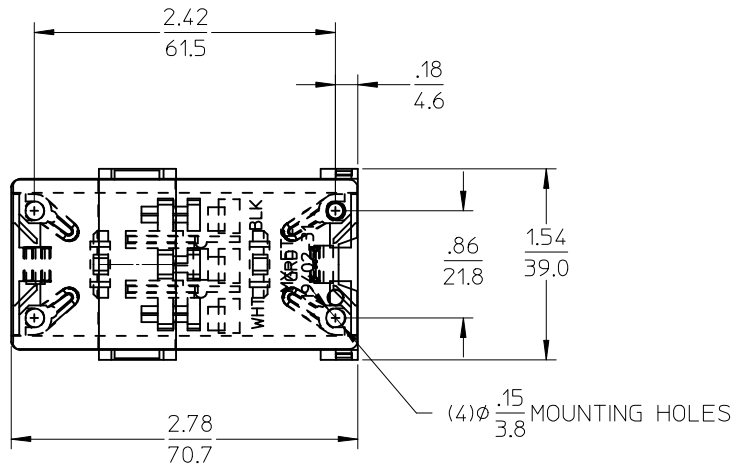

FIG. 3 Attaching housing assembly to strain relief cover with hand tool.



10	9	8	7	6	5	4	3	2	19402
MATERIAL NO.	ENGINEERING P/N								
194021000	COC-3								



ASSEMBLED VIEWS

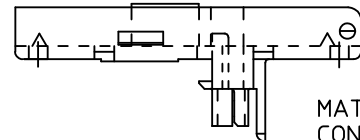
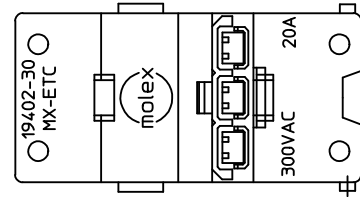

HOUSING ASSEMBLY
MATERIAL NUMBER 19402-2000
CONTAINING HOUSING P/N 19402-3000,
COLOR NATURAL

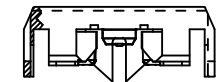
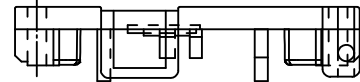
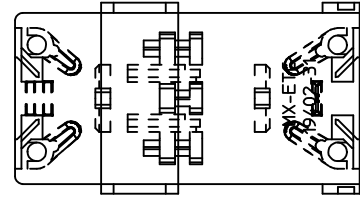

COVER
MATERIAL NUMBER 19402-3110, CLEAR

- NOTES:
- PARTS ARE PACKAGED 50 UNITS PER CONTAINER.
 - REF: UL FILE NO. E182087, CSA FILE NO. LR18689.
 - PARTS ARE ROHS COMPLIANT.

CHANGE COVER P/N EC NO: WNA2009-0564 DRW: WNETHRODAHL 2009/05/22 CHKD: JMAGNE IL 2009/05/22 APPR: JMAGNE IL 2009/05/22	QUALITY SYMBOLS ▽=0 ▽=0	GENERAL TOLERANCES (UNLESS SPECIFIED)		DIMENSION STYLE IN/MM		SCALE 1:1	DESIGN UNITS INCH	THIRD ANGLE PROJECTION		
		4 PLACES ± --- ± ---	DRAWN BY DAY	DATE 1997/05/27	TITLE CUSTOMER DRAWING COC-3 SC TAP CONNECTR ASSEMBLY 12-14AWG SOLID 2/C+GRD					
		3 PLACES ± --- ± .005	CHECKED BY RDEROSS	DATE 1997/05/27						
		2 PLACES ± 0.13 ± .01	APPROVED BY RDEROSS	DATE 1997/05/27	Molex MOLEX INCORPORATED		MATERIAL NO.	DOCUMENT NO. SD-19402-105	SHEET NO. 1 OF 1	
1 PLACE ± 0.25 ± ---	DRAFT WHERE APPLICABLE MUST REMAIN WITHIN DIMENSIONS		SEE CHART		THIS DRAWING CONTAINS INFORMATION THAT IS PROPRIETARY TO MOLEX INCORPORATED AND SHOULD NOT BE USED WITHOUT WRITTEN PERMISSION					
ANGULAR ± ---										