

2.50 ±0.25
(SIGNAL TAILS)

1.58 MIN
(PCB THICKNESS)

14.4

(13.38)
SCREW HOLE DEPTH

ALLOW EXTRA SPACE
4.00 MM PER SIDE
(REQUIRED FOR RE-WORK PER AS-46436-100)

SECTION B-B (A1)

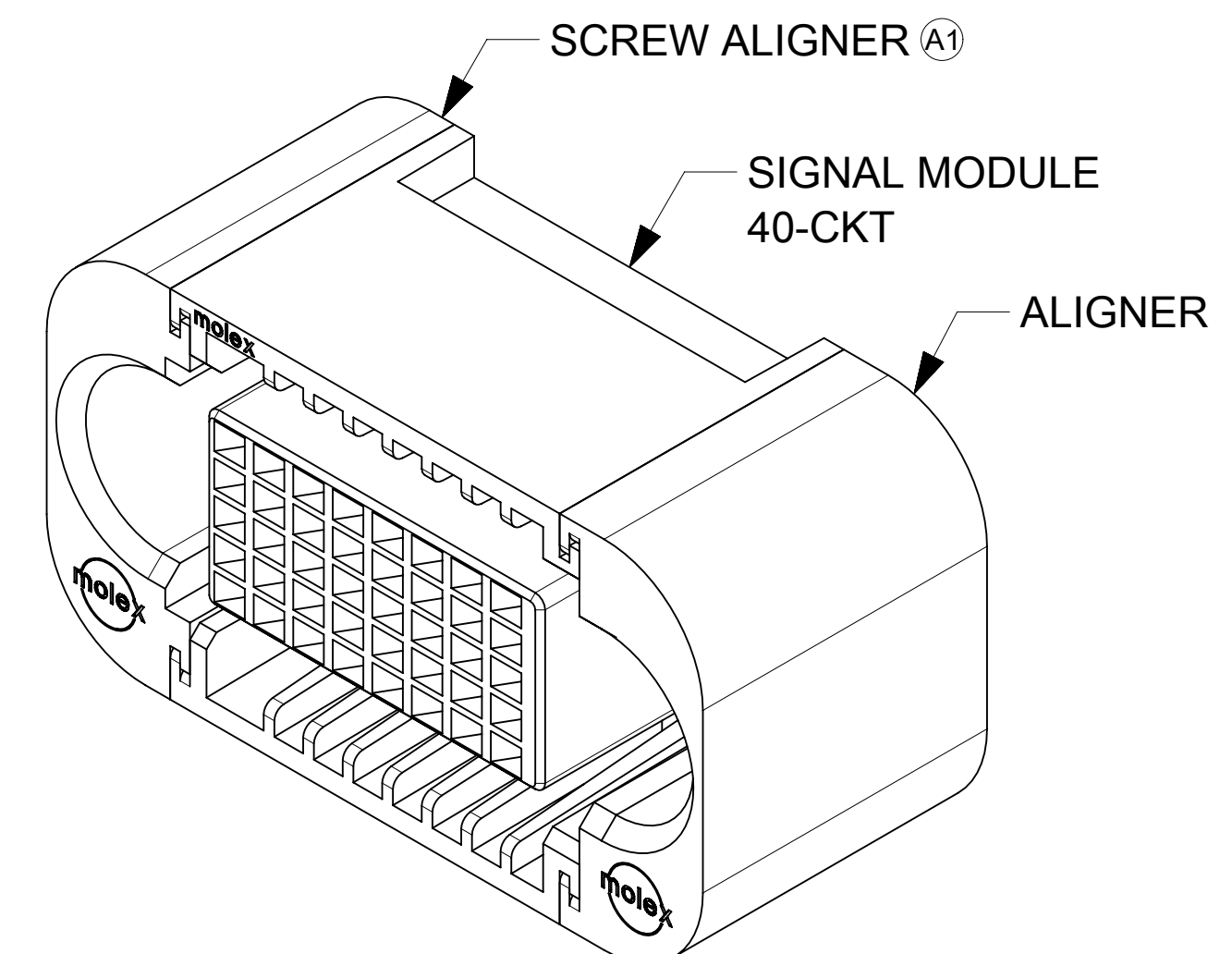
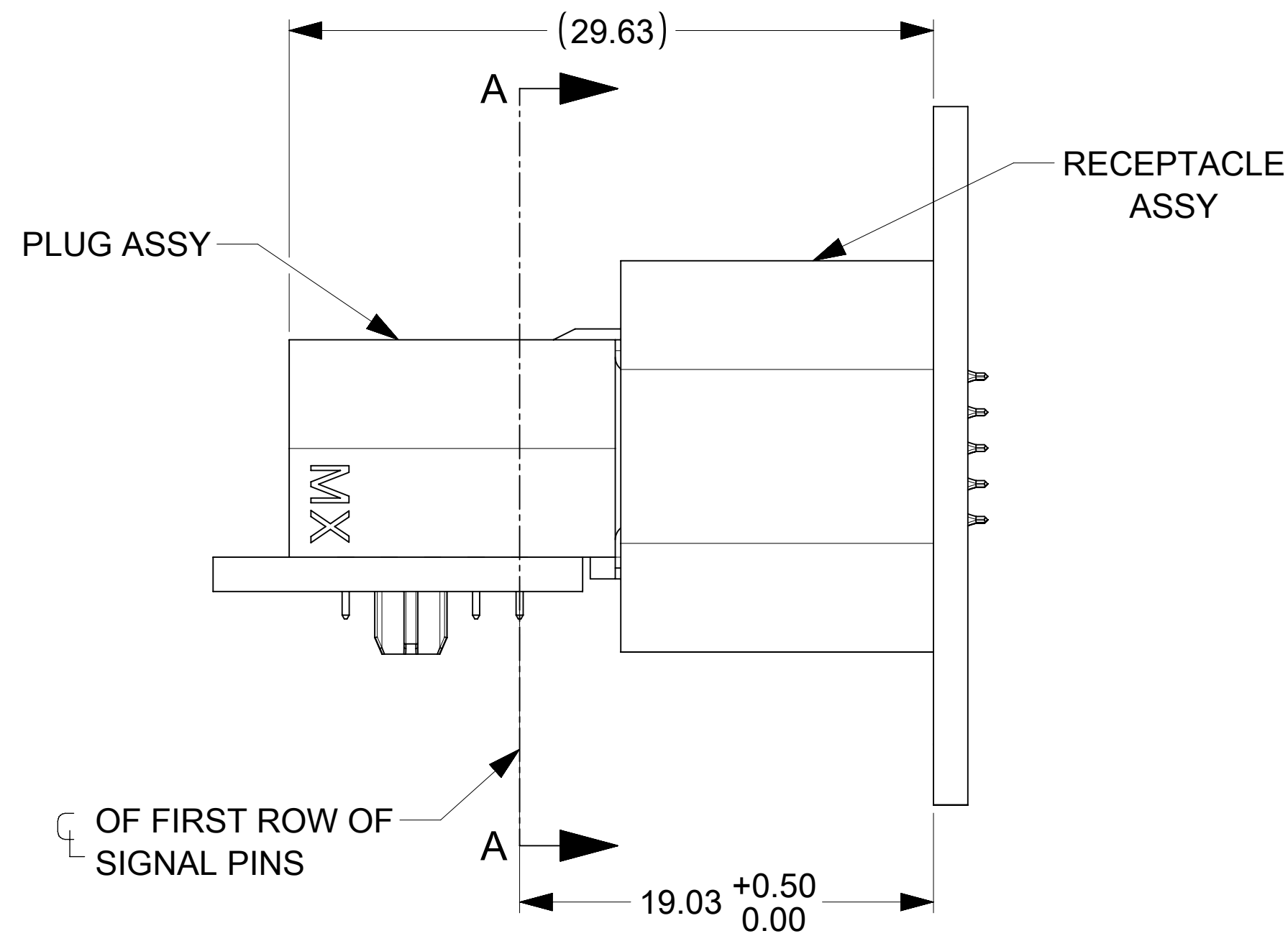
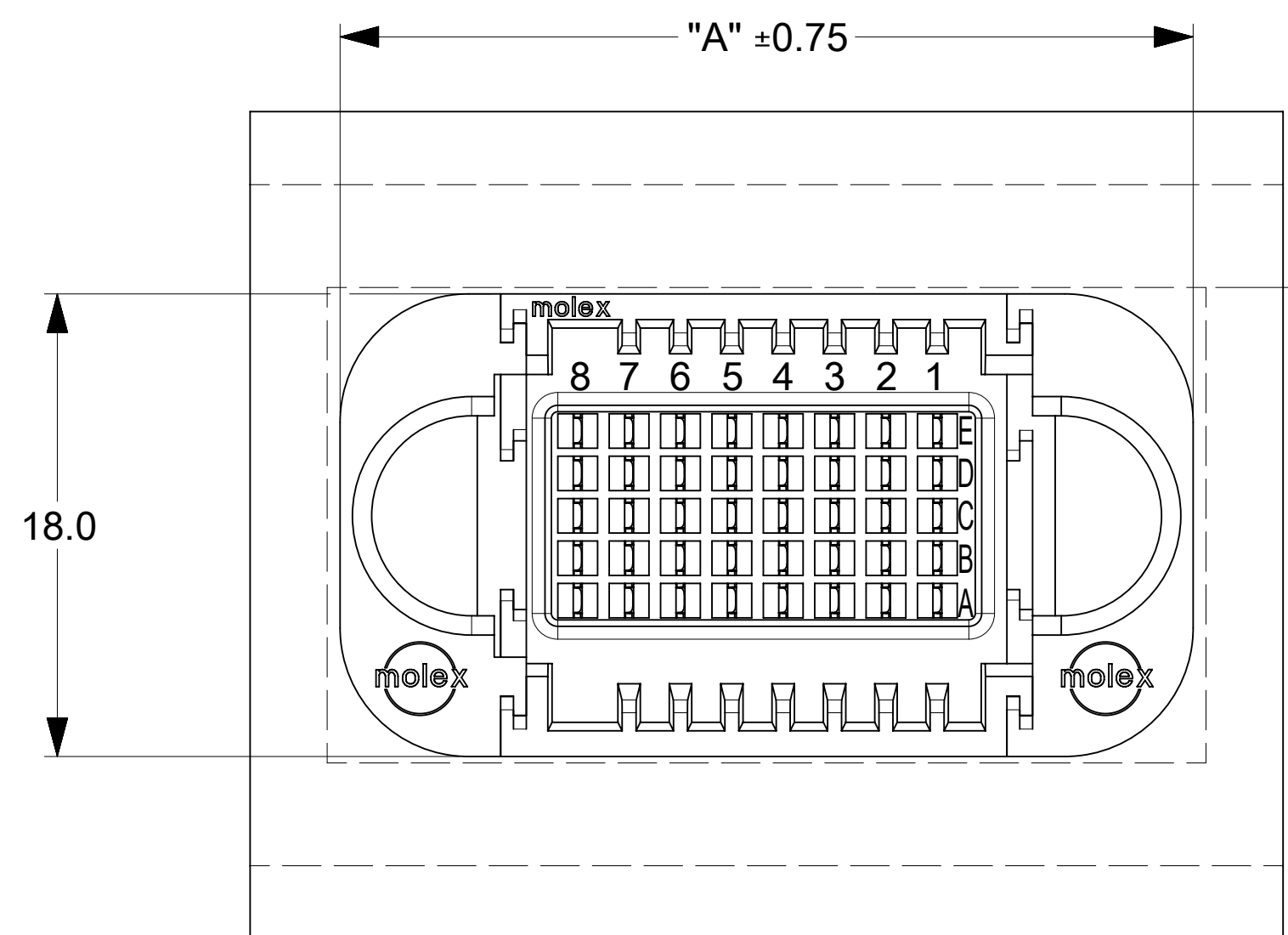

P/N: 46562-3133 (G-40S-G)

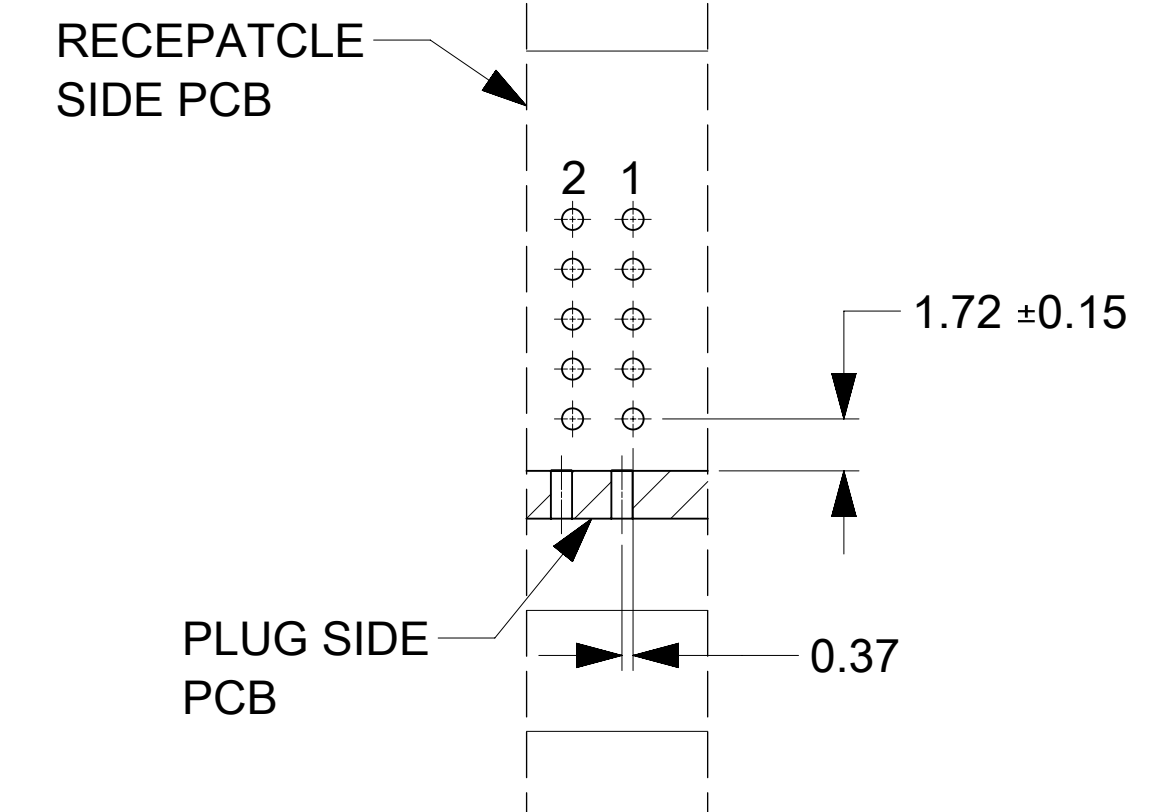

PARTIAL OF A-A
(SIGNAL CKTS ARE ALIGNED)

MATED PROFILE

NOTES:

1. MATERIAL:
 - HOUSINGS: LCP UL94, V-0, COLOR: BLACK
 - TERMINALS: COPPER ALLOY
 - PLATING: 1.27 MICROMETER (50 MICROINCH) NICKEL OVERALL WITH 2.54 MICROMETER (100 MICROINCH) SELECTIVE TIN ON TAILS AND 0.762 MICROMETER (30 MICROINCH) SELECTIVE GOLD ON CONTACT AREA
2. PACKAGING: ASSEMBLIES TO BE TRAY PACKED PER PACKAGING SPEC: 465621001-PK
3. PLATED THRU HOLE SIZE, REFER TO PS-46436-100 FOR DETAILS
4. PRODUCT SPEC: PS-46436-100.
5. APPLICATION SPEC: AS-46436-100
6. PRODUCT TO MEET RoHS REQUIREMENTS
7. ASSEMBLY MATES TO MOLEX PLUG ASSEMBLY P/N 46437-**** (SEE TABLE IN SHEET 2).
8. TAIL DESIGN: COMPLIANT PIN
9. SIGNAL CONTACTS ARE LUBRICATED.
10. MOLEX LOGO TO BE LOCATED APPROXIMATELY AS SHOWN
11. FOR USE WITH 2-32 TYPE AB SELF THREADING SCREWS, SCREW LENGTH OF 9.50MM IS RECOMMENDED FOR 1.58MM THICK PCB MAX TORQUE IS 4IN-LBS

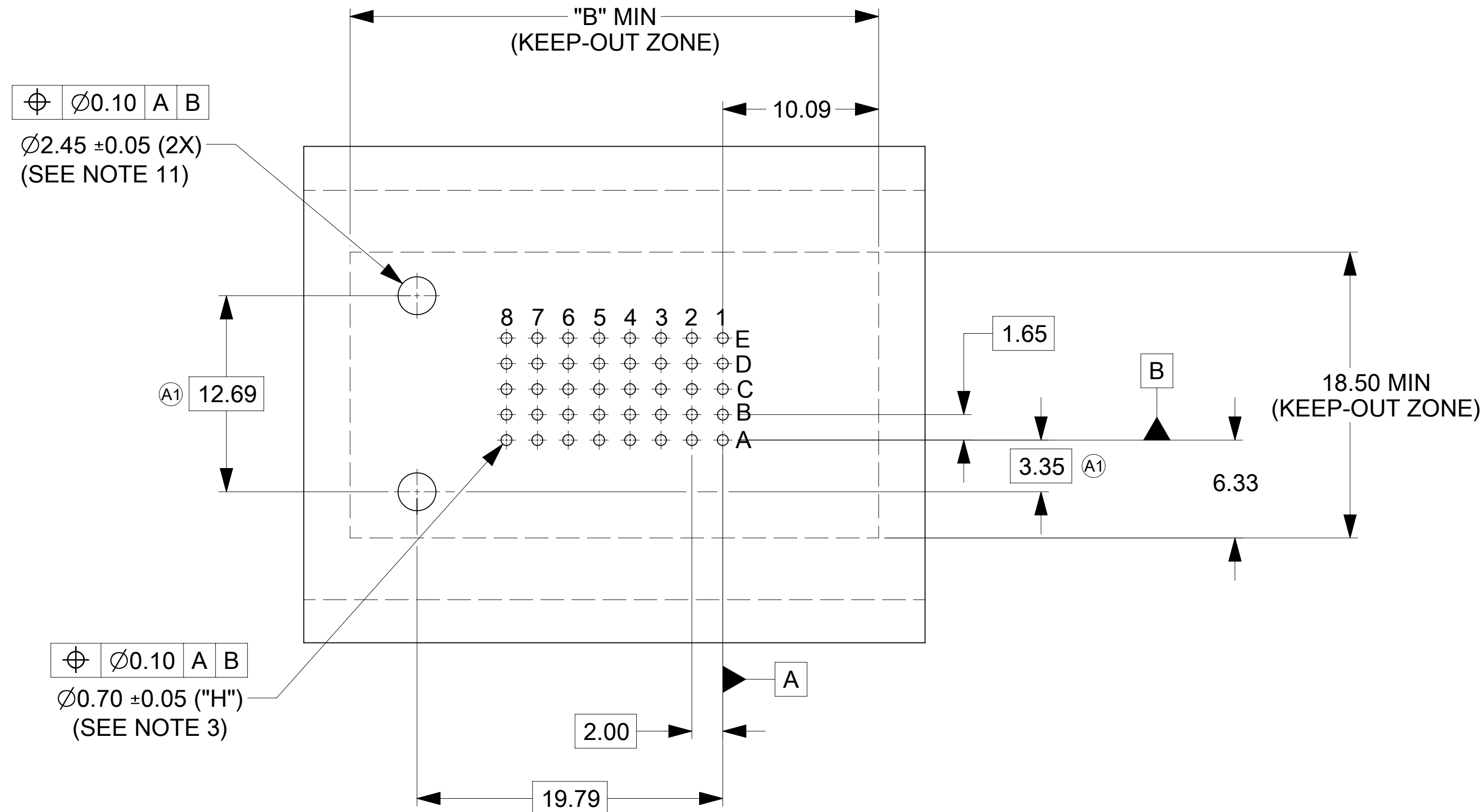

RECOMMENDED PCB LAYOUT AND KEEP-OUT ZONE
FOR G-(10S TO 40S)-G

THIS DRAWING CONTAINS INFORMATION THAT IS PROPRIETARY TO MOLEX ELECTRONIC TECHNOLOGIES, LLC AND SHOULD NOT BE USED WITHOUT WRITTEN PERMISSION

DIMENSION UNITS: mm		SCALE: 4:1		CURRENT REV DESC: REPLACED STANDARD ALIGNER WITH SCREW DOWN ALIGNER, UPDATED DIMENSIONS & ADDED SECTION VIEW B-B		molex	
GENERAL TOLERANCES (UNLESS SPECIFIED)		ANGULAR TOL ± 0.5°		EC NO: 729882			
4 PLACES ±		3 PLACES ±		2 PLACES ± 0.13		PRODUCT CUSTOMER DRAWING	
1 PLACE ± 0.25		0 PLACES ±		INITIAL REVISION:		DOCUMENT NUMBER	
DRAFT WHERE APPLICABLE MUST REMAIN WITHIN DIMENSIONS		THIRD ANGLE PROJECTION		DRAWING		DOC TYPE	
D-SIZE		SERIES		MATERIAL NUMBER		DOC PART	
46562		46562		CUSTOMER		REVISION	
SEE TABLE		GENERAL MARKET		465623127		PSD 000 A1	
SHEET NUMBER		1 OF 2					

REFER TO BELOW TABLE FOR DIMENSIONS.

FG P/N	CONFIGURATION	SIGNAL CKT SIZE	DIM "A" (IN MM)	DIM "B" (IN MM) ^(A1)	HOLES COUNT "H"	MATES WITH R/A PLUG ASSY P/N - COMPLIANT PIN
46562-3127	G-10S-G	10	21.21	22.21	10	46437-3127
46562-3128	G-15S-G	15	23.21	24.21	15	46437-3128
46562-3129	G-20S-G	20	25.21	26.21	20	46437-3129
46562-3130	G-25S-G	25	27.21	28.21	25	46437-3130
46562-3131	G-30S-G	30	29.21	30.21	30	46437-3131
46562-3132	G-35S-G	35	31.21	32.21	35	46437-3132
46562-3133	G-40S-G	40	33.21	34.21	40	46437-3133

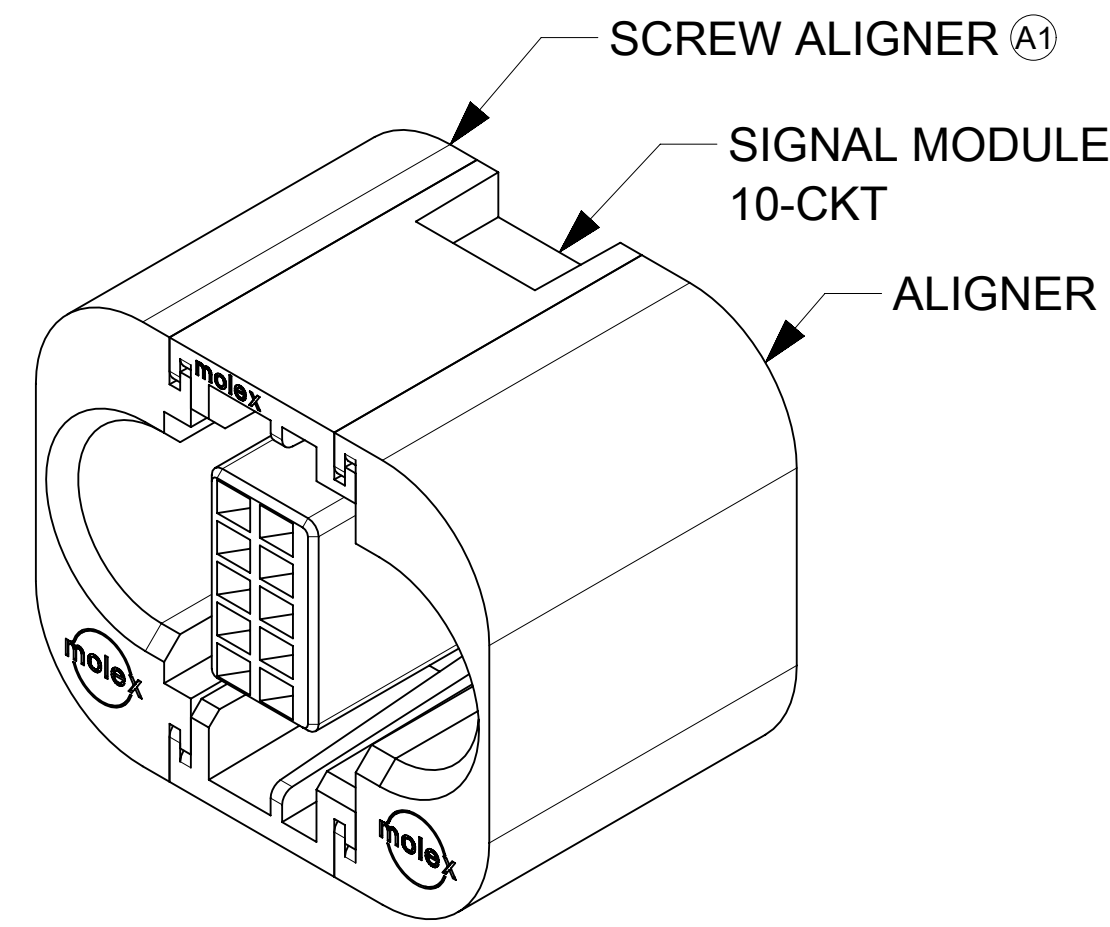

P/N: 46562-3127 (G-10S-G)

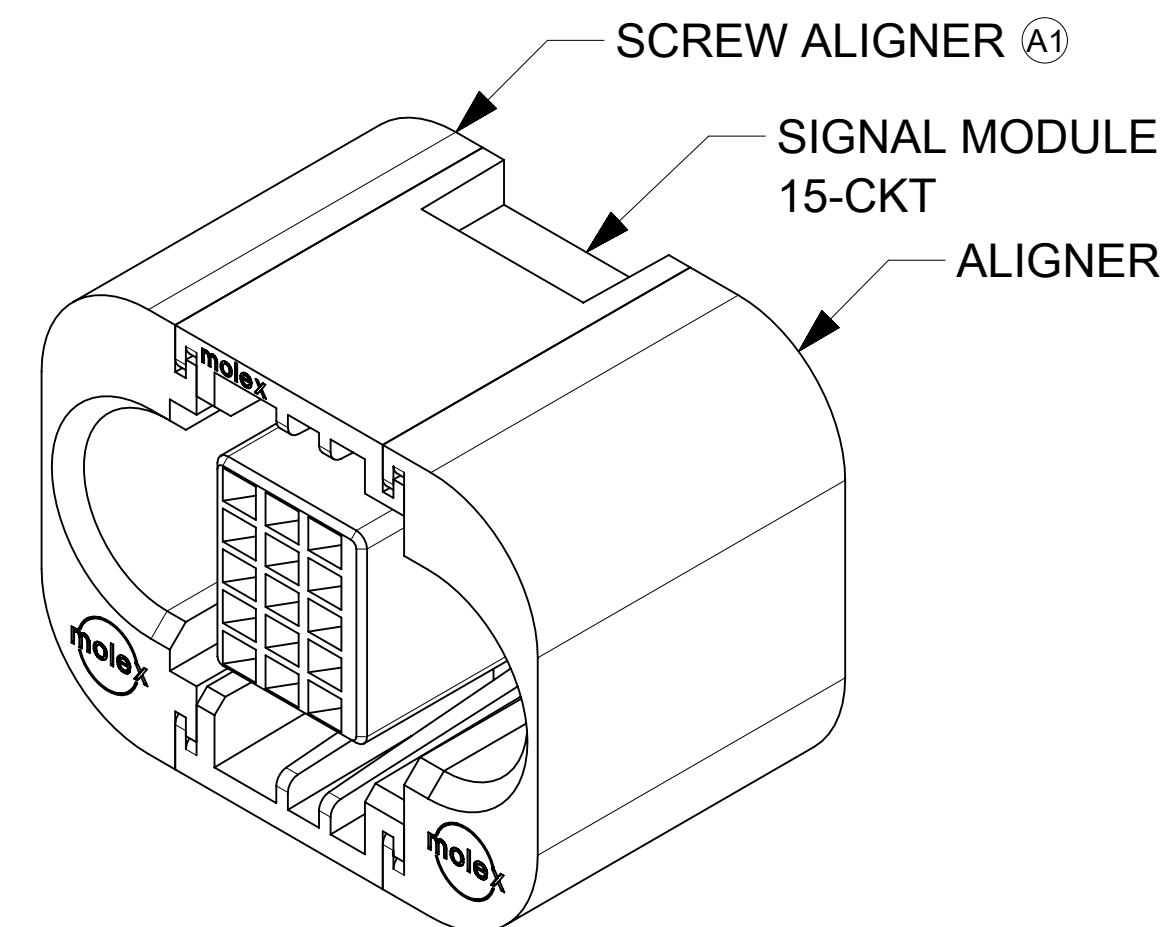

P/N: 46562-3128 (G-15S-G)

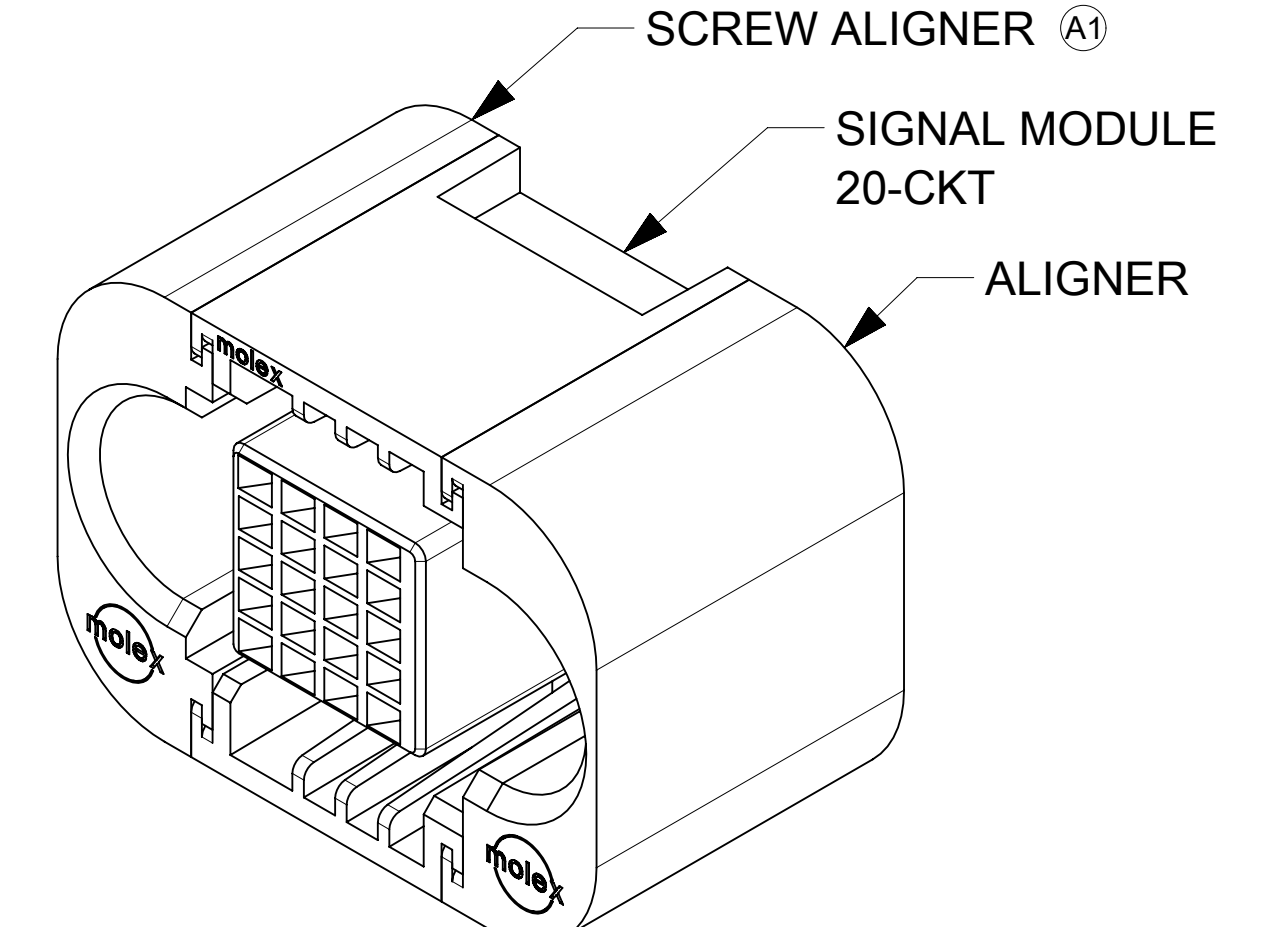

P/N: 46562-3129 (G-20S-G)

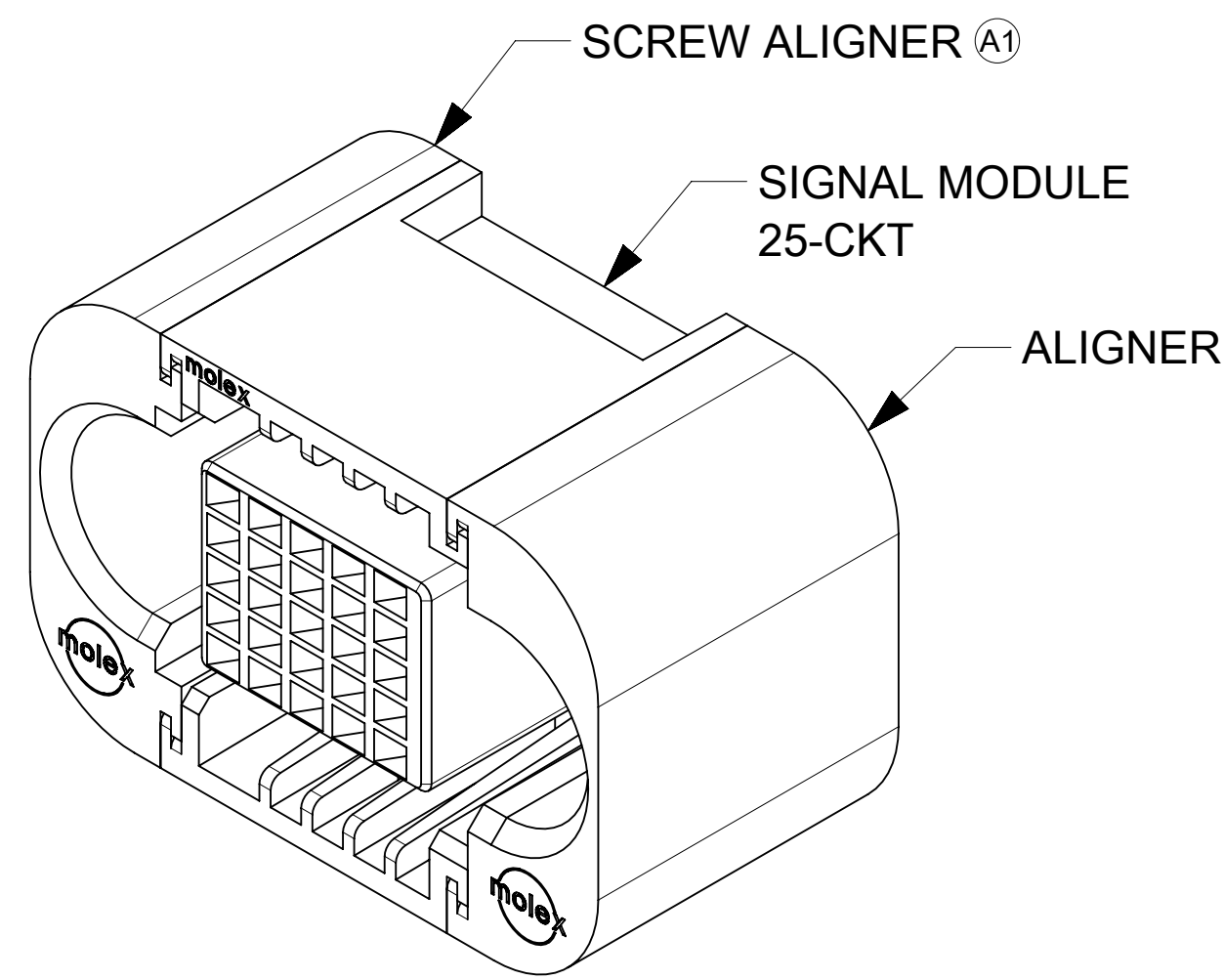

P/N: 46562-3130 (G-25S-G)

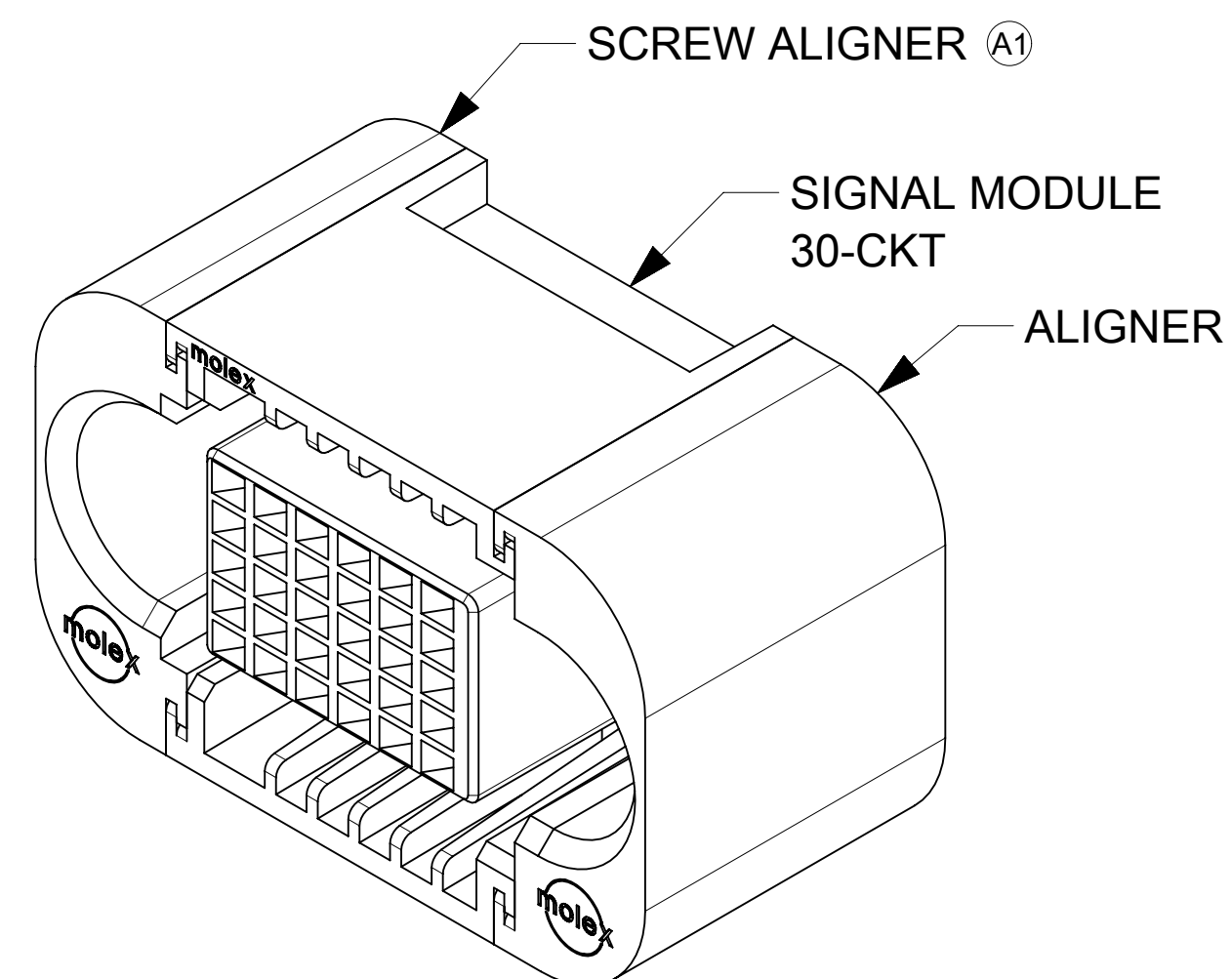

P/N: 46562-3131 (G-30S-G)

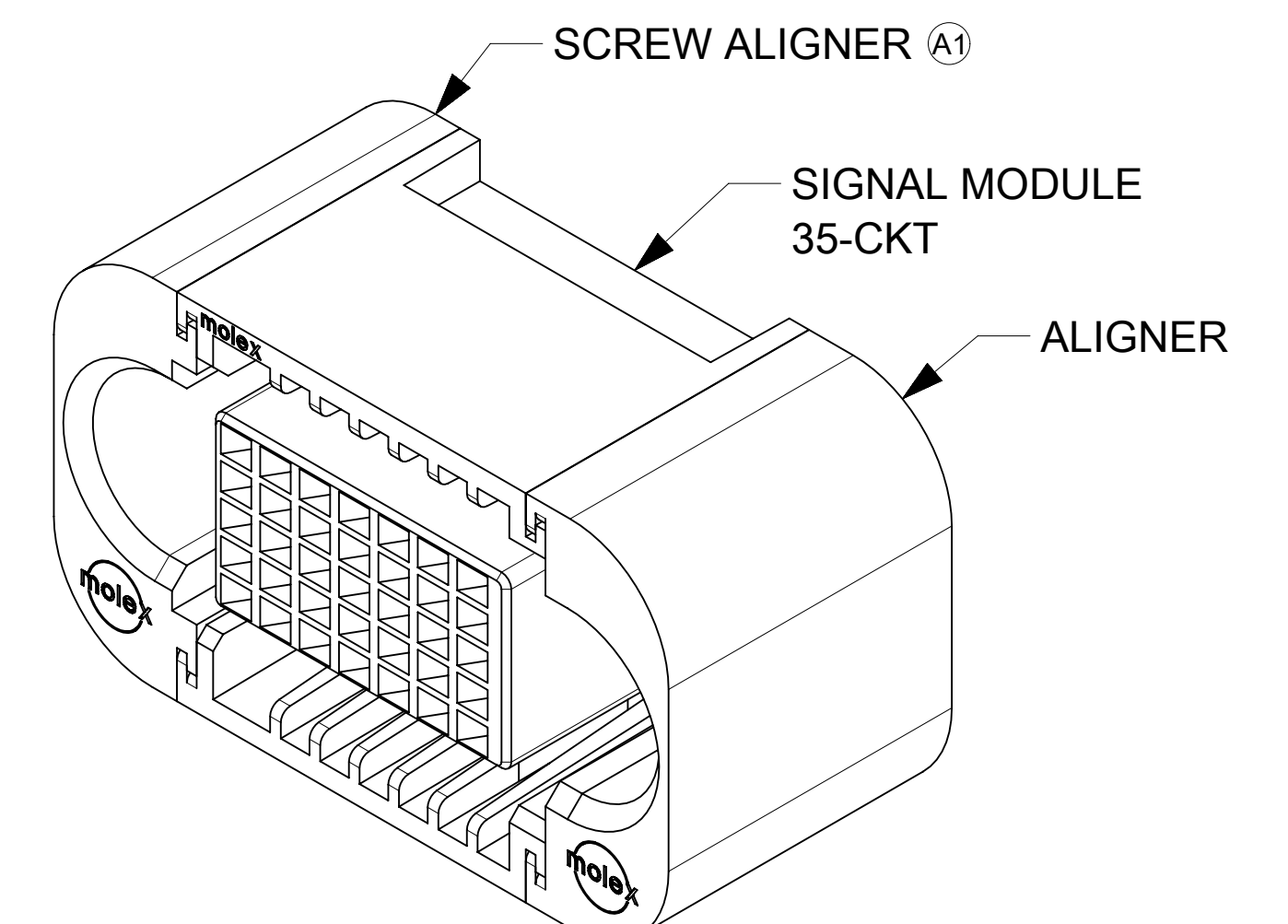

P/N: 46562-3132 (G-35S-G)

THIS DRAWING CONTAINS INFORMATION THAT IS PROPRIETARY TO MOLEX ELECTRONIC TECHNOLOGIES, LLC AND SHOULD NOT BE USED WITHOUT WRITTEN PERMISSION									
DIMENSION UNITS		SCALE		CURRENT REV DESC: REPLACED STANDARD ALIGNER WITH SCREW DOWN ALIGNER, UPDATED DIMENSIONS & ADDED SECTION VIEW B-B					
mm		4:1		<p>molex</p> <p>G-*S-G VERT RECEPTACLE ASSY - TEN60 POWER FAMILY</p> <p>PRODUCT CUSTOMER DRAWING</p>					
GENERAL TOLERANCES (UNLESS SPECIFIED)									
ANGULAR TOL ± 0.5°									
4 PLACES ±		EC NO: 729882							
3 PLACES ±		DRWN: ABHIRK 2022/08/11							
2 PLACES ± 0.13		CHK'D: BHAGAD 2022/08/16							
1 PLACE ± 0.25		APPR: HTHYAGARAJ 2022/12/12							
0 PLACES ±		INITIAL REVISION:							
DRAFT WHERE APPLICABLE MUST REMAIN WITHIN DIMENSIONS		DRWN: GJEEVANSURES 2022/01/12		APPR: HTHYAGARAJ 2022/02/22		DOCUMENT NUMBER		DOC TYPE DOC PART REVISION	
THIRD ANGLE PROJECTION		DRAWING		SERIES		MATERIAL NUMBER		CUSTOMER	
D-DRAWING		46562		SEE TABLE		GENERAL MARKET		SHEET NUMBER	
D-DRAWING		46562		SEE TABLE		GENERAL MARKET		2 OF 2	