

REVISIONS					
P	LTR	DESCRIPTION	DATE	DMN	APVD
W		REVISED PER ECO-16-009924	12JUL2016	DS	SY

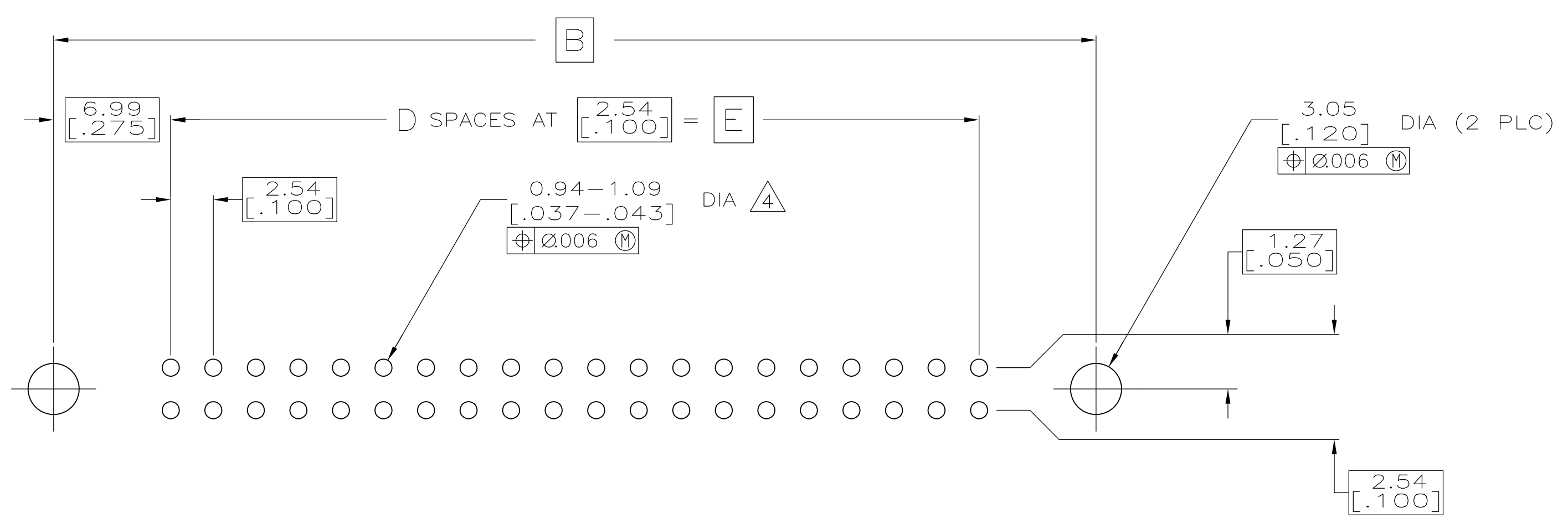
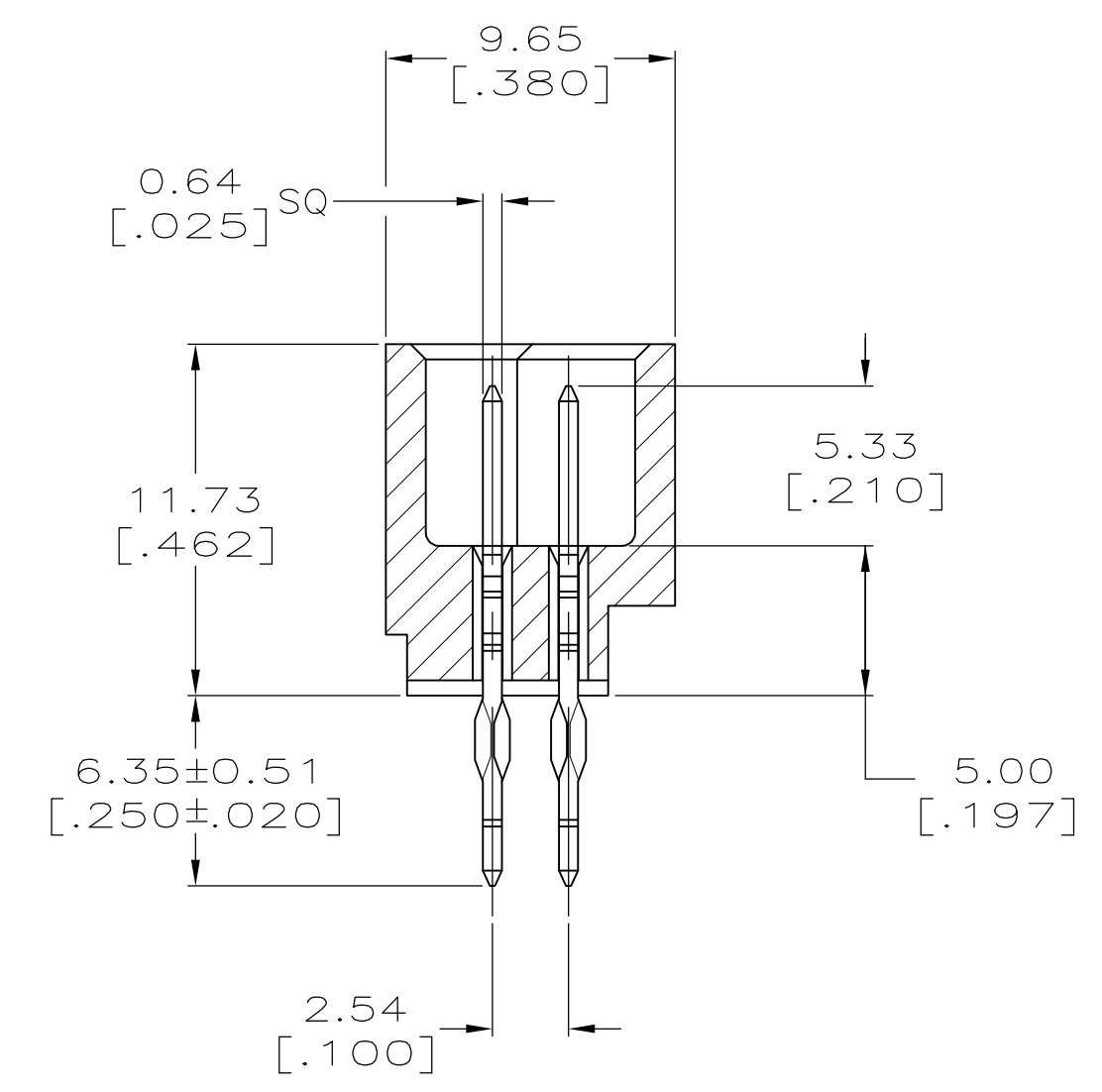
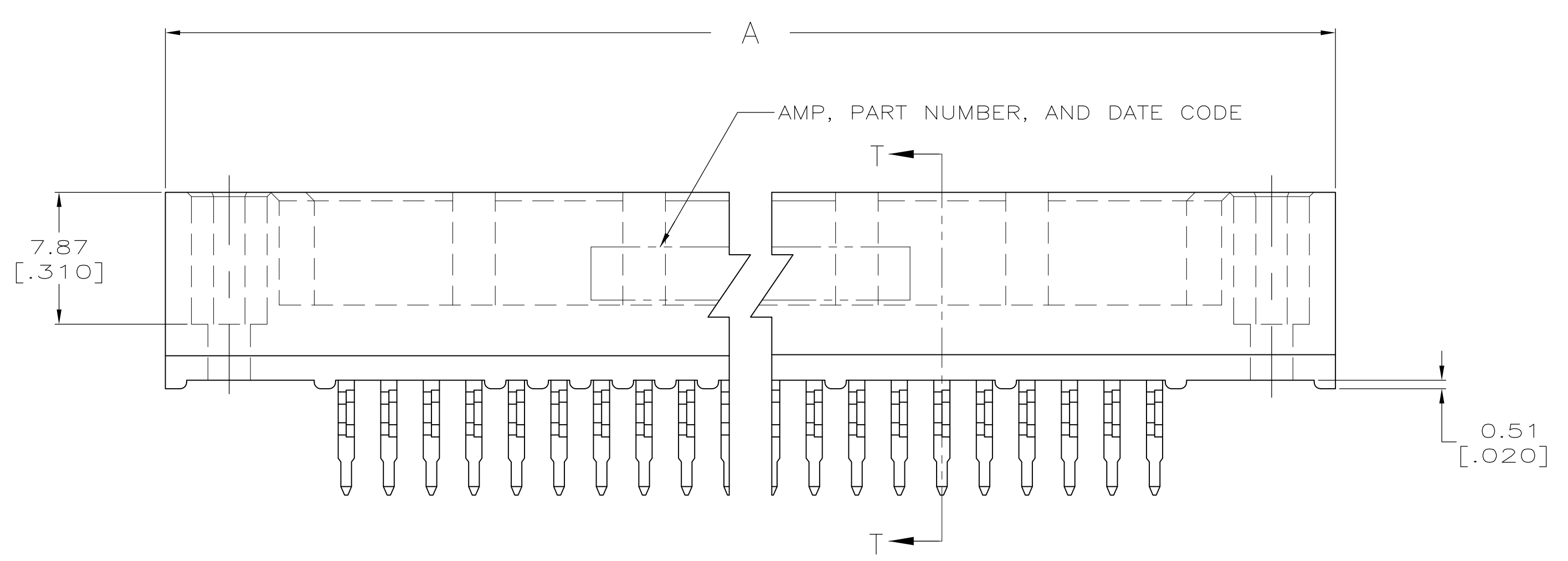
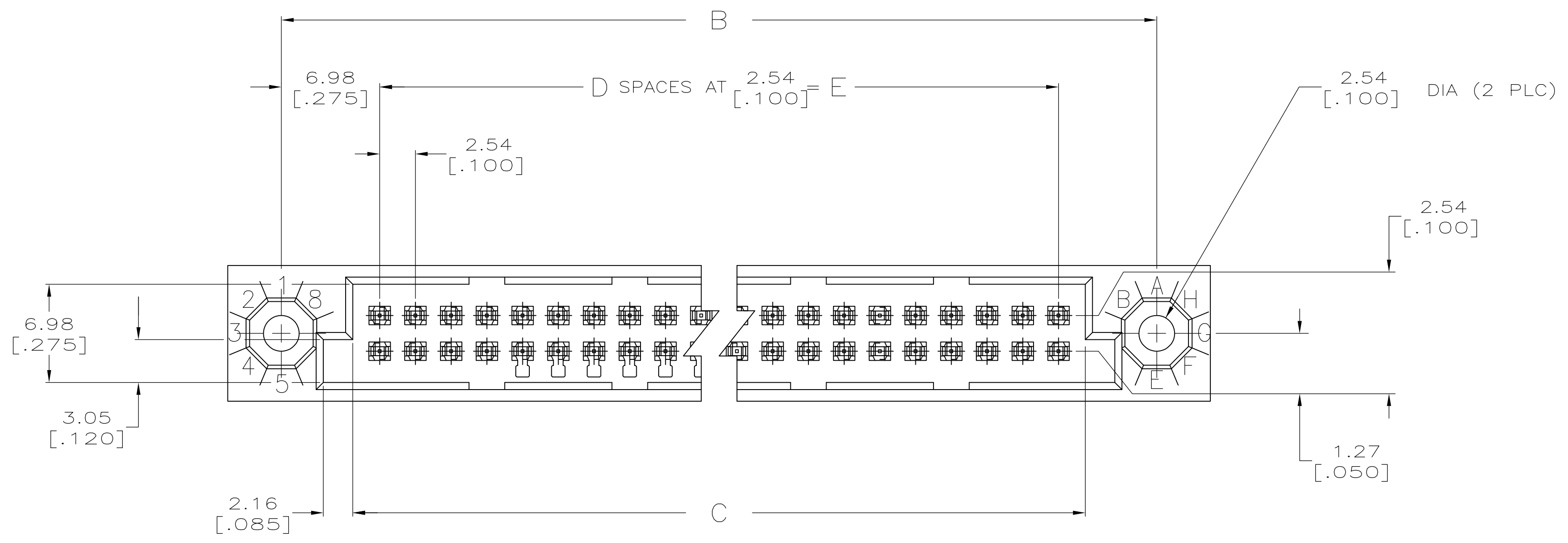

RECOMMENDED P.C. BOARD LAYOUT

THIS DRAWING IS A CONTROLLED DOCUMENT.		DIN R.K. SEIFRIED 03/23/90	TE Connectivity	
		CHK G. SKIPPER 03/23/90		
DIMENSIONS: mm [INCHES]	TOLERANCES UNLESS OTHERWISE SPECIFIED:	APVD	NAME	
	0 PLC ± -	-	PRODUCT SPEC	
	1 PLC ± -		APPLICATION SPEC	
	2 PLC ± -		-	
	3 PLC ± 0.13 [.005]		-	
MATERIAL	FINISH	WEIGHT	SIZE	RESTRICTED TO
		0	A1	
		CUSTOMER DRAWING	SCALE 4:1	SHEET 1 OF 2

REVISIONS				
P	LTR	DESCRIPTION	DATE	APPV
-	-	SEE SHEET 1	-	-

- ① HOUSING MATERIAL: THERMOPLASTIC, COLOR-NATURAL.
- ② CONTACT MATERIAL: PHOSPHOR BRONZE.
- ③ FINISH:
MATING AREA: MEETS THE PERFORMANCE REQUIREMENTS OF PRODUCT SPECIFICATION 108-9063; BASED ON TELCORDIA DR-1217-CORE APPLICATIONS IN UNCONTROLLED ENVIRONMENTS.
SOLDER TAILS AREA: TIN-LEAD PLATED.
- ④ ACTION PIN POSTS REQUIRE 2.36 [.093] MIN THICK P.C. BOARD. RECOMMENDED P.C. BOARD HOLES ARE 1.151 [.0453] DIA PLATED THRU WITH 0.025-0.076 [.001-.003] COPPER, WITH 0.0076 [.0003] MIN TIN-LEAD PLATING; FINISHED HOLE AFTER PLATING 0.94-1.09 [.037-.043] DIA; AFTER RELOW 0.91-1.09 [.036-.043].
- 5. DIMENSIONS IN BRACKETS ARE IN INCHES.
- ⑥ HOUSINGS WITH CENTER MOUNTING IS RECOMMENDED FOR ASSEMBLIES HAVING 75 CONTACTS PER ROW OR MORE.
- ⑦ PART NUMBER IS OBSOLETE.
- ⑧ FINISH:
CONTACT FINISH: .00127-.00254 [.000050-.000100] NICKEL UNDERPLATE ALL OVER; .000762 [.000030] GOLD PLATE IN CONTACT AREA, TIN-LEAD PLATED POSTS.

⑧	60.96 [2.400]	24	64.77 [2.550]	74.93 [2.950]	82.55 [3.250]	50	3-532446-4
⑥⑦	—	—	—	—	—	—	2-532446-0
⑥	251.46 [9.900]	99	255.27 [10.050]	265.43 [10.450]	273.05 [10.750]	200	1-532446-9
⑥⑦	—	—	—	—	—	—	1-532446-8
⑥⑦	—	—	—	—	—	—	1-532446-7
⑥⑦	—	—	—	—	—	—	1-532446-6
⑥⑦	—	—	—	—	—	—	1-532446-5
⑧	187.96 [7.400]	74	191.77 [7.550]	201.93 [7.950]	209.55 [8.250]	150	1-532446-4
⑧	175.26 [6.900]	69	179.07 [7.050]	189.23 [7.450]	196.85 [7.750]	140	1-532446-3
⑧	—	—	—	—	—	—	1-532446-2
⑧	149.86 [5.900]	59	153.67 [6.050]	163.83 [6.450]	171.45 [6.750]	120	1-532446-1
⑧	137.16 [5.400]	54	140.97 [5.550]	151.13 [5.950]	158.75 [6.250]	110	1-532446-0
⑧	124.46 [4.900]	49	128.27 [5.050]	138.43 [5.450]	146.05 [5.750]	100	532446-9
⑧	—	—	—	—	—	—	532446-8
⑧	99.06 [3.900]	39	102.87 [4.050]	113.03 [4.450]	120.65 [4.750]	80	532446-7
⑧	86.36 [3.400]	34	90.17 [3.550]	100.33 [3.950]	107.95 [4.250]	70	532446-6
⑧	73.66 [2.900]	29	77.47 [3.050]	87.63 [3.450]	95.25 [3.750]	60	532446-5
⑧	60.96 [2.400]	24	64.77 [2.550]	74.93 [2.950]	82.55 [3.250]	50	532446-4
⑧	48.26 [1.900]	19	52.07 [2.050]	62.23 [2.450]	69.85 [2.750]	40	532446-3
⑧	35.56 [1.400]	14	39.37 [1.550]	49.53 [1.950]	57.15 [2.250]	30	532446-2
⑧	22.86 [.900]	9	26.67 [1.050]	36.83 [1.450]	44.45 [1.750]	20	532446-1
	E	D	C	B	A	POSN	PART NUMBER

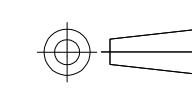
THIS DRAWING IS A CONTROLLED DOCUMENT.		DIN R.K. SEIFRIED 03/23/90 CHK G. SKIPPER 03/23/90		APVD		NAME	
DIMENSIONS: mm [INCHES]		TOLERANCES UNLESS OTHERWISE SPECIFIED:		PRODUCT SPEC		APPLICATION SPEC	
		0 PLC ± - 1 PLC ± - 2 PLC ± - 3 PLC ± 0.13 [.005] 4 PLC ± - ANGLES ± -		SIZE		CAGE CODE DRAWING NO	
MATERIAL		FINISH		WEIGHT		A1 00779 532446	
CUSTOMER DRAWING				SCALE 4:1		SHEET 2 OF 2 REV W	