

REVISIONS					
REV	ECO	DESCRIPTION	DATE	BY	APPR
A1	--	RELEASED DRAWING	Jun-15-18	White	TOMMY
A2	--	UPDATE NOTES	Oct-18-2018	Blink	Tommy

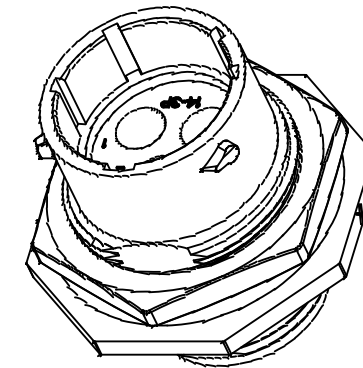
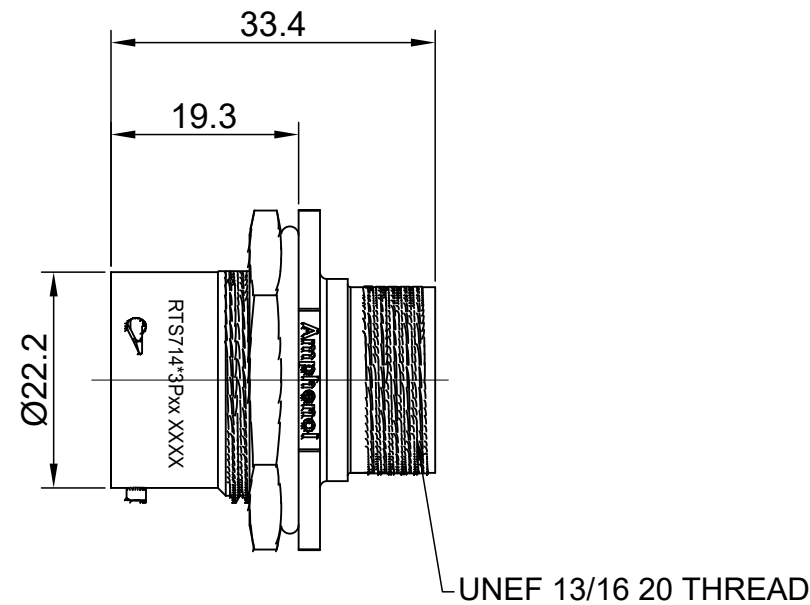
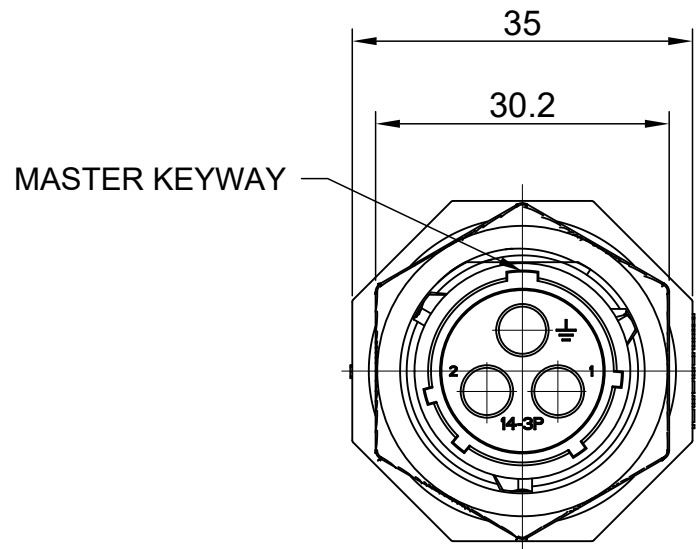

NOTES: (UNLESS OTHERWISE SPECIFIED)

1. MATERIAL:

- SHELL: THERMOPLASTIC, UL94 V-0.
- INSERT: THERMOPLASTIC, UL94 V-0.
- O-RING: NBR OR SILICONE RUBBER.
- SEAL GASKET: NBR OR SILICONE RUBBER.
- JAM NUT: ALUMINIUM ALLOY, BLACK ANODIZING.

2. SPECIFICATIONS:

- 2.1 RATED CURRENT: 45A (MAX).
- 2.2 RATED VOLTAGE: 600V(AC/DC).
- 2.3 OPERATING TEMPERATURE: SEE TABLE.
- 2.4 DIELECTRIC WITHSTANDING VOLTAGE: LESS THAN 2 MILLIAMPS CURRENT LEAKAGE@2500 VOLTS AC.
- 2.5 INSULATION RESISTANCE: 5000 MEGOHMS MIN.
- 2.6 IP CLASS: IP67 AND IP69K IN THE MATED CONDITION, WIRE SEALS FULLY POPULATED.
- 2.7 MATING CYCLES DURABILITY: 500 CYCLES MIN.
- 2.8 RoHS COMPLIANT.

3. SUITABLE CONTACTS : 8# CONTACT.

A2	CONTACT SIZE	CONTACT PN	WIRE RANGE	CORD GRIP
8#		MP10A23x-25	16 - 14AWG	BACK SHELL
		MP10A23x-63	12 - 10AWG	
		MP10A23x-10	8 AWG	
		MP10A23xL	12 - 10AWG	END CAP

IN THE CONTACT PN, "x" DENOTE DIFFERENT PLATING.

4. ALL DIMENSIONS ARE FOR REFERENCE USE ONLY.

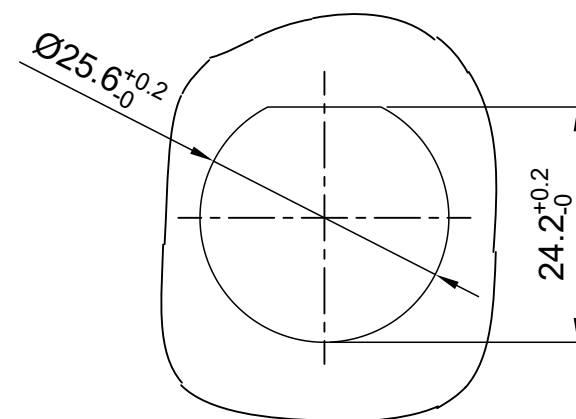

PANEL CUTOUT REFERENCE THICKNESS:3.2MM (MAX)

KEY	PART NUMBER	
		-40°C ~ 105°C
N	RTS714N3P	RTS714N3P03

TITLE: ECO-MATE RECEPTACLE, JAM NUT, SIZE 14,3POS,PIN  
 DWG NO: RTS714\*3Pxx  
 REV: A2  
 SH: 1  
 OF: 1

QUANTITY	PART NUMBER	DESCRIPTION	ITEM
<b>MATERIALS LIST</b>			
UNLESS OTHERWISE SPECIFIED 1) All dimensions are in metric(mm). 2) Tolerances are as follows: 1 PL DEC ±0.30 2 PL DEC ±0.15 3 PL DEC ±0.08 Fractions ±1/64 Angles ±1° 3) Note reference =		<b>Amphenol</b> Sine Systems - www.amphenol-sine.com 44724 Morley Drive Clinton Township, MI 48036	
SIGNATURES DRAWN: Blink CHECKED: Tod ENGINEER: APPROVAL: Tommy DATE: Oct-18-2018 DATE: Oct-18-2018		ECO-MATE, RECEPTACLE, JAM NUT, SIZE 14,3POS,PIN	
MATERIAL SPECIFICATIONS:		CUSTOMER:	
PROCESS SPECIFICATIONS:		THIS DRAWING IS SUPPLIED FOR INFORMATION ONLY. DESIGN FEATURES, SPECIFICATIONS AND PERFORMANCE DATA SHOWN HEREON ARE THE PROPERTY OF THE AMPHENOL CORPORATION. NO RIGHTS OF REPRODUCTION ARE IMPLIED. ALL DIMENSIONS ARE SUBJECT TO NORMAL MANUFACTURING VARIATIONS.	
NEXT ASSY:		SIZE: B TYPE: C- SCALE: NONE	DWG NO: RTS714*3Pxx REVISION: A2 SHEET 1 OF 1

**ecomate® RM/RSSM/Aquarius™ - Contact Size 3.6mm (1403 Insert Arrangement) Options**

Crimp Contacts, 1403 Insert Arrangement, Machined					
Part Number		AWG	Wire Range (mm <sup>2</sup> )	For Use w Endcap	Plating
Male	Female				
MP10A23T-10	MS10A23T-10	8	10.0	No	Tin
MP10A23S-10	MS10A23S-10	8	10.0	No	Silver
MP10A23F-10	MS10A23F-10	8	10.0	No	Gold Flash
MP10A23G5-10	MS10A23G5-10	8	10.0	No	Gold 5μ"
MP10A23G10-10	MS10A23G10-10	8	10.0	No	Gold 10μ"
MP10A23G15-10	MS10A23G15-10	8	10.0	No	Gold 15μ"
MP10A23G30-10	MS10A23G30-10	8	10.0	No	Gold 30μ"
MP10A23S-63	MS10A23S-63	12-10	4.0 - 6.0	No	Silver
MP10A23F-63	MS10A23F-63	12-10	4.0 - 6.0	No	Gold Flash
MP10A23TL	MS10A23T	12-10	3.0 - 6.0	Yes	Tin
MP10A23SL	MS10A23S	12-10	3.0 - 6.0	Yes	Silver
MP10A23FL	MS10A23F	12-10	3.0 - 6.0	Yes	Gold Flash
MP10A23G5L	MS10A23G5	12-10	3.0 - 6.0	Yes	Gold 5μ"
MP10A23G10L	MS10A23G10	12-10	3.0 - 6.0	Yes	Gold 10μ"
MP10A23G15L	MS10A23G15	12-10	3.0 - 6.0	Yes	Gold 15μ"
MP10A23G30L	MS10A23G30	12-10	3.0 - 6.0	Yes	Gold 30μ"
MP10A23S-25	MS10A23S-25	16-14	1.5 - 2.5	No	Silver
MP10A23F-25	MS10A23F-25	16-14	1.5 - 2.5	No	Gold Flash

Tooling, Machined	
Part Number	Description
QXRT08	Contact Extraction Tool, # 8 (Ø 3.6mm) Contact
M300BT	Hand Crimper
WA27-300BT-EP	Pneumatic Crimper
TP968	Locator M3200BT and WA27-300BT-EP

Plating Options	
Symbol	Plating
T	Tin Plating Over Nickel
S	Silver Plating Over Nickel
F	Gold Plated
G5	Gold Plated (Thickness 5μ")
G10	Gold Plated (Thickness 10μ")
G15	Gold Plated (Thickness 15μ")
G30	Gold Plated (Thickness 30μ")