

Housing - HC-STA-D07-BWS-PL-BK - 1419265

Please be informed that the data shown in this PDF Document is generated from our Online Catalog. Please find the complete data in the user's documentation. Our General Terms of Use for Downloads are valid (<http://phoenixcontact.com/download>)



Panel mounting base D7, with single locking latch, material: PA, height: 25.5 mm, cable gland: none, support sleeve: no, Standard



Key Commercial Data

Packing unit	1 pc
GTIN	
GTIN	4055626160160

Technical data

Dimensions

Height	25.5 mm
Width	34.2 mm
Length	24.2 mm
Length of the assembly cutout	21 mm
Width of the assembly cutout	21 mm

Ambient conditions

Degree of protection (IP)	IP66
Ambient temperature (operation)	-40 °C ... 125 °C

General

Note	for contact inserts HC-A03, A04, D07, D08, Q02, Q03, Q04, Q05, Q07, Q12
Size	D7
Housing type	Panel mounting base
Color	black
Locking type	with single locking latch
Screw connection	none
Housing material	PA

Housing - HC-STA-D07-BWS-PL-BK - 1419265

Technical data

General

Seal material	NBR
Material lock	PA
Flammability rating according to UL 94	V0 (Polyamide housing)

Environmental Product Compliance

China RoHS	Environmentally Friendly Use Period = 50
	For details about hazardous substances go to tab "Downloads", Category "Manufacturer's declaration"

Drawings

Dimensional drawing

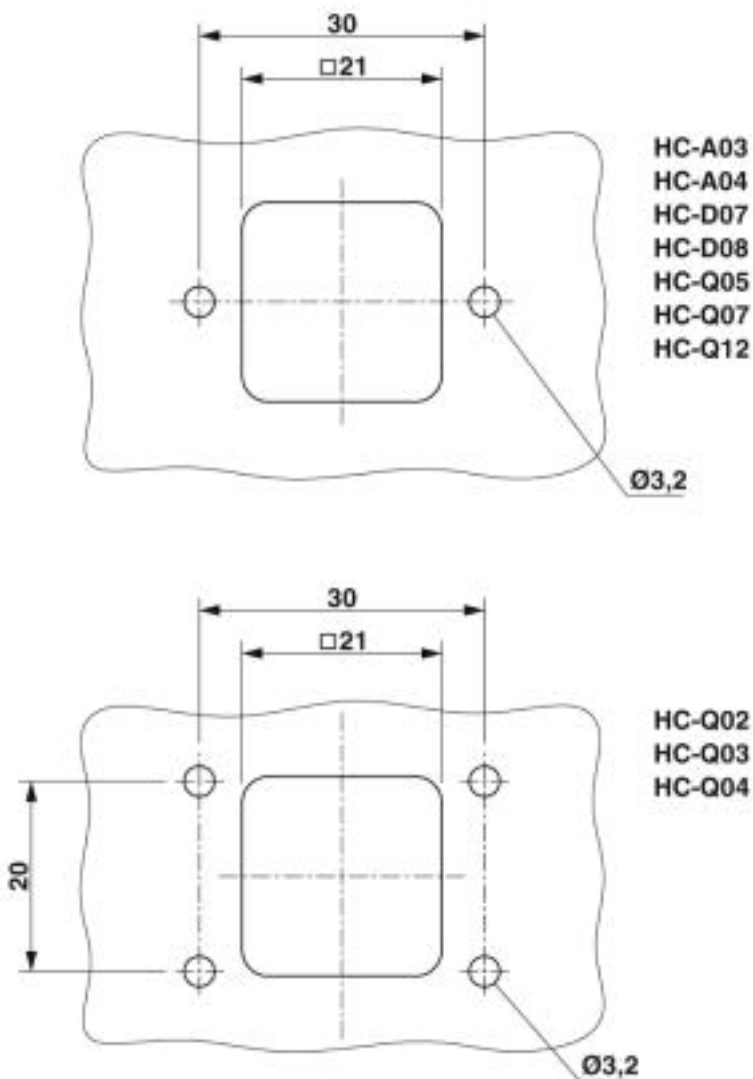

Mounting cutout

Housing - HC-STA-D07-BWS-PL-BK - 1419265

Dimensional drawing

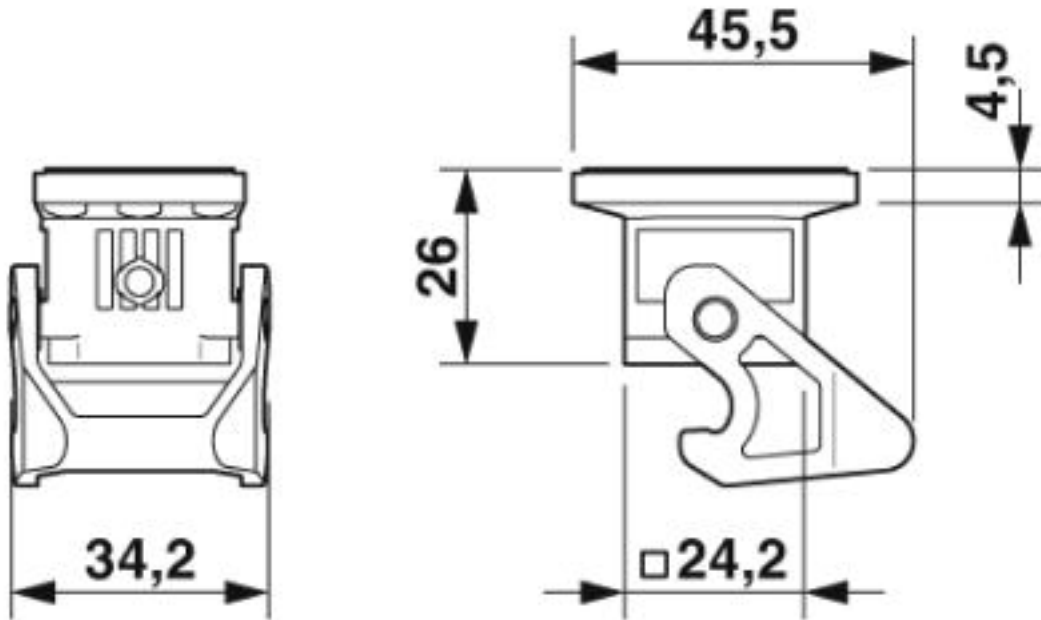

Dimensional drawing

Approvals

Approvals

Approvals

EAC / DNV GL

Ex Approvals

Approval details

EAC		RU C- DE.AI30.B.01102
-----	--	--------------------------

DNV GL		https://approvalfinder.dnvgl.com/	TAE000037S
--------	--	---	------------

Phoenix Contact 2019 © - all rights reserved
<http://www.phoenixcontact.com>

PHOENIX CONTACT GmbH & Co. KG
Flachmarktstr. 8
32825 Blomberg
Germany
Tel. +49 5235 300
Fax +49 5235 3 41200
<http://www.phoenixcontact.com>