

# Development Board EPC9093 Quick Start Guide

*100 V Half-bridge with Gate Drive, Using EPC2053*

Revision 1.0



## DESCRIPTION

The EPC9093 development board is a 100 V maximum device voltage, 20 A maximum output current, half bridge with onboard gate drives, featuring the EPC2053 enhancement mode (eGaN®) field effect transistor (FET). The purpose of this development board is to simplify the evaluation process of the EPC2053 eGaN FET by including all the critical components on a single board that can be easily connected into any existing converter.

The EPC9093 development board is 2" x 2" and contains two EPC2053 eGaN FETs in a half bridge configuration using the upi Semiconductor up1966A gate driver. The board also contains all critical components and layout for optimal switching performance. There are also various probe points to facilitate simple waveform measurement and efficiency calculation. A block diagram of the circuit is given in figure 1.

For more information on the EPC2053 please refer to the datasheet available from EPC at [www.epc-co.com](http://www.epc-co.com). The datasheet should be read in conjunction with this quick start guide.

## QUICK START PROCEDURE

Development board EPC9093 is easy to set up to evaluate the performance of two EPC2053 eGaN FETs. Refer to figure 2 for proper connect and measurement setup and follow the procedure below:

1. With power off, connect the input power supply bus to +V<sub>IN</sub> (J5, J6) and ground / return to -V<sub>IN</sub> (J7, J8).
2. With power off, connect the switch node (SW) of the half bridge OUT (J3, J4) to your circuit as required (half bridge configuration). The EPC9093 features an optional buck converter configuration, as shown in figure 2, with unpopulated footprints for an output inductor and output capacitors.
3. With power off, connect the gate drive supply to +V<sub>DD</sub> (J1, Pin-1) and ground return to -V<sub>DD</sub> (J1, Pin-2 indicated on the bottom side of the board).
4. With power off, connect the input PWM control signal to PWM (J2, Pin-1) and ground return to any of the ground J2 pins, while observing the switch-node voltage and device temperature for operational limits.
5. Turn on the gate drive supply – make sure the supply is between 7.5 V and 12 V range.
6. Turn on the controller / PWM input source.
7. Making sure the supply voltage initially is 0 V, turn on the power and slowly increase the bus voltage to the required value, while observing the switch-node voltage and device temperature for operational limits, (do not exceed the absolute maximum voltage) and probe switching node to see switching operation.
8. Once operational, adjust the PWM control, bus voltage, and load within the operating range and observe the output switching behavior, efficiency and other parameters.
9. For shutdown, please follow steps in reverse.

**Table 1: Performance Summary (T<sub>A</sub> = 25°C) EPC9093**

Symbol	Parameter	Conditions	Min	Max	Units
V <sub>DD</sub>	Gate Drive Input Supply Range		7.5	12	V
V <sub>IN</sub>	Bus Input Voltage Range <sup>(1)</sup>			80	V
I <sub>OUT</sub>	Switch Node Output Current <sup>(2)</sup>			20	A
V <sub>PWM</sub>	PWM Logic Input Voltage Threshold	Input 'High' / 'Low'	3.5 / 0	5.5 / 1.5	V / V
	Minimum 'High' State Input Pulse Width	V <sub>PWM</sub> rise and fall time < 10ns	50		ns
	Minimum 'Low' State Input Pulse Width <sup>(3)</sup>	V <sub>PWM</sub> rise and fall time < 10ns	200		ns

(1) Maximum input voltage depends on inductive loading, maximum switch node ringing must be kept under 100 V for EPC2053.

(2) Maximum current depends on die temperature – actual maximum current will be subject to switching frequency, bus voltage and thermal cooling.

(3) Limited by time needed to 'refresh' high side bootstrap supply voltage.

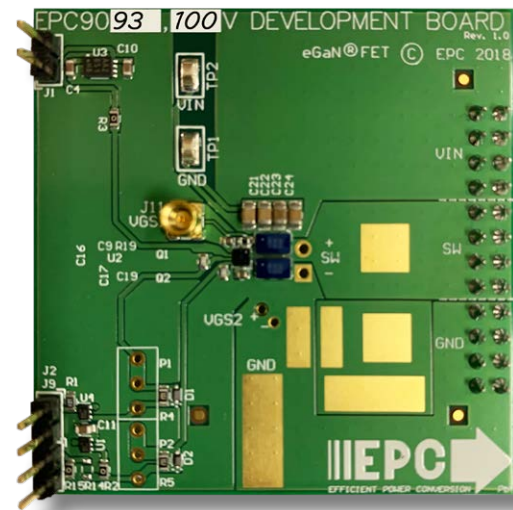

EPC9093 development board

**NOTE.** When measuring the high frequency content switch node, care must be taken to provide an accurate high speed measurement. An optional two pin header (J10) is included for switch node measurement. It is recommended to install measurement point on backside of board to prevent contamination of the top side components.

For information about measurement techniques, please review the how to GaN series: HTG09- Measurement

<http://epc-co.com/epc/DesignSupport/TrainingVideos/HowtoGaN/>

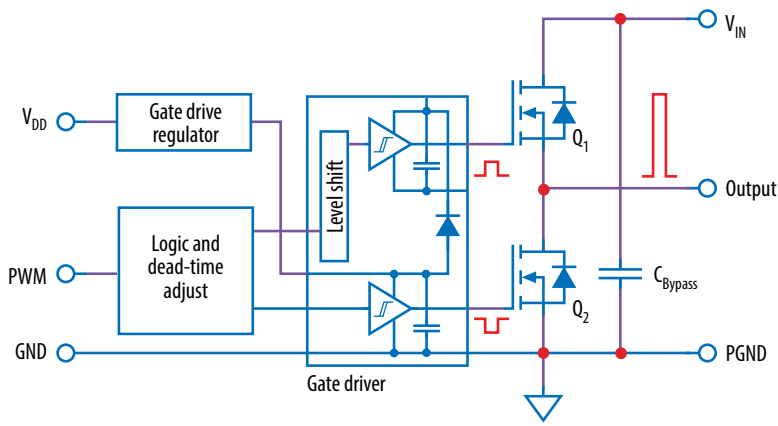

Figure 1: Block diagram of EPC9093 development board

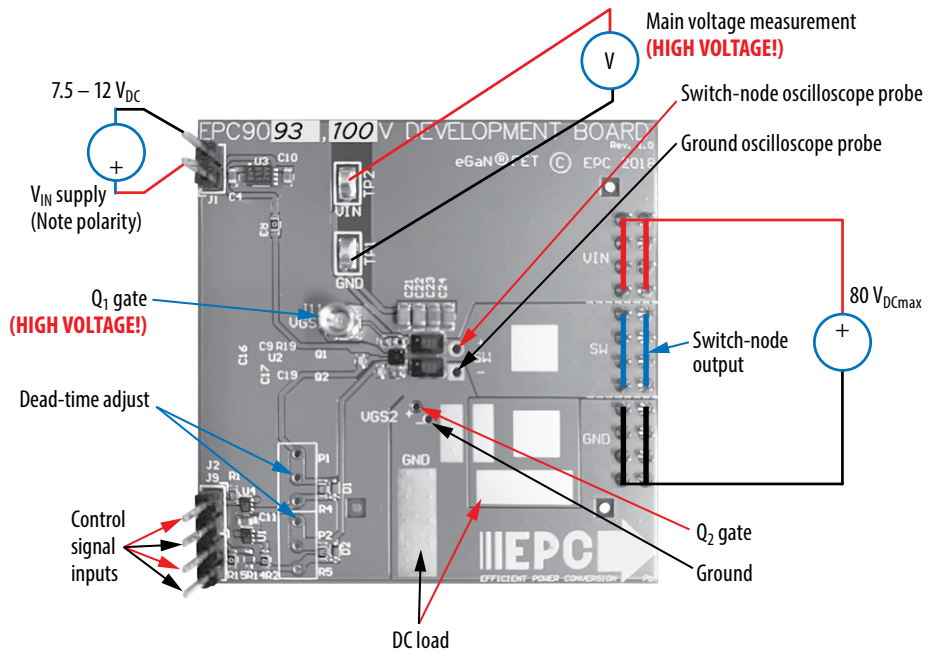

Figure 2: Proper connection and measurement setup

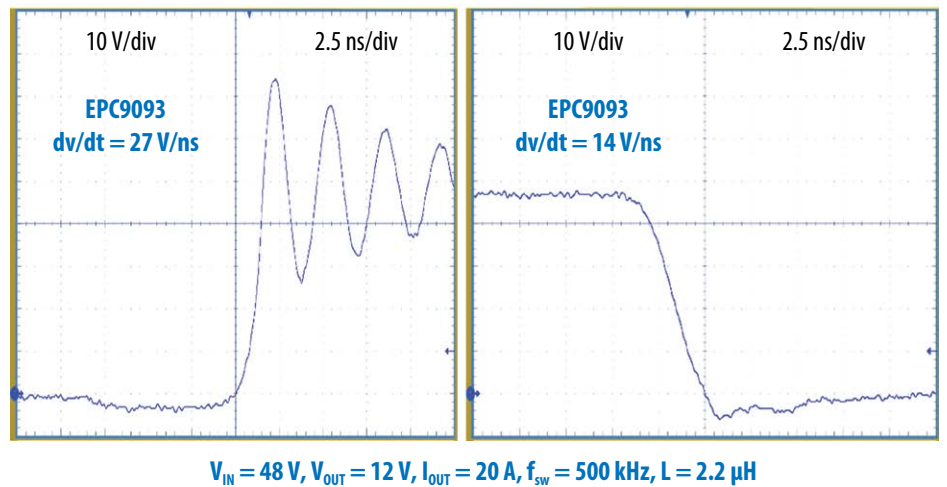

Figure 3: Typical Waveform when operating as a Buck Converter

## THERMAL CONSIDERATIONS

The EPC9093 development board showcases the EPC2053 eGaN FET. The EPC9093 is intended for bench evaluation with low ambient temperature and convection cooling. The addition of heat-sinking and forced air cooling can significantly increase the current rating of these devices, but care must be taken to not exceed the absolute maximum die temperature of 150° C.

**NOTE.** The EPC9093 development board does not have any current or thermal protection on board.

For more information regarding the thermal performance of EPC eGaN FETs, please consult:

D. Reusch and J. Glaser, *DC-DC Converter Handbook*, a supplement to *GaN Transistors for Efficient Power Conversion*, First Edition, Power Conversion Publications, 2015.

**Table 2: Bill of Materials**

Item	Qty	Reference	Part Description	Manufacturer	Part Number
1	3	C4, C10, C11	Capacitor, 1 µF, 10%, 25 V, X5R	Murata	GRM188R61E105KA12D
2	1	C9	Capacitor, 0.1 µF, 10%, 25 V, X5R	TDK	C1005X5R1E104K050BC
3	2	C16, C17	Capacitor, 100 pF, 5%, 50 V, NP0	Kemet	C0402C101K5GACTU
4	1	C19	Capacitor, 1 µF, 10%, 25 V, X5R	TDK	C1005X5R1E105K050BC
5	4	C21, C22, C23, C24	Capacitor, CER 1 µF 100 V 20% X7S 0805	TDK	C2012X7S2A105M125AB
6	2	D1, D2	Schottky Diode, 30 V	Diodes Inc.	SDM03U40-7
7	2	Q1, Q2	eGaN FET, 100 V, 3.5 mΩ	EPC	EPC2053
8	1	U1	IC GATE NAND 1CH 2-INP 6MICROPAK	Fairchild	NC7SZ00L6X
9	1	U2	Gate Driver	uPI	up1966A
10	1	U3	Microchip, MCP1703T-5002E/MC	Microchip	MCP1703T-5002E/MC
11	1	U4	IC GATE AND 1CH 2-INP 6-MICROPAK	Fairchild	NC7SZ08L6X
12	1	R1	Resistor, 10.0 k, 5%, 1/8 W	Stackpole	RMCF0603FT10K0
13	3	R2, R15, R3	Resistor, 0 Ω, 1/8 W, 0603	Panasonic	ERJ-3GEY0R00V
14	1	R4	RES SMD 115 Ω 1% 1/10 W 0603	Stackpole	RMCF0603FT160R
15	1	R5	RES SMD 160 Ω 1% 1/10 W 0603	Stackpole	RMCF0603FT160R
16	1	R19	RES SMD 0.0 Ω JUMPER 1/16 W	Stackpole	RMCF0402ZT0R00TR-ND
17	3	J1, J2, J9	2 pins of Tyco, 4-103185-0	Tyco	4-103185-0
18	6	J3, J4, J5, J6, J7, J8	4 pin, male 100 mil header	FCI	68602-224HLF
19	1	J11	MMCX Jack, SMD, 50 Ω	Molex	0734152063
20	2	TP1, TP2	Keystone Elect, 5015	Keystone	5015

### Optional Components

Item	Qty	Reference	Part Description	Manufacturer/Part Number
1	DNP	P1,P2	Optional Potentiometer	1k Bourne P/N PV37W102C01B00, or RJR26FW102M
3	DNP	J12	VGS1 Probe	2 pin 100 mil male header
4	DNP	J10	VSW probe	2 pin 100 mil male header
5	DNP	R14	Resistor, 0 Ω, 1/8 W, 0603	Panasonic, ERJ-3GEY0R00V

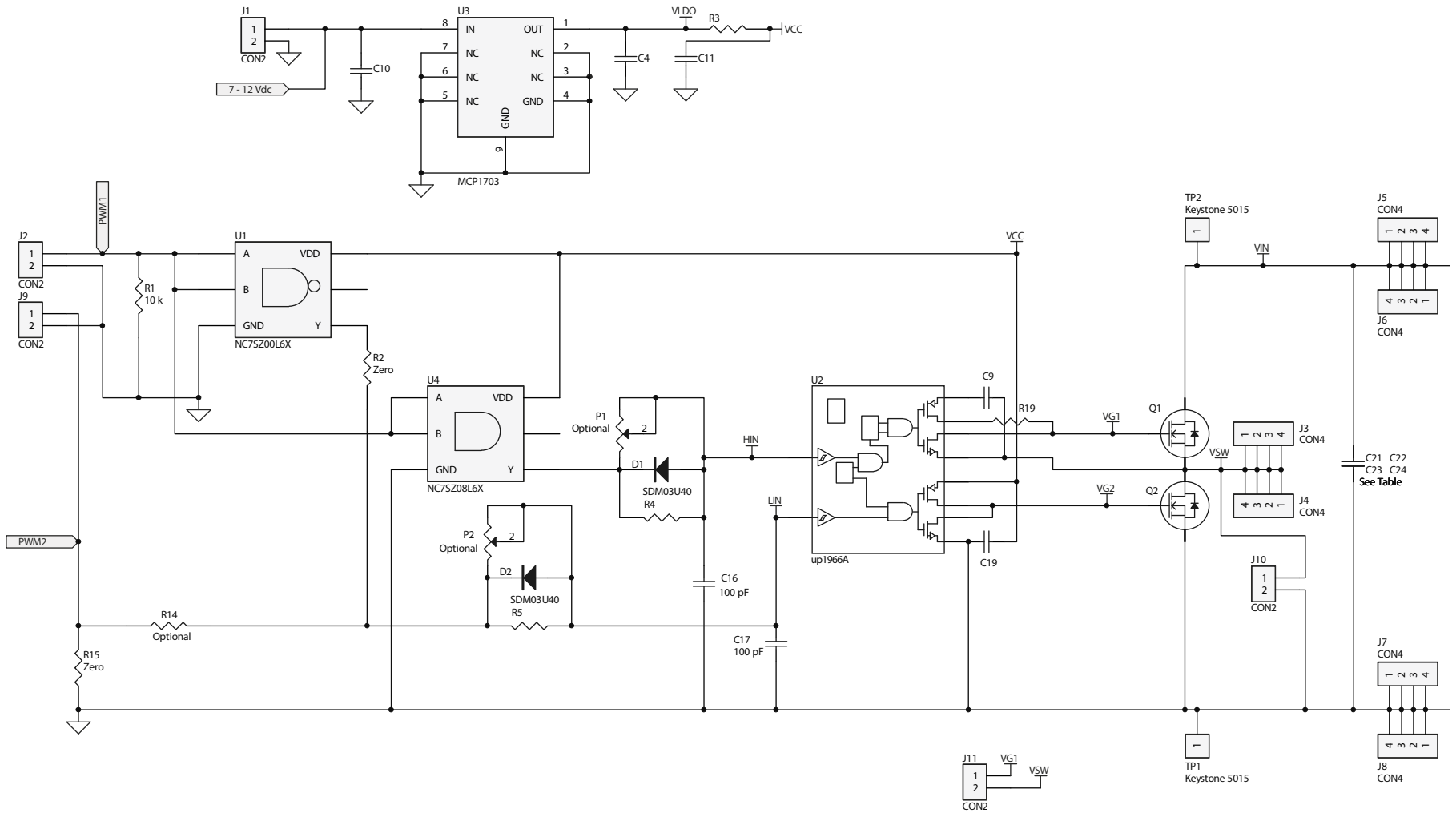

Figure 4: EPC9093 - Schematic

## For More Information:

Please contact [info@epc-co.com](mailto:info@epc-co.com)  
or your local sales representative

Visit our website:  
[www.epc-co.com](http://www.epc-co.com)

Sign-up to receive  
EPC updates at  
[bit.ly/EPCupdates](http://bit.ly/EPCupdates)  
or text "EPC" to 22828



EPC Products are distributed through Digi-Key.  
[www.digikey.com](http://www.digikey.com)

### Demonstration Board Notification

The EPC9093 board is intended for product evaluation purposes only and is not intended for commercial use. Replace components on the Evaluation Board only with those parts shown on the parts list (or Bill of Materials) in the Quick Start Guide. Contact an authorized EPC representative with any questions.

This board is intended to be used by certified professionals, in a lab environment, following proper safety procedures. Use at your own risk.

As an evaluation tool, this board is not designed for compliance with the European Union directive on electromagnetic compatibility or any other such directives or regulations. As board builds are at times subject to product availability, it is possible that boards may contain components or assembly materials that are not RoHS compliant. Efficient Power Conversion Corporation (EPC) makes no guarantee that the purchased board is 100% RoHS compliant.

The Evaluation board (or kit) is for demonstration purposes only and neither the Board nor this Quick Start Guide constitute a sales contract or create any kind of warranty, whether express or implied, as to the applications or products involved.

Disclaimer: EPC reserves the right at any time, without notice, to make changes to any products described herein to improve reliability, function, or design. EPC does not assume any liability arising out of the application or use of any product or circuit described herein; neither does it convey any license under its patent rights, or other intellectual property whatsoever, nor the rights of others.