

MOUNTING PAD LAYOUT. REQUIRED SPACING FOR 'A' OR 'AA' BATTERIES

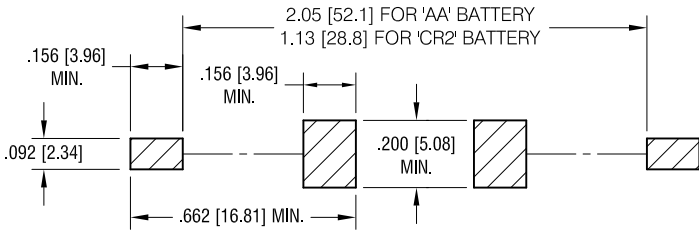

THIS DOCUMENT IS THE PROPERTY OF KEYSTONE ELECTRONICS CORP. AND SHALL NOT BE REPRODUCED, DISTRIBUTED OR USED AS A BASIS FOR MANUFACTURE WITHOUT PRIOR WRITTEN PERMISSION FROM KEYSTONE ELECTRONICS CORP.

ACTUAL SIZE

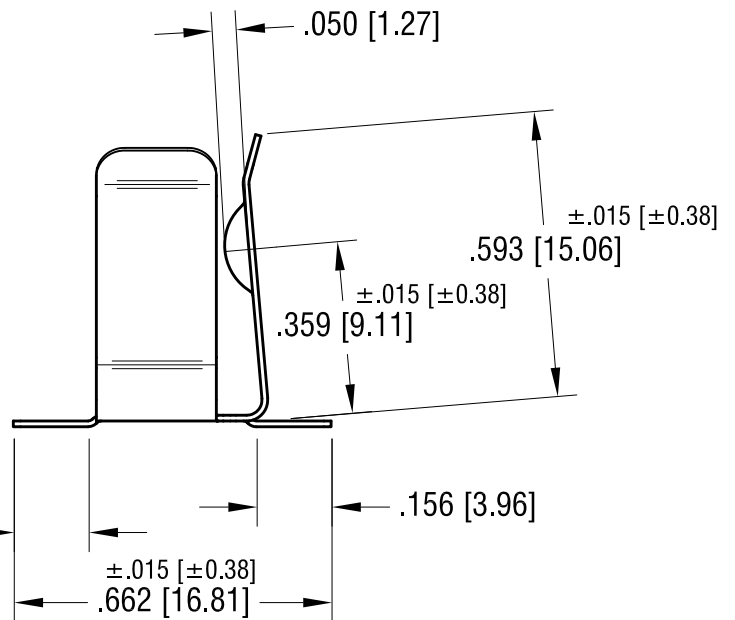
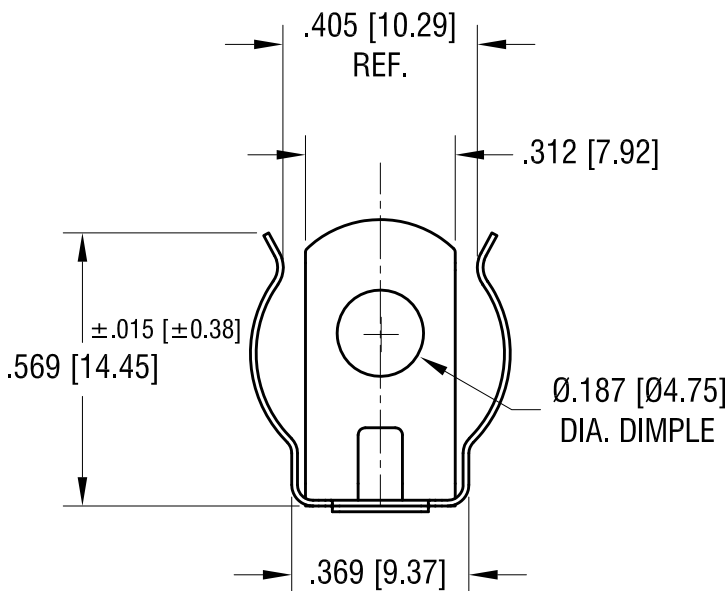
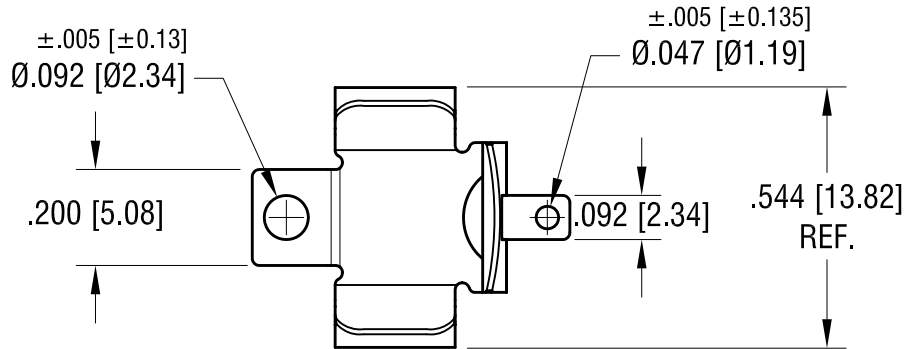

NOTE:

1. HEAT TREAT TO SPRING TEMPER.

KEYSTONE ELECTRONICS CORP.

www.keyelco.com • NEW HYDE PARK, NY 11040 • Tel (516) 328-7500

PART NAME

'CR2' & 'AA' BATTERY CLIP

MATERIAL

.012 [0.30] TH'K ANNEALED SPRING STEEL

FINISH

MATTE TIN PLATE

DRN BY

NT

DATE

7.20.09

APP'D

RH

SCALE

2.5X

TOLERANCES INCH [MM]

DECIMAL ±.010 [±0.25]

CODE

C

ANGULAR ± 1° UNLESS OTHERWISE SPECIFIED

DWG NO.

553

1.31.18	CHANGE AS PER ECN 18-008	B
10.20.09	CHANGE AS PER ECN 09-153	A
DATE	DESCRIPTION	REV.