

Tous droits strictement réservés. Reproduction ou communication o des liens interdite sous quelque forme que ce soit sans autorisation écrite du propriétaire. Propriété de c FCI. Droits de reproduction FCI.

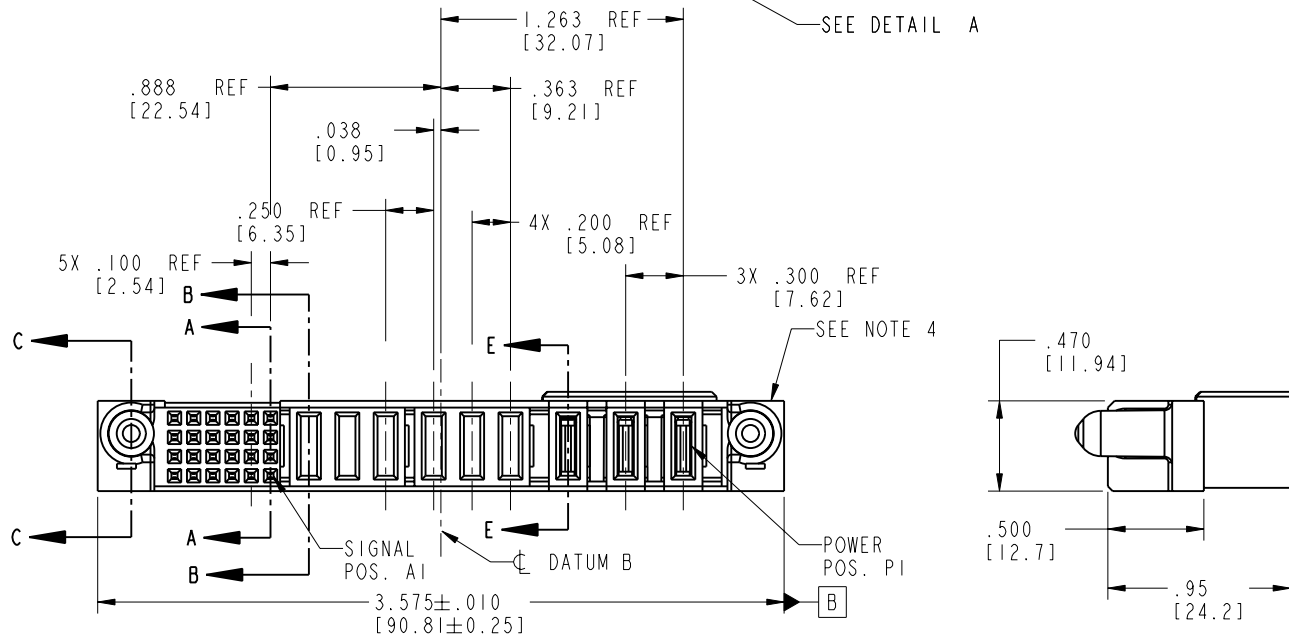

All rights strictly reserved. Reproduction or issue to third parties in any form whenever is not permitted without written authority from the proprietor. Property of FCI. Copyright FCI.

PRODUCT NO.	ROWS	SIGNAL						POWER								E1	
		E2	6	5	4	3	2	1	P9	P8	P7	P6	P5	P4	P3		P2
51929-003-- NOTE: ③	D C B A		F	F	F	F	F	PF	PF	PF	PF	PF	PF	PG	PH	PH	

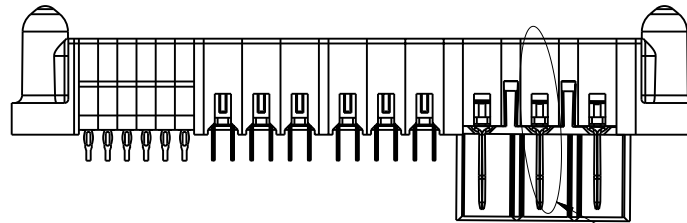

CODE	DIM "M" MATING LENGTH	CONTACT TYPE
F	N/A [N/A]	SIGNAL
PF	.092 [2.34]	POWER
PG	.042 [1.07]	POWER
PH	.092 [2.34]	POWER

mat'l code		SEE NOTE 2		tolerances unless otherwise specified		CUSTOMER		FCI	
ltr	ecn no.	dr	date	linear	.XX ± .01/0.X ± 0.3	COPY		www.fciconnect.com	
A	DG06-0024	CS	01/16/06	angles	.XXX ± .005/0.XX ± 0.13	projection		title 3ACP + 6P + 24S	
					.XXX ± .0020/0.XX ± 0.051	INCH/MM		VERTICAL PRESS-FIT RECEPT	
				dr	CS 01/16/06	scale		product family PwrBlade code 213	
				engr	STEVEN WANG 01/16/06	1:1		size dwg no	
				chr	BEER FU 01/16/06			A 51929-003	
				appd	JOESPH HSIA 01/16/06			sheet 1 of 4	
sheet index	revision sheet	A	A	A	A			coge code 22526	
1	2	3	4					4	

Pro/E

PDM: Rev:A

STATUS: Released

Printed: Dec 20, 2010

Tous droits strictement réservés. Reproduction ou communication o des liers interdite sous quelque forme que ce soit sans autorisation écrite du propriétaire. Propriété de c FCI. Droits de reproduction FCI.



All rights strictly reserved. Reproduction or issue to third parties in any form, whatever is not permitted without written authority from the proprietor. Property of FCI. Copyright FCI.

PRODUCT NUMBER

51929-003__
NOTE: ③

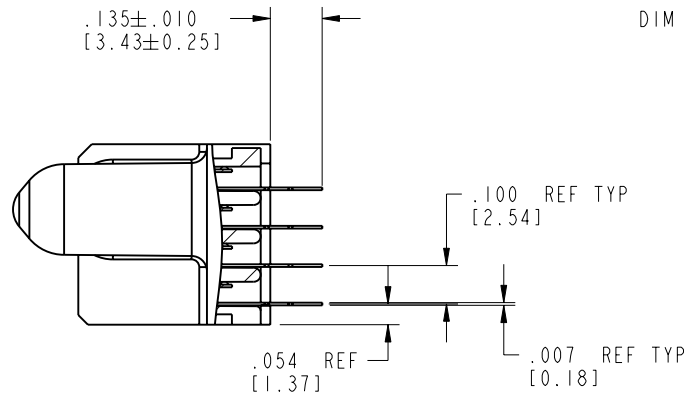

SECTION A-A
SCALE 2:1

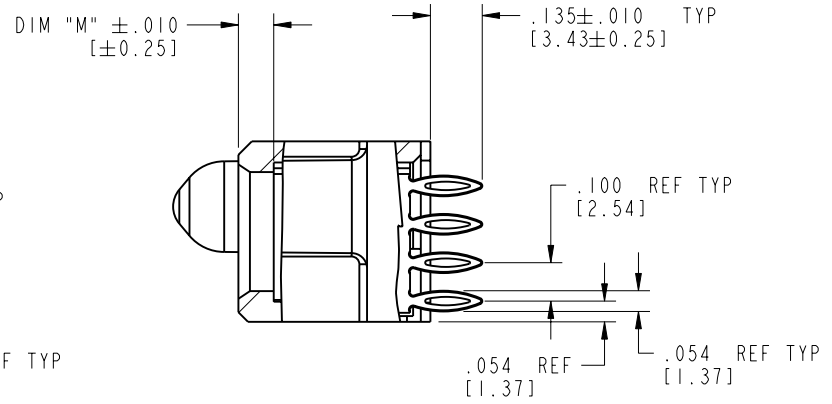

SECTION B-B
SCALE 2:1

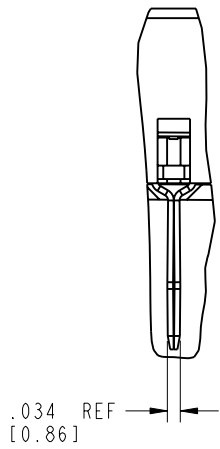

DETAIL A
SCALE 2:1

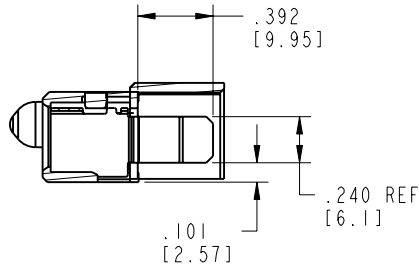

SECTION E-E

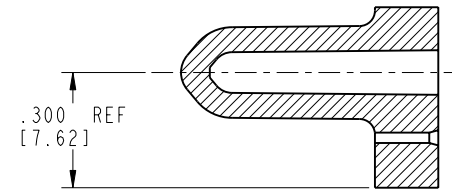

SECTION C-C
SCALE 2:1

mat'l code		SEE NOTE 2		tolerances unless otherwise specified		CUSTOMER		FCI	
ltr	ecn no.	dr	date	linear	.XX±.01/0.X±0.3	projection	COPY	www.fciconnect.com	
A				angles	.XXX±.005/0.XXX±0.13			title 3ACP + 6P + 24S	
				dr	.XXX±.0020/0.XXX±0.051			VERTICAL PRESS-FIT RECEPT	
				enr	CS 01/16/06	INCH/MM	product family	PwrBlade	code 213
				chr	STEVEN WANG 01/16/06	scale	size	dwg no	sheet
				appd	BEER FU 01/16/06	1:1	A	51929-003	2 of 4
					JOESPH HSIA 01/16/06				
sheet index	revision sheet								

Pro/E

cage code 22526

PDM: Rev:A

STATUS: Released

Printed: Dec 20, 2010

Tous droits strictement réservés. Reproduction ou communication o des liers interdité sous quelque forme que ce soit sans autorisation écrite du propriétaire. Propriété de c FCI. Droits de reproduction FCI.



All rights strictly reserved. Reproduction or issue to third parties in any form, whenever is not permitted without written authority from the proprietor. Property of FCI. Copyright FCI.

PRODUCT NUMBER

51929-003__
NOTE: ③

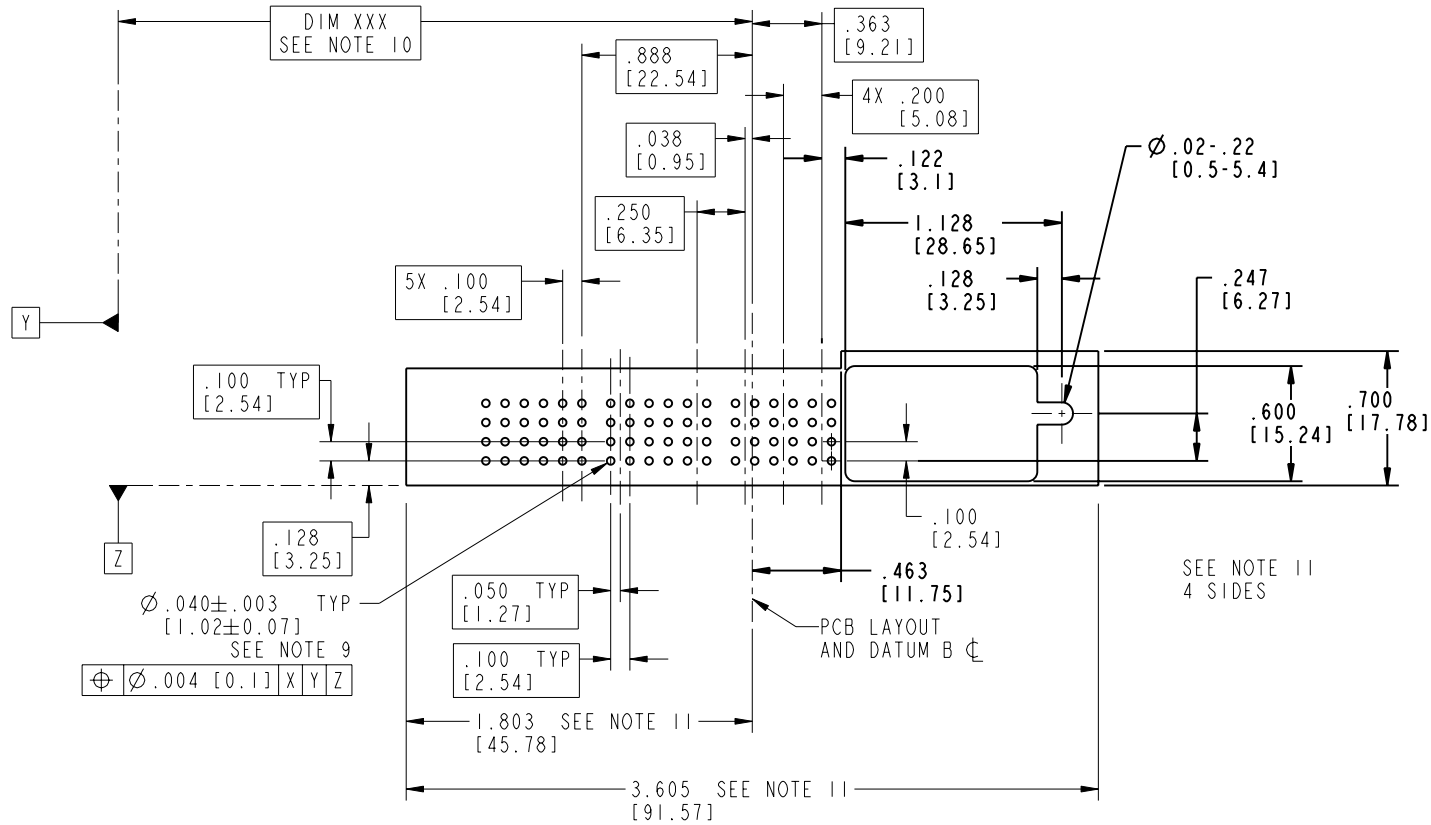

mat'l code		SEE NOTE 2		tolerances unless otherwise specified		CUSTOMER		FCI	
ltr	ecn no.	dr	date	linear	.XX ± .01 / 0.X ± 0.3	projection	COPY	www.fciconnect.com	
A				angles	.XXX ± .005 / 0.XX ± 0.13			title 3ACP + 6P + 24S	
				dr	.XXX ± .0020 / 0.XXX ± 0.051		INCH/MM	VERTICAL PRESS-FIT RECEPT	
				enr	CS 01/16/06	scale	1:1	product family	PwrBlade
				chr	STEVEN WANG 01/16/06			code	213
				appd	BEER FU 01/16/06			size	A
					JOESPH HSIA 01/16/06			dwg no	51929-003
sheet index	revision sheet							sheet	3 of 4

coge code 22526

Pro/E

PDM: Rev:A

STATUS: Released

Printed: Dec 20, 2010

Tous droits strictement réservés. Reproduction ou communication o des liers interdite sous quelque forme que ce soit sans autorisation écrite du propriétaire. Propriete de c FCI. Droits de reproduction FCI.



All rights strictly reserved. Reproduction or issue to third parties in any form, whatever is not permitted without written authority from the proprietor. Property of FCI. Copyright FCI.

PRODUCT NUMBER

51929-003__
NOTE: ③

NOTES:

1. DIMENSIONS AND TOLERANCES ARE IN ACCORDANCE WITH ASME Y14.5M, 1994 UNLESS OTHERWISE SPECIFIED.

CONNECTOR NOTES:

② HOUSING MATERIAL: UL 94 V-0 GLASS FILLED HIGH-TEMP THERMOPLASTIC
POWER CONTACT MATERIAL: COPPER ALLOY
SIGNAL PIN MATERIAL: COPPER ALLOY

3. PLATING:

51929-003, 51929-003LF, PLATING SPEC SEE PRINT: 10064183.

④ MANUFACTURER'S NAME, P/N, AND DATE CODE TO APPEAR ON THIS SURFACE.

5. PRODUCT SPECIFICATION GS-12-149.
APPLICATION SPECIFICATION BUS-20-067.

6. PACKAGED IN TRAYS.

PCB NOTES:

7. ALL HOLE DIAMETERS ARE FINISHED HOLE SIZE.

⑧ MOUNTING HOLES, WHERE APPLICABLE, ARE UNPLATED.

⑨ $\varnothing .0453 \pm .0010$ [1.151 \pm 0.025] DRILLED HOLES PLATED WITH .0003 [0.008] MIN SnPb OVER .001 [0.03] TO .003 [0.08] Cu PLATING TO ACHIEVE $\varnothing .040 \pm .003$ [1.02 \pm .07] HOLE.

⑩ "DIM XXX" TO BE DETERMINED BY THE CUSTOMER.

⑪ CONNECTOR KEEP-OUT ZONE.

mat'l code		SEE NOTE 2		tolerances unless otherwise specified		CUSTOMER		FCI	
lfr	ecn no.	dr	date	linear	.XX±.01/0.X±0.3	COPY		www.fciconnect.com	
A				projection	.XXX±.005/0.XX±0.13	INCH/MM		title 3ACP + 6P + 24S	
				angles	.XXX±.0020/0.XXX±0.051	scale 1:1		VERTICAL PRESS-FIT RECEPT	
				dr	CS 01/16/06	product family PwrBlade		code 213	
				enrg	STEVEN WANG 01/16/06	size A		sheet 4 of 4	
				chr	BEER FU 01/16/06	dwg no 51929-003			
				appd	JOESPH HSIA 01/16/06				
sheet index	revision sheet								

cage code 22526

Pro/E

PDM: Rev:A

STATUS: Released

Printed: Dec 20, 2010