

REVISIONS			
REV	DESCRIPTION	DATE	APPROVED
A	ECO #5713	02/17/05	E.C.C.

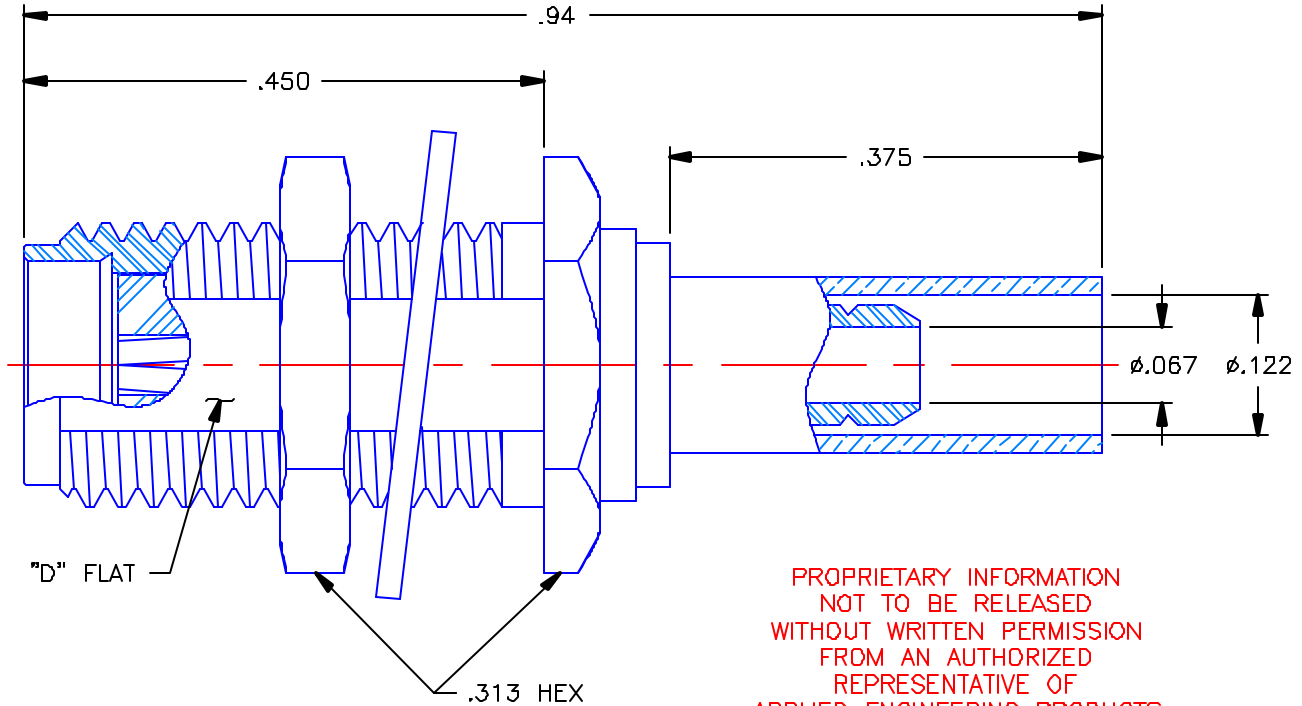

PROPRIETARY INFORMATION
NOT TO BE RELEASED
WITHOUT WRITTEN PERMISSION
FROM AN AUTHORIZED
REPRESENTATIVE OF
APPLIED ENGINEERING PRODUCTS

NOTES:

MATERIALS:

1. BODY & NUT = STAINLESS STEEL PER ASTM A582, ALLOY 303, CONDITION "A".
2. INSULATOR = VIRGIN WHITE TEFLON PER ASTM D1710, GRADE 1, TYPE I, CLASS "B".
3. CONTACT = BERYLLIUM COPPER PER ASTM B196, ALLOY C17300, TEMPER TD04.
4. LOCKWASHER = PHOSPHOR BRONZE PER ASTM B139, COPPER ALLOY C53400, TEMPER H04.
5. CRIMP SLEEVE = SEAMLESS LOWLEAD BRASS TUBE, ALLOY 330, SOFT ANNEAL TEMPER, .025/.060 GRAIN SIZE OR SEAMLESS COPPER TUBE PER ASTM B75, TYPE C12000, TEMPER: LIGHT ANNEAL O50 EXCEPT YIELD STRENGTH.
6. SHRINK SLEEVE = BLACK THERMOFIT SCL (NOT SHOWN)

FINISHES:

1. BODY & NUT = PASSIVATE PER QQ-P-35, TYPE VI.
2. CONTACT = GOLD PLATE PER MIL-G-45204, TYPE II, CLASS 1, GRADE C, OVER .00010 TO .00020 STRESS FREE SULFAMATE NICKEL PER QQ-N-290.
3. LOCKWASHER & CRIMP SLEEVE = NICKEL PLATE PER QQ-N-290, CLASS 1, GRADE G, EXCEPT .0001 TO .0002 THICK OVER .00005 TO .0001 THICK COPPER PER MIL-C-14550.

UNLESS OTHERWISE SPECIFIED DIMENSIONS ARE IN INCHES TOLERANCES ON	DWN. E.C.C.	DATE 02/17/05	 APPLIED ENGINEERING PRODUCTS 104 John W. Murphy Dr. New Haven, CT 06513
	CHKD: A.D.M.	DATE 02/17/05	
DECIMAL	ANGLE	APVD: D.J.C.	DATE 02/17/05
REFERENCE:		SMA STRAIGHT JACK BULKHEAD REAR MOUNT CRIMP TYPE FOR RG-316 & SIMILAR CABLES	
ORIGINATOR: T.C. DATE: 04/12/85		MATERIALS & FINISHES: SEE NOTES	SIZE: A FSCM NO.: 19505 DWG. NO.: 9030-9023-003 REV: A
		SCALE 6:1	SHEET 1 OF 1

9030-9023-003