

# Amphenol SOCAPEX

## RJFIELD™



# TABLE OF CONTENT

About Amphenol Socapex	4
Markets and applications	8
Other solutions and related documentations	9
Concept overview and benefits	10
Ethernet standards and appropriate solutions	11

<b>METAL RANGE</b>	<b>13</b>
RJF™	14
RJF™ - Transversally sealed and hermetic receptacle	23
RJF™ - PC tails receptacle	24
RJF™ - Plug & receptacle with 360° EMI backshell	25
RJF™ - Plug for big insulation wire up to 1.6mm	26
RJ11F	29
RJFTV™	34
RJFTV™ - Transversally sealed and hermetic receptacle	43
RJFTV™ - Stand-off receptacle	44
RJFTV™ - Reduced flange receptacle	46
RJFTV™ - Through-bulkhead receptacle	48
RJFTV™ - Plug and receptacle with 360° EMI backshell	50
RJFTV™ - Plug and receptacle for big insulation wire up to 1.6mm	57
RJFTV™ - Atex Zone 2	61
RJ11FTV - Atex Zone 2	64

<b>COMPOSITE RANGE</b>	<b>67</b>
RJFRB	68
RJF544	71

<b>CABLES AND CORDSETS</b>	<b>75</b>
Cat.5e cable and cordset	76
Cat.6 cable and cordset	77
Cat.6A cable and cordset	78
Cat.7 cable and cordset	79
Cat.7 VG95318 cable and cordset	80

<b>ADAPTORS AND ACCESS POINTS</b>	<b>83</b>
RJ45 access point	84
RJ11 to type EN3646 - PT/451 - ABS1547 adaptor	85
RJ45 to type EN3646 - PT/451 - ABS1547 adaptor	86
RJ45 to M12 adaptor	87
RJFTV™ intercoach jumper	89

<b>ACCESSORIES</b>	<b>91</b>
Standard protective cap - RJF™	92
Standard protective cap - RJFTV™	93
Standard protective cap - RJ11F	94
Standard protective cap - RJ11FTV	95
Self-closing cap - RJF™	96
Self-closing cap - RJFTV™	97
Standard protective cap - RJFRB and RJF544	98
Panel gasket and tool	99

# TABLE OF CONTENT

## ASSEMBLY INSTRUCTIONS

**101**

RJF™	102
RJ11F	103
RJFTV™	104
RJFRB	105
RJF544	106

## HOW TO ORDER

**109**

RJF™	110
RJF™ - Transversally sealed and hermetic	111
RJ11F	112
RJFTV™	113
RJFTV™ - Transversally sealed and hermetic	114
RJFTV™ - Stand-off receptacle	115
RJFTV™ - Reduced flange receptacle	116
RJFTV™ - Through-Bulkhead receptacle	117
RJFTV™ - Atex zone 2	118
RJ11FTV - Atex zone 2	119
RJFRB	120
RJF544	121
Cable	122
Cordset	123
Standard protective cap	124

# ABOUT AMPHENOL SOCAPEX



## Proven excellence in interconnect solutions

Since **1947**, Amphenol Socapex has prescribed, designed and manufactured reliable and innovative interconnection solutions for **harsh environments**, specializing in standard and customized electrical and fiber optic connectors, contacts, accessories and cabling solutions. Located in the **Mont Blanc** region of France and Pune in India, Amphenol Socapex has a presence in over 100 countries around the world. Amphenol Socapex is part of the international **Amphenol Corporation**.



**1000+** employees



Net Sales 2021: **92 M€**  
72% Export - 28% France



Two facilities :  
**Thyez** (France), **Pune** (India)

OUR HISTORY

**1947**

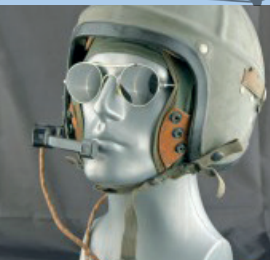

- Socapex creation in Suresnes, France
- 1<sup>st</sup> radio connector

**1956-57**

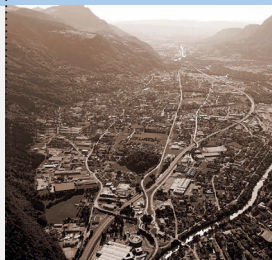

- Manufacturing unit in Cluses (74), France
- Thomson-CSF becomes primary shareholder

**Early 1960's**



- 1<sup>st</sup> board level connectors: HE8
- 1<sup>st</sup> "licence Bendix" manufactured connectors
- SL Series launch

**1973**



- New factory 13 000 m<sup>2</sup> in Thyez (74) France with 250 people

**1975**



- Production of 38999 connectors

**2014-2017**

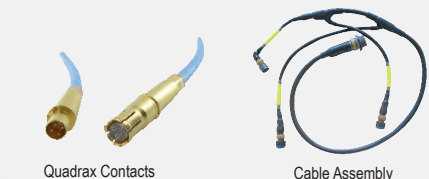

- New Cable Assembly workshop
- New Contact Manufacturing workshop

**Today and tomorrow | New technologies**



Miniaturization High-speed signals Rugged Ethernet Fiber optics  
 Miniaturization ROHS solutions Power Rugged Ethernet Power  
 Fiber optics ROHS solutions  
 Advanced Materials (composite) Power  
 Miniaturization ROHS solutions

# INTERNATIONAL EXPERTISE



## Our expertise has no boundaries

### Integrated Production in France & India

- **24 000 m<sup>2</sup>** manufacturing capacity on 2 sites
- Design centers in **France** and **India**
- State-of-the-art manufacturing technology

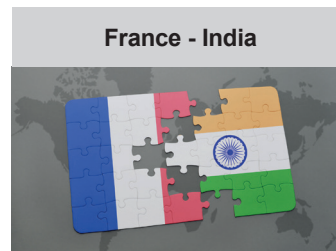

## Our markets



### Military

Communication Systems - Radios - C4ISR /  
Ground vehicles - Vetronics / Marine / Missiles



### Aviation

Commercial & military / Avionics /  
Engines / Landing gear / Actuators

1986	1995-96	2004	2005	2010's
<p>- Amphenol becomes primary shareholder</p>	<p>- Expanded Beam connector CTOS launch - Headquarters transferred to Theyez</p>	<p>- RJ Field launch, "Award Electronica"</p>	<p>- Opening of manufacturing site in Pune, India</p>	<p>- LuxBeam™ and HDAS launch</p>

## Today and tomorrow | Sustainable development



**Respect for nature and the environment**  
 Optimization of natural resources  
 Recycling  
 Goodwill  
 Waste Management  
 Optimization of natural resources  
 Goodwill  
 Waste Management  
 Respect for nature and the environment  
 Recycling

# PRODUCING FASTER, SMALLER, STRONGER CONNECTORS...



## Technologies & innovation

<p><b>Technological Center</b></p>	<p><b>High-Speed Expertise</b></p>	<p><b>Materials Expertise</b></p>	<p><b>Eco-responsibility</b></p>
<p><b>Engineering Laboratory for product testing and qualification, product expertise and metrology</b></p> <ul style="list-style-type: none"> <li>- Mechanical and electrical skills</li> <li>- RF and fiber optics expertise</li> </ul>	<p><b>Strong expertise in high-speed signals</b></p> <ul style="list-style-type: none"> <li>- 3D EM simulation software &amp; EM models</li> <li>- Time Domain and frequency domain (VNA 20GHz, TDR and eye diagram)</li> </ul>	<p><b>Focus on materials expertise and manufacturing techniques to produce faster, smaller and stronger products</b></p> <ul style="list-style-type: none"> <li>- 3D CAD mechanical software, simulation &amp; analysis</li> <li>- Disruptive metal alloys, additive manufacturing</li> </ul>	<p><b>Sustainable environment approach, with pro-active management of regulations (REACH / RoHS / Conflict minerals...)</b></p> <ul style="list-style-type: none"> <li>- New materials development, plating, and suitable processes</li> <li>- Recycling and rational resources consumption</li> </ul>

## Our workshops

Our workshops located in France & India provide consistent quality adapted to your volume requirements.

- Tooling** : Tools for our different activities : molding, machining, assembly
- Molding** : Solid expertise in thermoplastic elastomer and thermoset molding
- Machining** : Manufacturing of cylindrical shells from 10 to 90 mm in diameter and rectangular shells
- Screw Machining** : Cylindrical production parts up to 10 mm in diameter
- Plating** : Plating with cadmium, nickel, electroless nickel, silver, black zinc nickel, gold
- Assembly** : Connector and harness assembly (electrical & optical)

## Our certifications

Certified Management System	Certified Management System	Certified Management System	Certified Management System

Product certifications : MIL-DTL38999, EN3645, EN3155, VG

## Our memberships



Member of CMG (Connecting Manufacturing Group) Consortium

# DELIVERING GREAT CUSTOMER EXPERIENCE

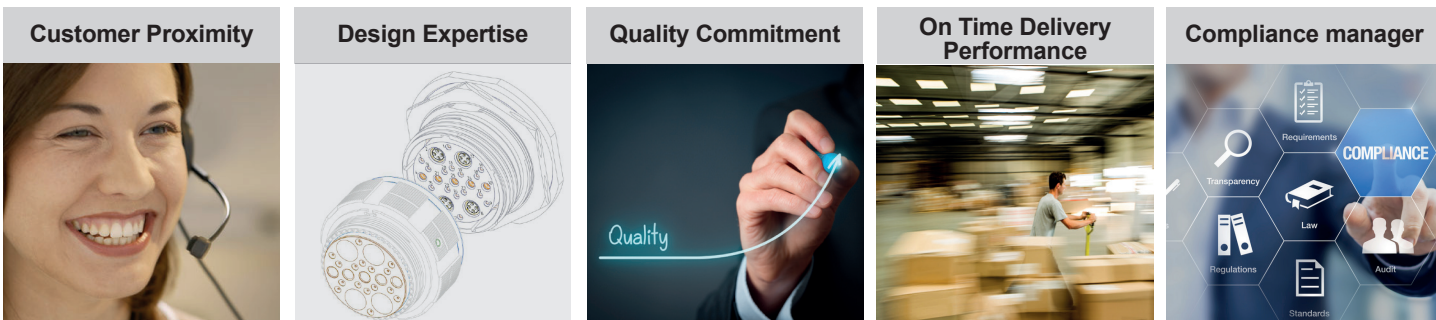

► We have a strong reputation for helping customers solve their toughest challenges. This approach of serving your needs is ingrained in our company – from our sales team to our product development engineers.

## A partner you can trust



## Buy our solutions

You can access our solutions through our global network of sales offices or through our distributors.

### Field Sales Team :

- 12 in France
- 15 in Europe
- 100+ in North America and rest of the world.
- 5 Business Development Managers supporting local sales force Europe, North America and the rest of the world

### Technical Support & Multilingual Customer Service :

15 people

### Worldwide Distribution Network :

Including qualified distributors (QPL approved) for assembling : MIL-DTL-38999, PT/451/VG95328 & Fiber Optics connectors



# MARKETS AND APPLICATIONS



## Military vehicles

Ground radios shelters  
Ground vehicles  
Battlefield  
Communication systems



## C5ISR

Threat detection system  
Soldier wearable equipment  
Rugged computer & digital radio  
Satellite reception unit



## Military Avionics & Airframe

Power unit  
Aircraft  
Radar  
Display unit  
Flight control system



## Commercial Avionics & Airframe

Landing gear  
Cockpit  
Ground power supply  
Engine Flowmeter



## Missiles & UAVS

Air missiles and UAVS  
Ground control station & launchers



## Navy

Navigation guidance



## Industrial

Automation  
Transportation  
Nuclear power station  
Robotics





# OTHER SOLUTIONS AND RELATED DOCUMENTATIONS

All our documentations are available in PDF format on our website : [www.amphenol-socapex.com](http://www.amphenol-socapex.com)



**Catalog USB Field™**  
DOC-001035-ANG



**Catalog Rugged Ethernet Switch and Media Converters**  
DOC-001034-ANG

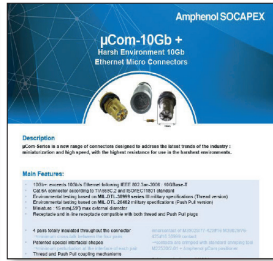

**Brochure μCom-10Gb+ Ethernet Micro Connectors**  
DOC-000015-ANG

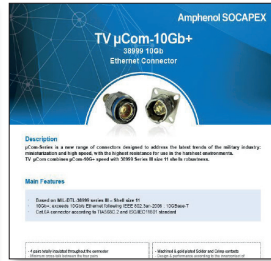

**Brochure TV μCom-10Gb+ Ethernet Connector**  
DOC-001014-ANG



**Brochure RJF TV Reduced Flange Ethernet connector systems for harsh environment**  
DOC-001013-ANG



**Brochure USB3F TV Reduced Flange**  
DOC-001012-ANG



**Brochure MDP FTV Mini DisplayPort connection system for harsh environment**  
DOC-001025-ANG



**Brochure HDMI FTV HDMI connection system for harsh environment**  
DOC-001036-ANG



**Brochure RJF 6A Cat5A 10Gb Ethernet connection system for harsh environment**  
DOC-001021-ANG



**Brochure RJF TV6A Cat5A 10Gb Ethernet connection system for harsh environment**  
DOC-001020-ANG



**Brochure μCom & TvμCom USB3.2 Gen1 Harsh Environment Connectors**  
DOC-001032-ANG



**Brochure CapLock & PlugLock Locking accessories for 38999, RJF TV, USBF TV Connectors and Caps...**  
DOC-001043-ANG

# CONCEPT OVERVIEW AND BENEFITS

## 5 TOP REASONS to use RJFIELD™

### # 1 Military. Ruggedized. Connectors

Our concept is simple : use standard, well-know, military connectors as MIL-DTL-38999 series III and MIL-DTL-26482 series I to reinforce standard industrial connectors as RJ45 or USB.



### # 2 No tool. No cabling. RJ Stop™

Our patented RJStop enables you to use a standard RJ45 cordset and mount itself without any cabling operation or tool.



### # 3 Electric continuity Metallized inserts

Our solutions provide a total shielding continuity per the metallisation of parts in the receptacle.



### # 4 Four codings. Only one reference

Our connectors, plugs and receptacles, can be configured in four different codings with the same reference.

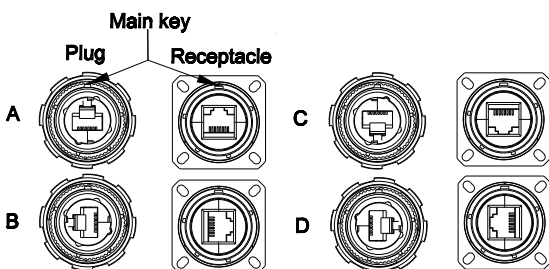

### # 5 Modifiable. Repairable. Removal inserts

Our parts can be changed as simply as the assembly, using a dedicated tool or simply by hands. This allows to remove the cordset, change the coding option or repair the solution.



# ETHERNET STANDARDS AND APPROPRIATE SOLUTIONS

	Cat.5e	Cat.6	Cat.6A	Cat.7
Standard	Ethernet Class D per ISO/IEC 11801 Cat.5e per TIA/EIA568B	Ethernet Class E per ISO/IEC 11801 Cat.6 per TIA/EIA568B	Ethernet Class Ea per ISO/IEC 11801 Cat.6A per TIA/EIA568B	Ethernet Class F per ISO/IEC 11801 Cat.7 per TIA/EIA568B
Data Rate	1 Gb/s	1 Gb/s	10 Gb/s	10 Gb/s
Frequency	100 MHz	250 MHz	500 MHz	600 MHz
RJF™	✓	✓	✓	
RJFTV™	✓	✓	✓	
RJF544	✓	✓		
RJFRB	✓	✓	✓	
Cable and cordset	✓	✓	✓	✓
Adaptor and access point	✓			

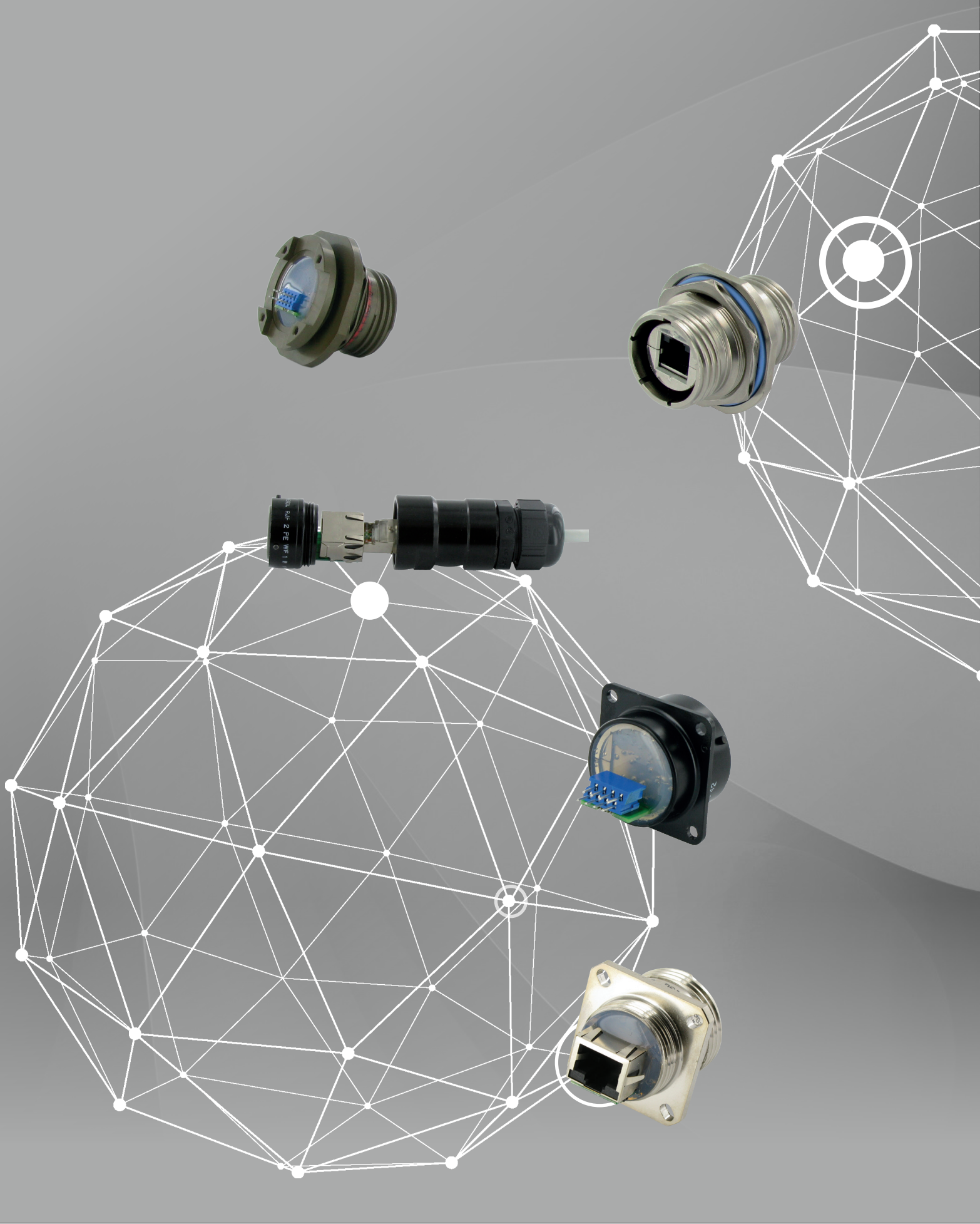

# METAL RANGE



## Table of contents

<b>METAL RANGE</b>		<b>13</b>
RJF™		14
RJF™ - Transversally sealed and hermetic receptacle		23
RJF™ - PC tails receptacle		24
RJF™ - Plug & receptacle with 360° EMI backshell		25
RJF™ - Plug for big insulation wire up to 1.6mm		26
RJ11F		29
RJFTV™		34
RJFTV™ - Transversally sealed and hermetic receptacle		43
RJFTV™ - Stand-off receptacle		44
RJFTV™ - Reduced flange receptacle		46
RJFTV™ - Through-bulkhead receptacle		48
RJFTV™ - Plug and receptacle with 360° EMI backshell		50
RJFTV™ - Plug and receptacle for big insulation wire up to 1.6mm		57
RJFTV™ - Atex Zone 2		61
RJ11FTV - Atex Zone 2		64



## Description

This connector has been Amphenol's best seller for decades. This RJF™ connector dedicated for Ethernet transmission is a derivative from MIL-DTL-26482 J with a shell size 18. The bayonet coupling is quick, audible and visual, facilitating the data transmission and acquisition in harsh environment.

This solution has several advantages. The assembly of your solutions is easy to install because you don't need any tool, thanks to the patented RJStop system. You can choose between four different codings on the plug and receptacle side. With the help of the dedicated tool, you can remove the insert of the receptacle in order to change the coding if needed. You can also use it for reparation or maintenance. Everything can be done in place. The complete solution is metallized and united when connected in order to transmit the electrical continuity from the cordset to the panel.

The following pages list all complementary configurations that you might need on your system such as sealed and hermetic receptacles, 360° EMI solutions for reinforced shielding or whether special plugs for big insulations wire.

## Main features

### MAIN CHARACTERISTICS

- Bayonet coupling ("Audible & Visual" coupling signal )
- Robust metallic shells based on MIL-DTL-26482 J - Shell size 18
- RJ45 cordset retention in the plug: 100 N in the axis
- Mating cycles: 500 min
- Sealed against fluids and dust (IP68)
- Shock, vibration and traction resistant
- No cabling operation in field and no tools required
- Mechanical coding / polarization (4 positions)
- Compatible with cable diameter from 6 mm [0.236 in] to 12 mm [0.512 in]. For smaller diameters, please consult us.

### ENVIRONMENTAL PROTECTION

- Sealing: IP68
- Salt spray:
  - 48 h with nickel plating over aluminium shell ✓
  - 96 h with black coating over aluminium shell ✓
  - 500 h black zinc nickel over aluminium shell ✓
  - 500 h with olive drab cadmium over aluminium shell
- Fire retardant / Low smoke: UL94 V0 and EN45545
- Vibrations: 10-500Hz, 10g, 3 axes: no discontinuity >10 nano s
- Shocks: IK06 ► weight of 250 g drop from 40cm [15.75 in] onto connectors (mated pair)
- Humidity: 21 days, 43°C, 98% humidity
- Temperature range: -40°C / +85°C

### DATA TRANSMISSION

- 10 BaseT, 100 BaseTX and 1000 BaseT networks
- Cat.5e per TIA/EIA 568B and ClassD per ISO/IEC 11801
- Cat.6 per TIA/EIA 568B and ClassE per ISO/IEC 11801
- Cat.6A per TIA/EIA 568B and ClassEa per ISO/IEC 11801

### APPLICATIONS

- Battlefield communication systems
- C5ISR
- Data acquisition and transmission in harsh environment
- Navy
- Rail Mass Transit
- Industrial process control
- Robotics
- CNC machines
- Oil & Gas

**How to order :** Please refer to page 110

## Back terminations

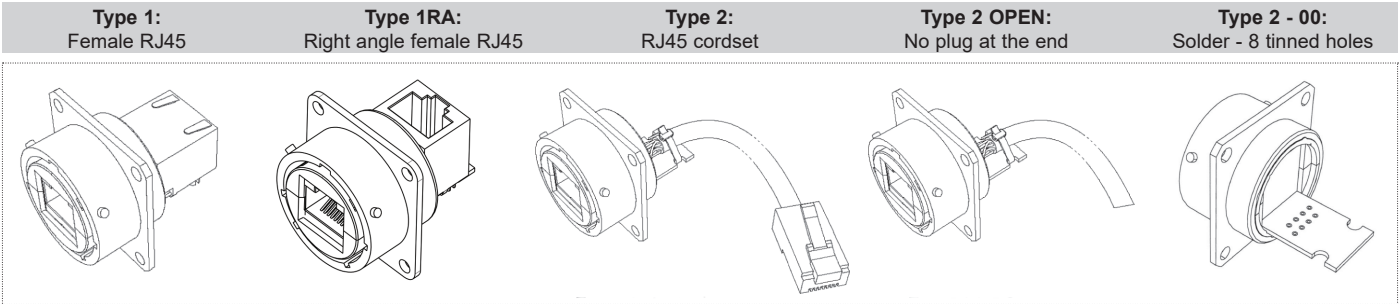

## Overall dimension

### Plug - Shell type 6 - Plastic gland

Part number type : **RJF 6 X**

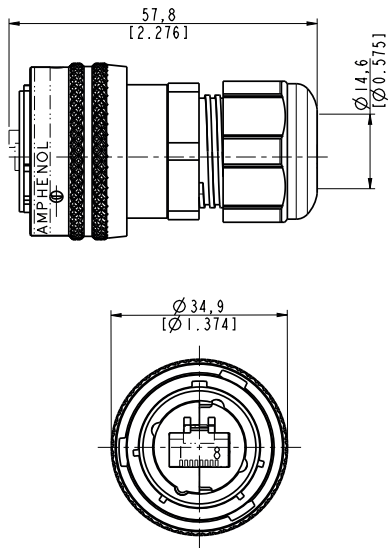

#### Components

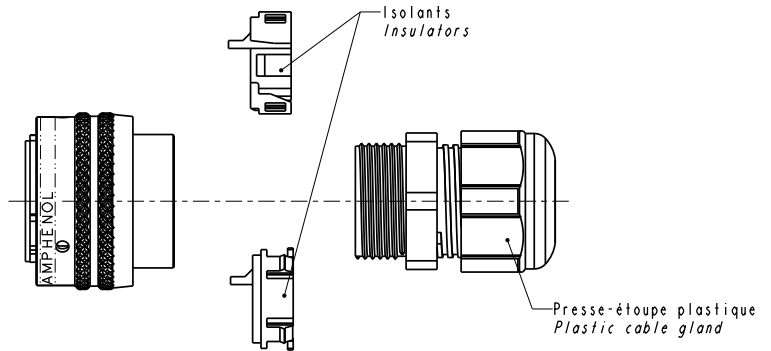

### Plug - Shell type 6 - Metal gland

Part number type : **RJF 6M X**

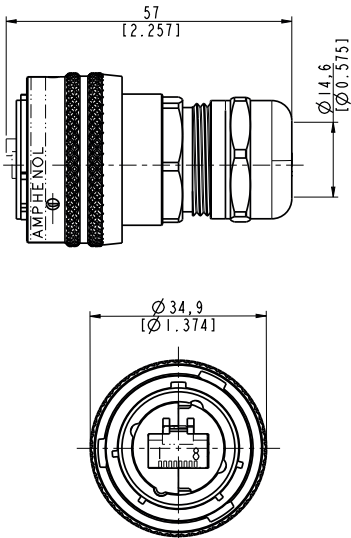

#### Components

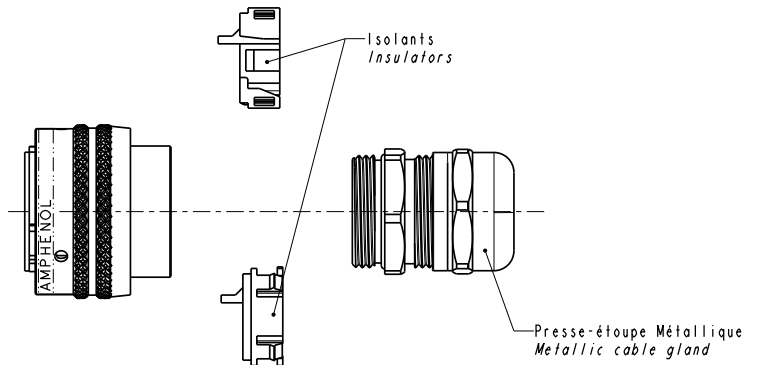

## Overall dimension

### Receptacle - Square flange receptacle - 4 mounting holes - Shell type 2 - Back termination type 1

Part number type (Cat.5e) : **RJF 2 1 X**  
 Part number type (Cat.6) : **RJF 6 2 X 1 X**

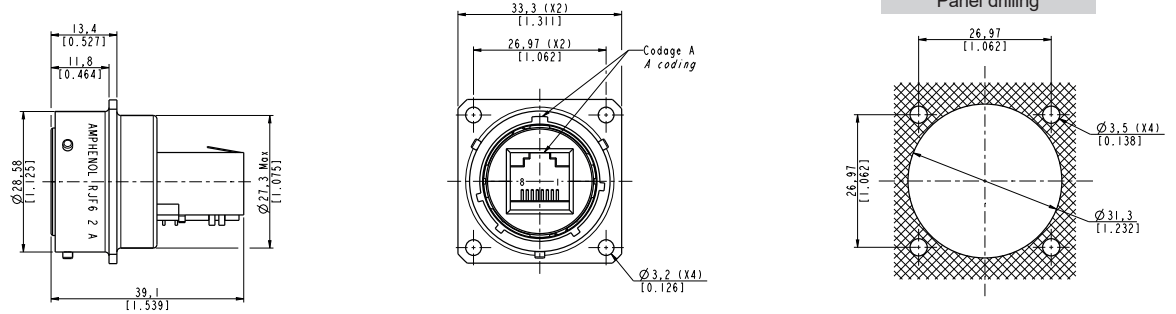

Part number type (Cat.6A) : **RJF 6A 2 X 1 X**

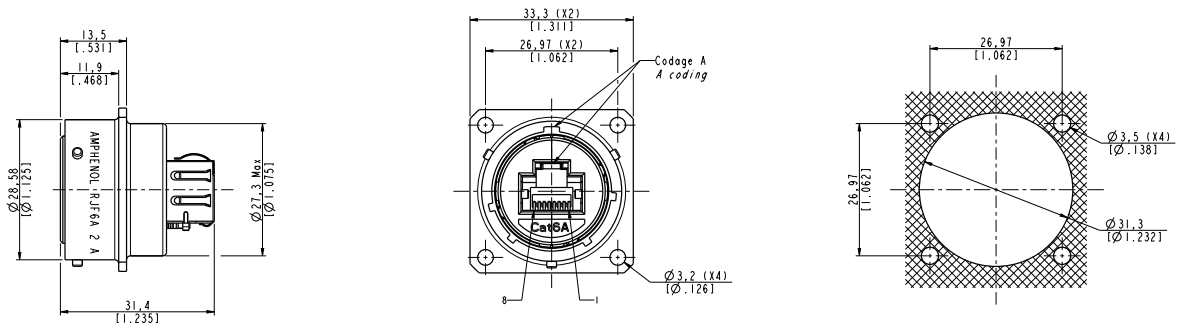

### Receptacle - Square flange receptacle - 4 mounting holes - Shell type 2 - Back termination type 1RA

Part number type (Cat.5e) : **RJF 2 1RA X**

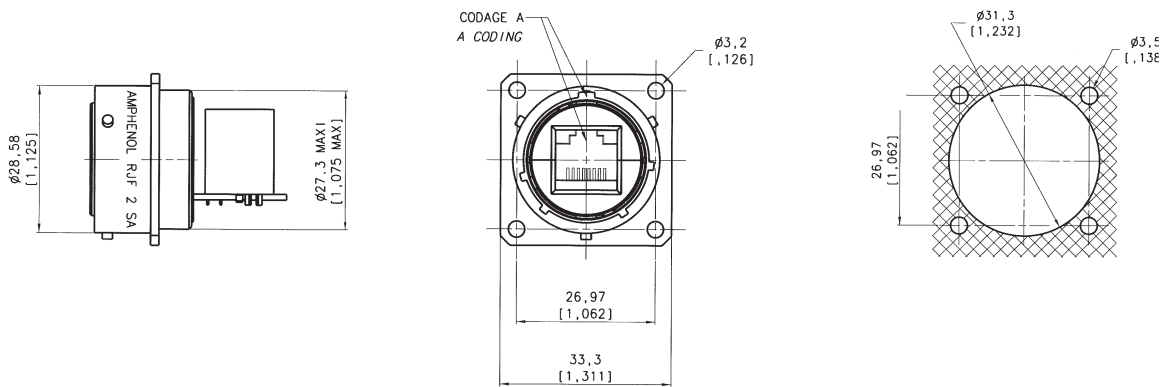

Part number type (Cat.6A) : **RJF 6A 2 X 1RA X**

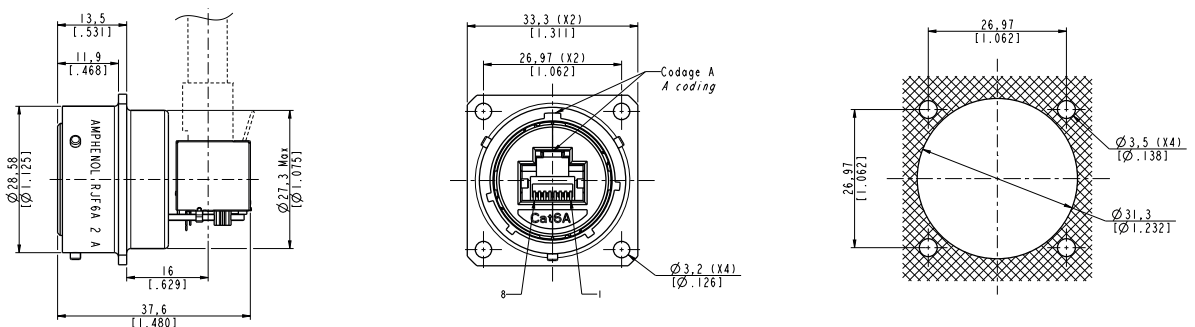



## Overall dimension

### Receptacle - Square flange receptacle - 4 mounting holes - Shell type 2 - Back termination type 2

Part number type (Cat.5e) : **RJF 2 2 X XX 100BTX**

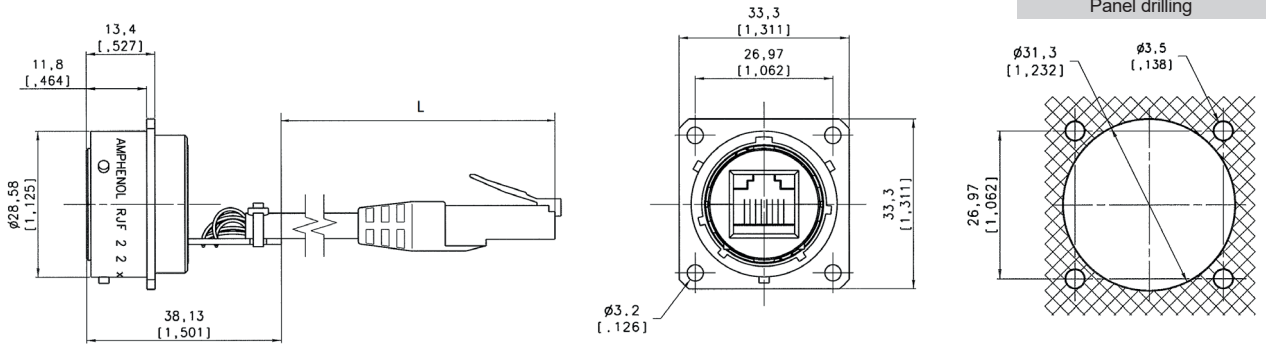

Part number type (Cat.5e) : **RJF 2 2 X XX OPEN**

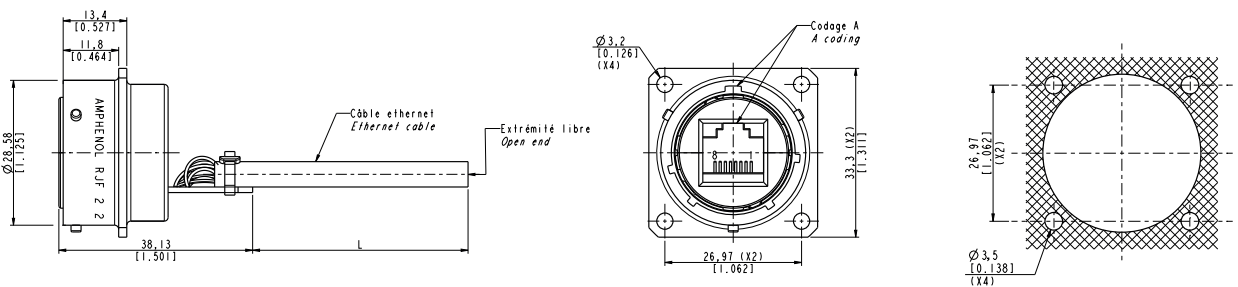

Part number type (Cat.5e) : **RJF 2 2 X 00**

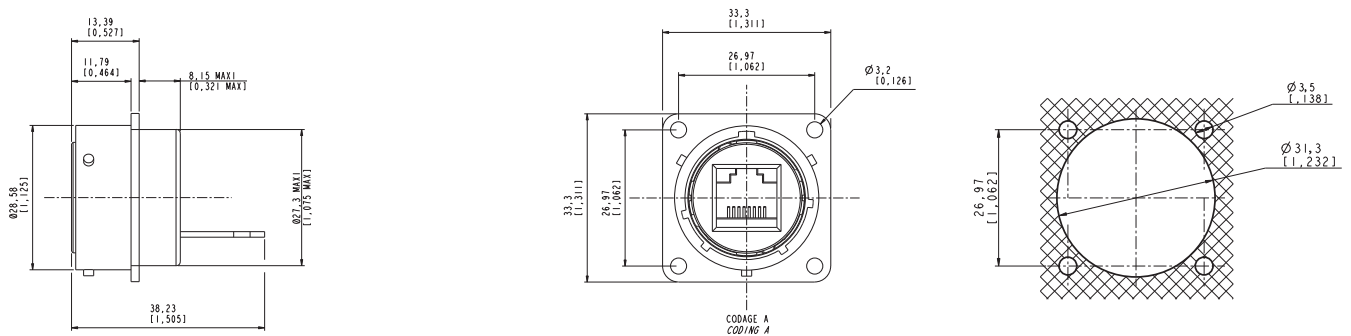

**Important note:**

- To choose your coding orientation, please refer to "Assembly instructions" page 102

## Overall dimension

### Receptacle - Jam nut receptacle - Hexagonal nut mounting - Shell type 7 - Back termination type 1

Part number type (Cat.5e) : **RJF 7 1 X**  
 Part number type (Cat.6) : **RJF 6 7 X 1 X**

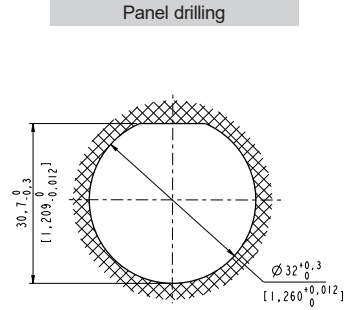
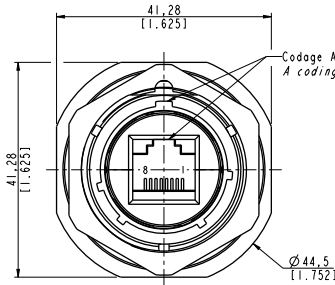
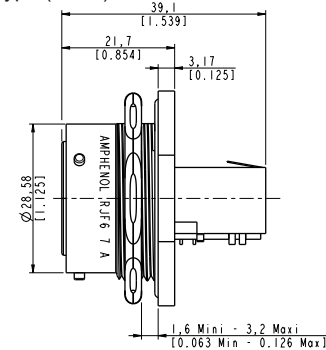

Part number type (Cat.6A) : **RJF 6A 7 X 1 X**

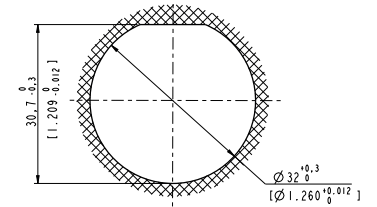
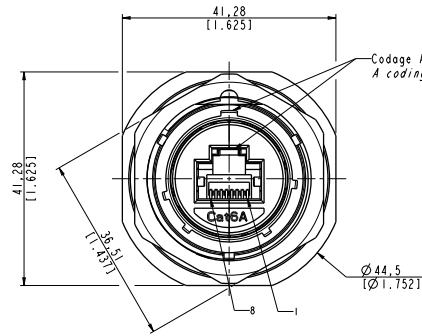
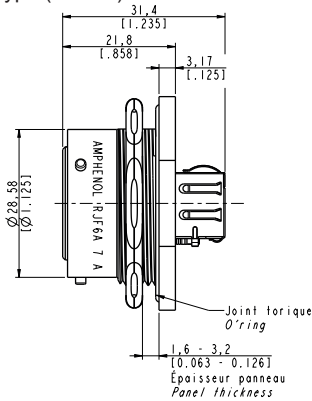

### Receptacle - Jam nut receptacle - Hexagonal nut mounting - Shell type 7 - Back termination type 1RA

Part number type (Cat.5e) : **RJF 7 1RA X**

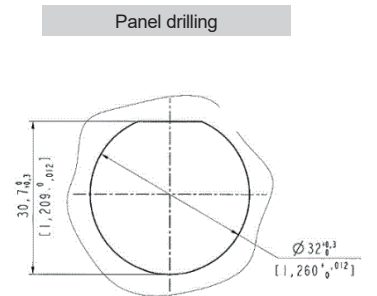
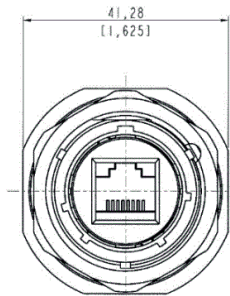
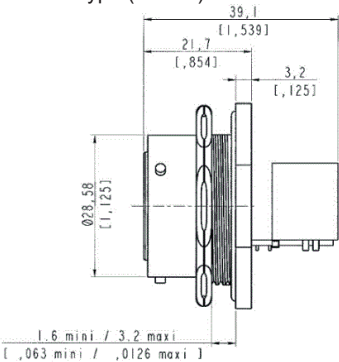

Part number type (Cat.6A) : **RJF 6A 7 X 1RA X**

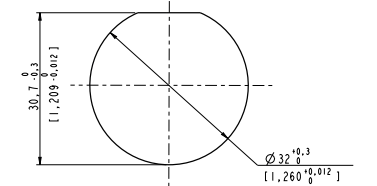
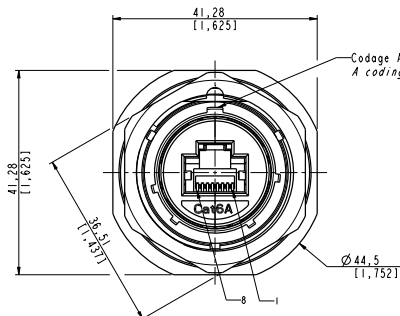
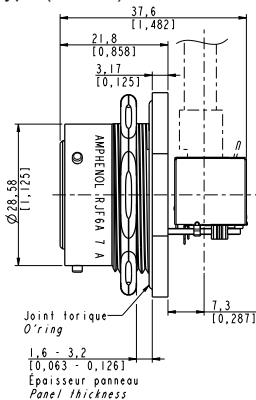

## Overall dimension

Receptacle - Jam nut receptacle - Hexagonal nut mounting - Shell type 7 - Back termination type 2

Part number type (Cat.5e) : **RJF 7 2 X XX 100BTX**

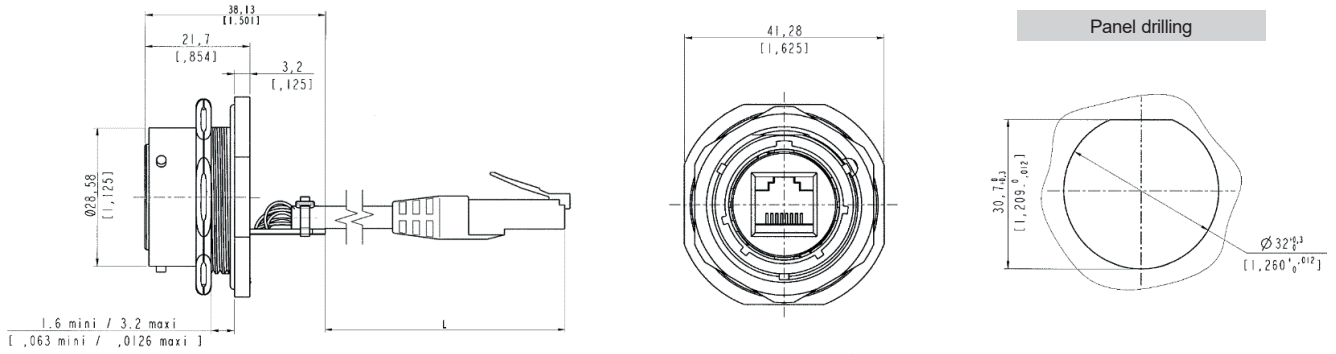

Part number type (Cat.5e) : **RJF 7 2 X XX OPEN**

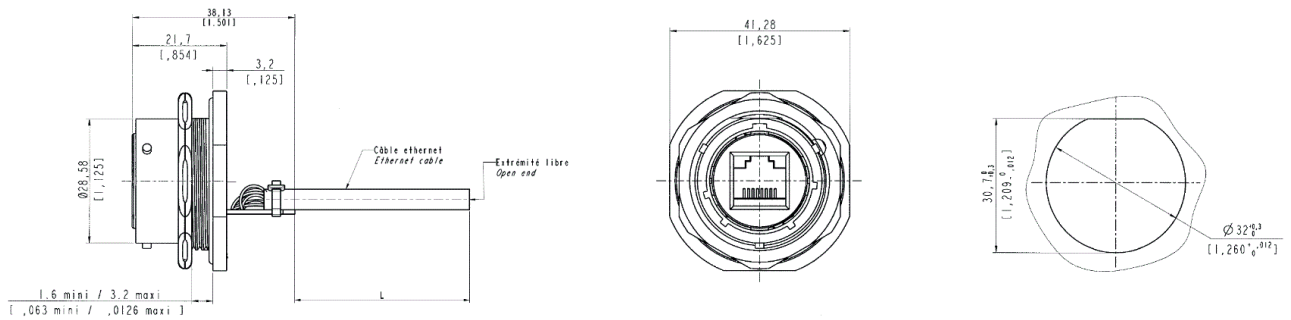

Part number type (Cat.5e) : **RJF 7 2 X 00**

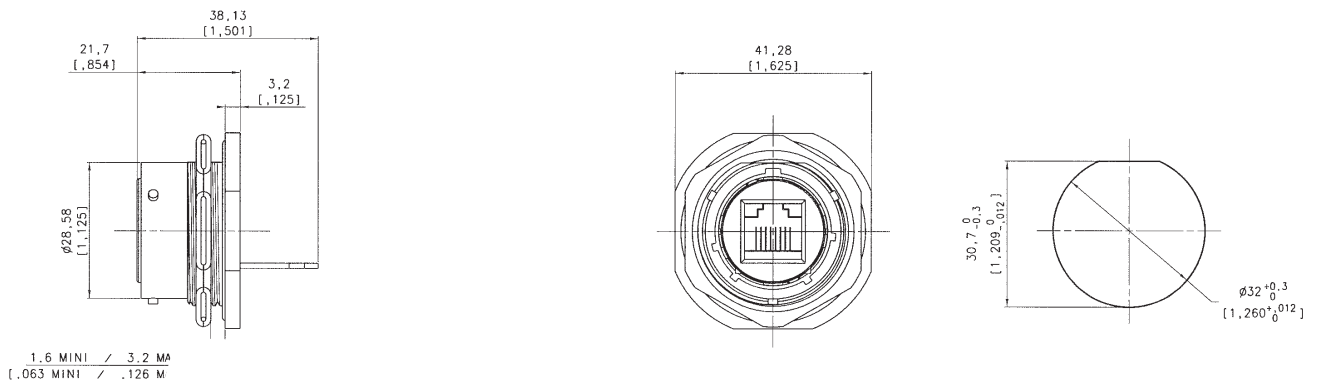

**Important note:**

- To choose your coding orientation, please refer to "Assembly instructions" page 102

## Overall dimension

## Receptacle - Square flange receptacle - 4 mounting holes - Shell type 2 - Backshell with plastic gland

Part number type (Cat.5e) : **RJF 2 PE 1 X**  
 Part number type (Cat.6) : **RJF 6 2 X PE 1 X**

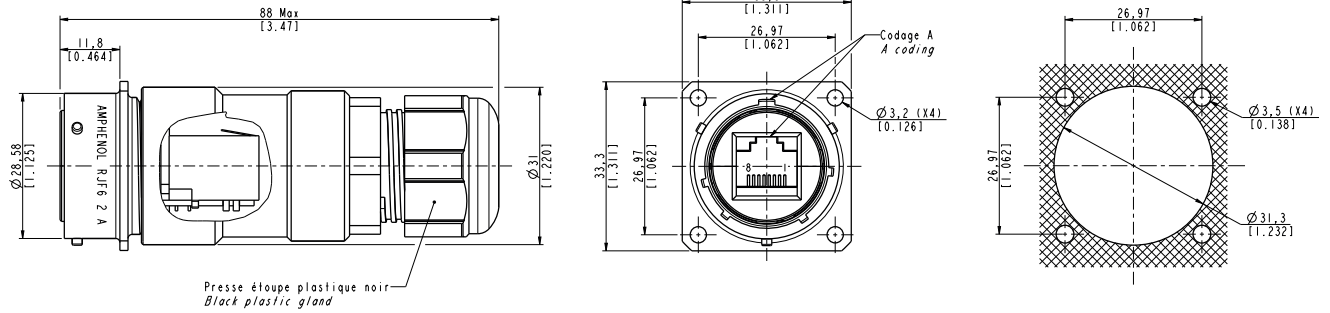

Part number type (Cat.6A) : **RJF 6A 2 X PE 1 X**

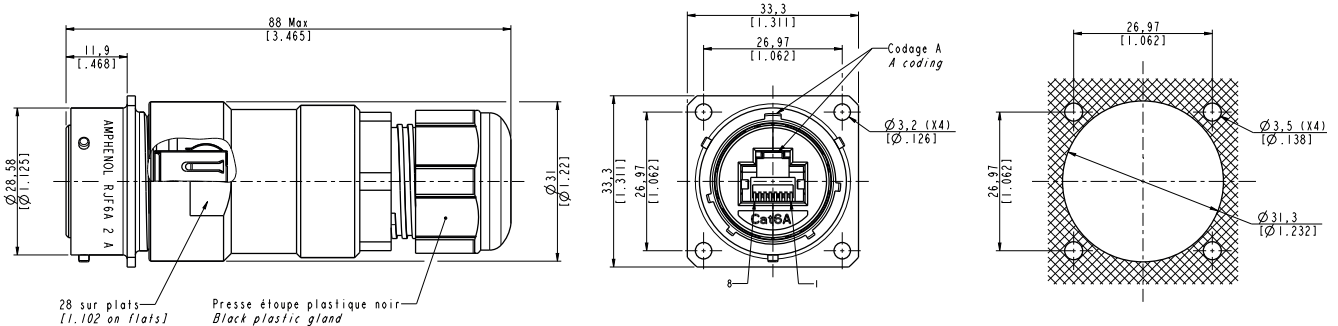

## Receptacle - Square flange receptacle - 4 mounting holes - Shell type 2 - Backshell with metallic gland

Part number type (Cat.5e) : **RJF 2 PEM 1 X**  
 Part number type (Cat.6) : **RJF 6 2 X PEM 1 X**

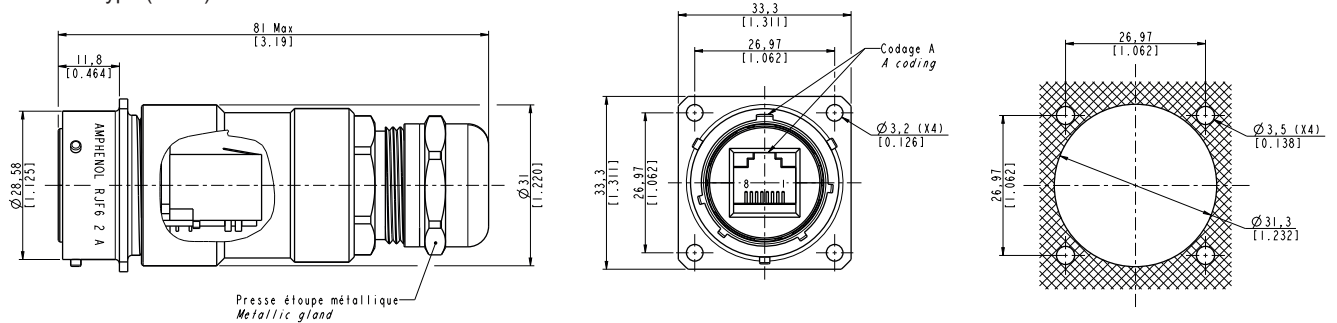

Part number type (Cat.6A) : **RJF 6A 2 X PEM 1 X**

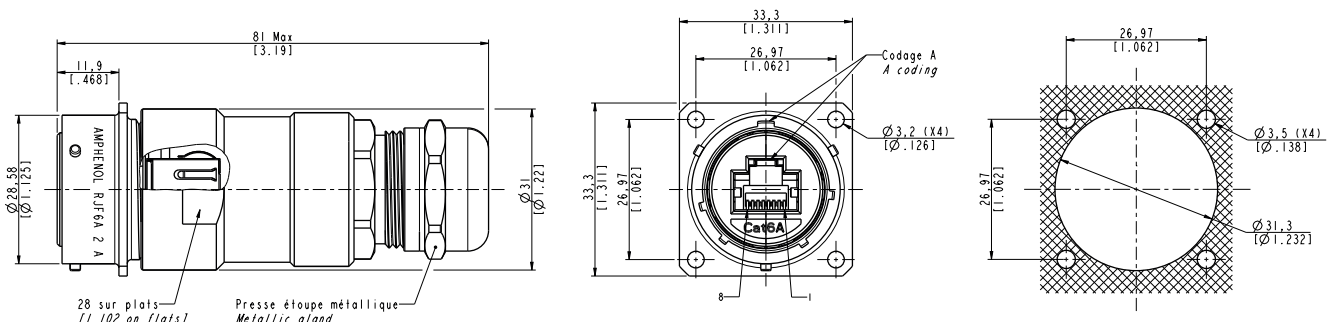

## Overall dimension

### Receptacle - Jam nut receptacle - Hexagonal nut mounting - Shell type 7 - Backshell with plastic gland

Part number type (Cat.5e) : **RJF 7 PE 1 X**  
 Part number type (Cat.6) : **RJF 6 7 X PE 1 X**

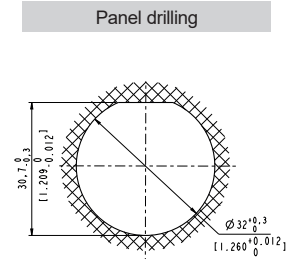
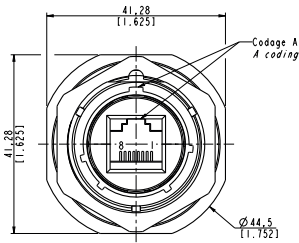
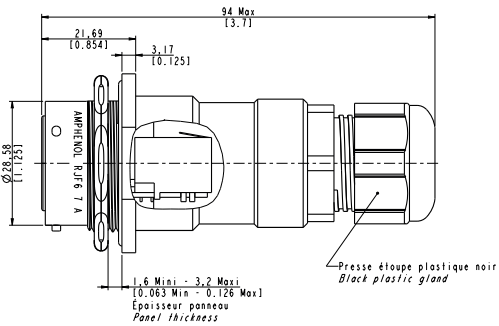

Part number type (Cat.6A) : **RJF 6A 7 X PE 1 X**

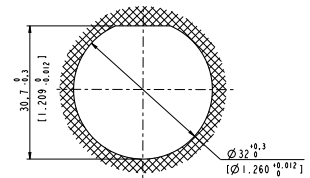
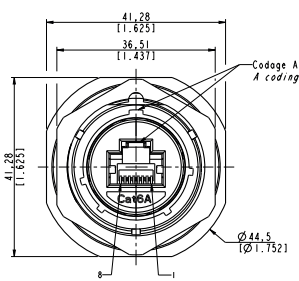
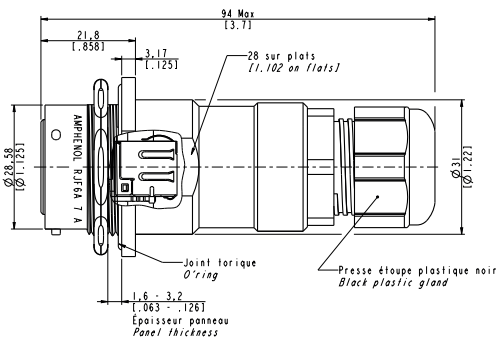

### Receptacle - Jam nut receptacle - Hexagonal nut mounting - Shell type 7 - Backshell with metallic gland

Part number type (Cat.5e) : **RJF 7 PEM 1 X**  
 Part number type (Cat.6) : **RJF 6 7 X PEM 1 X**

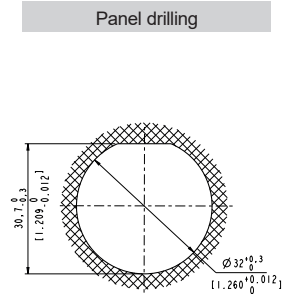
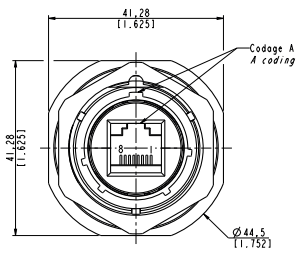
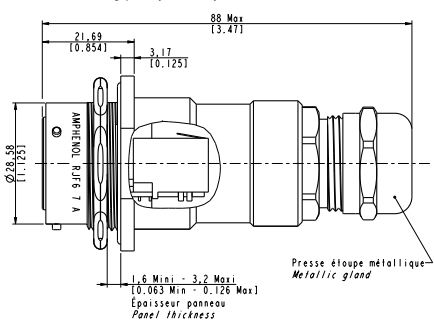

Part number type (Cat.6A) : **RJF 6A 7 X PEM 1 X**

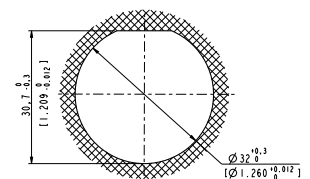
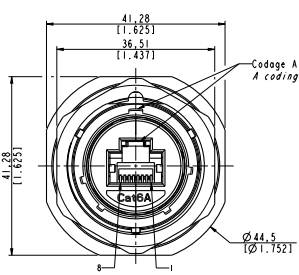
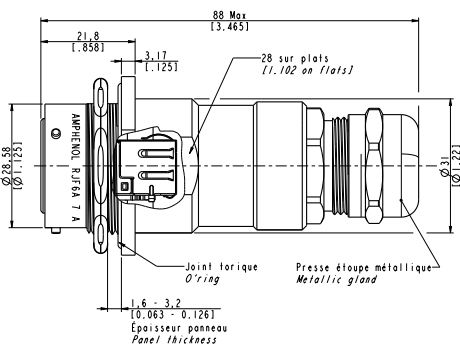

## Overall dimension

### Receptacle - In line receptacle - Without flange - Plastic gland

Part number type (Cat.5e) : **RJF 2 PEWF 1 X**  
 Part number type (Cat.6) : **RJF 6 2 X PEWF 1 X**

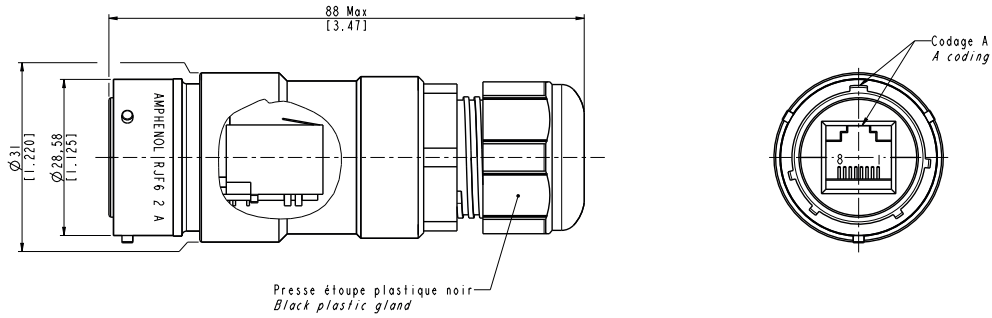

Part number type (Cat.6A) : **RJF 6A 2 X PEWF 1 X**

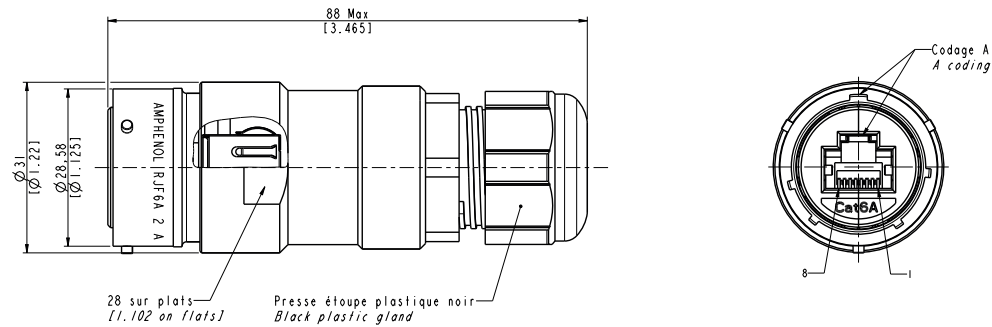

### Receptacle - In line receptacle - Without flange - Metal gland

Part number type (Cat.5e) : **RJF 2 PEMWF 1 X**  
 Part number type (Cat.6) : **RJF 6 2 X PEMWF 1 X**

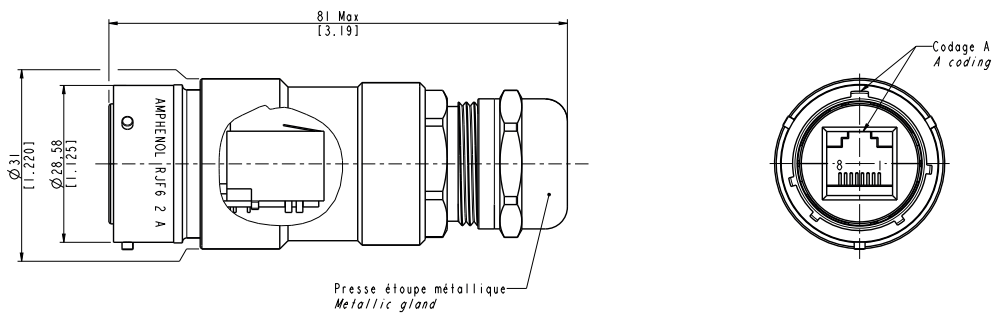

Part number type (Cat.6A) : **RJF 6A 2 X PEMWF 1 X**

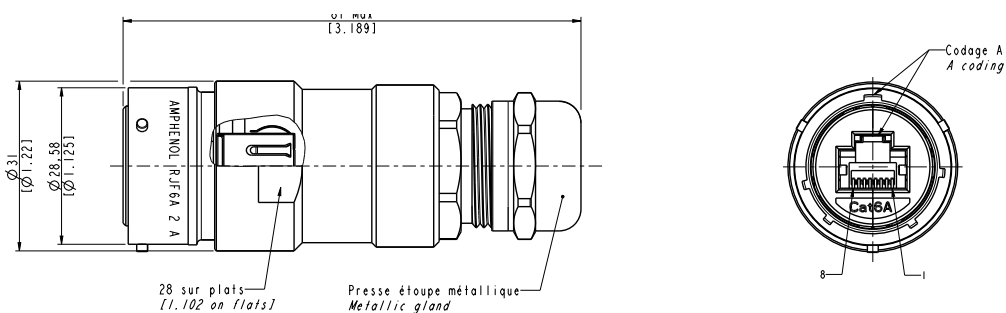

# RJF™ - TRANSVERSALLY SEALED AND HERMETIC RECEPTACLE



## Description

The transversally sealed receptacle is in all aspects equivalent to the standard and in addition, is improved with compound at the rear of the receptacle. This prevents the sealing of the receptacle when unmated with his plug or protective cap.

The hermetic solution, as the transversally sealed one, is compounded at the rear of the receptacle. Helium leakage is less than  $1.10 \cdot 10^{-6}$  cm<sup>3</sup> per second [0.1 micron cubit ft per hour] at one bar [15 psi] pressure differential. The test is 100% done on all of these hermetic receptacles.

## Main features

### MAIN CHARACTERISTICS

- Robust metallic shells based on MIL-DTL-26482 J - Shell size 18
- A complete IP68 sealing of the receptacle (even with no plug or no protective cap mated) is added
- External dimensions are the same as the standard RJF™ series- Bayonet coupling ("Audible & Visual" coupling signal )
- RJ45 cordset retention in the plug: 100 N in the axis
- Mating cycles: 500 min
- Mechanical coding / polarization (4 positions)

### DATA TRANSMISSION

- 10 BaseT, 100 BaseTX and 1000 BaseT networks
- Cat.5e per TIA/EIA 568B and ClassD per ISO/IEC 11801
- Cat.6 per TIA/EIA 568B and ClassE per ISO/IEC 11801
- Cat.6A per TIA/EIA 568B and ClassEa per ISO/IEC 11801

### ENVIRONMENTAL PROTECTION

- Sealing: IP68
- Salt Spray:
  - 48 h with nickel plating over aluminium shell ✓
  - 96 h with black coating over aluminium shell ✓
  - 500 h black zinc nickel over aluminium shell ✓
  - 500 h with olive drab cadmium plating over aluminium shell
- Fire retardant/Low smoke: UL94 V0 and EN45545
- Vibrations: 10 – 500 Hz, 10 g, 3 axes: no discontinuity >10 nano s.
- Shocks: IK06 ► weight of 250 g drop from 40 cm [15.75 in] onto connectors (mated pair)
- Humidity: 21 days, 43°C, 98% humidity
- Temperature range: - 40°C / +85°C

### APPLICATIONS

- Battlefield communication systems
- C5ISR
- Data acquisition and transmission in harsh environment
- Optronics
- Navy
- Rail Mass Transit
- Industrial process control
- Robotics
- CNC machines
- Oil & Gas

### Important note:

- Due to the compound, the coding orientation has to be define in the reference.
- To choose your coding orientation, please refer to "Assembly instructions" page 102

**How to order :** Please refer to page 111

# RJF™ - PC TAILS RECEPTACLE



## Description

These receptacles can be soldered directly on your PCB. A compound insures a transversal sealing and good performance in high vibration environments. They can be connected with standard RJF™ plugs.

## Overall dimension

Receptacle - Square flange receptacle - 4 mounting holes - Shell type 2 - PC tails receptacle

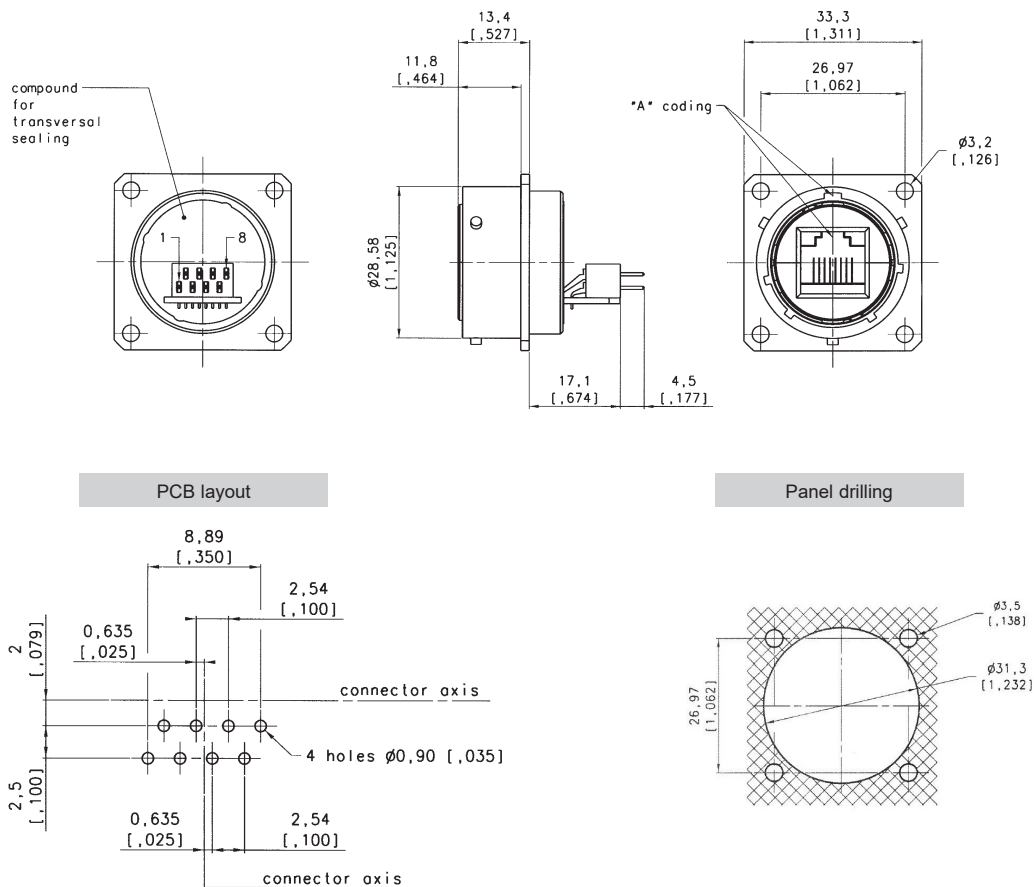

### Important note:

- Due to the compound, the coding orientation has to be define in the reference.
- To choose your coding orientation, please refer to "Assembly instructions" page 102

Data transmission	Part number	Plating
Cat.5e	RJF 2S X 5 B	Black coating ✓
	RJF 2S X 5 N	Nickel ✓
	RJF 2S X 5 G	Olive drab cadmium
	RJF 2S X 5 ZN	Black zinc Nickel ✓

✓ : RoHS compliant



# RJF™ - PLUG AND RECEPTACLE WITH 360° EMI BACKSHELL

## Description

This RJF™ kit includes all components necessary to build up a totally 360° EMI shield solution. Receptacle kits are mainly composed of a 360° backshell and the RJF PCB receptacle with 8 tinned holes for solder termination. With those receptacle kits provided without cable, you will have to solder your cable on the PCB. The plug kit is composed with the 360° backshell where you will have to include your own RJ45 cordset. You can find below, wires and shielding wire cabling specification.

We recommend to use our reinforced Ethernet cables. If you prefer to use your own cable, please check with us compatibility.

In case you would like to receive a complete 360° EMI shield receptacle already mounted with a specific length of cable, please consult us.

## Overall dimension

### Plug - Shell type 6 - Straight 360° EMI backshell

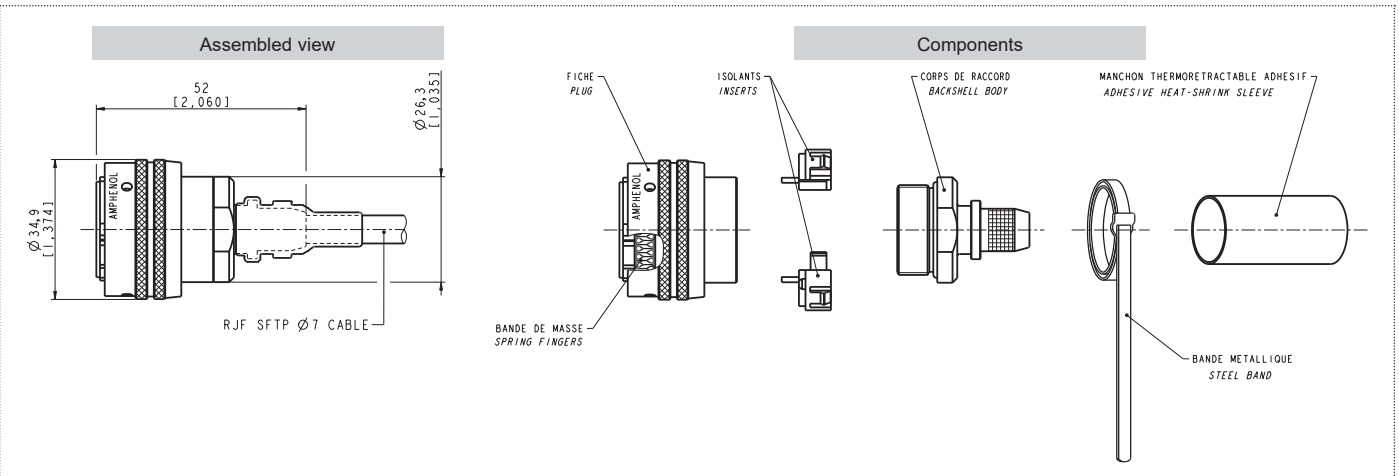

### Receptacle - Square flange receptacle - 4 mounting holes - Shell type 2 - Straight 360° EMI backshell

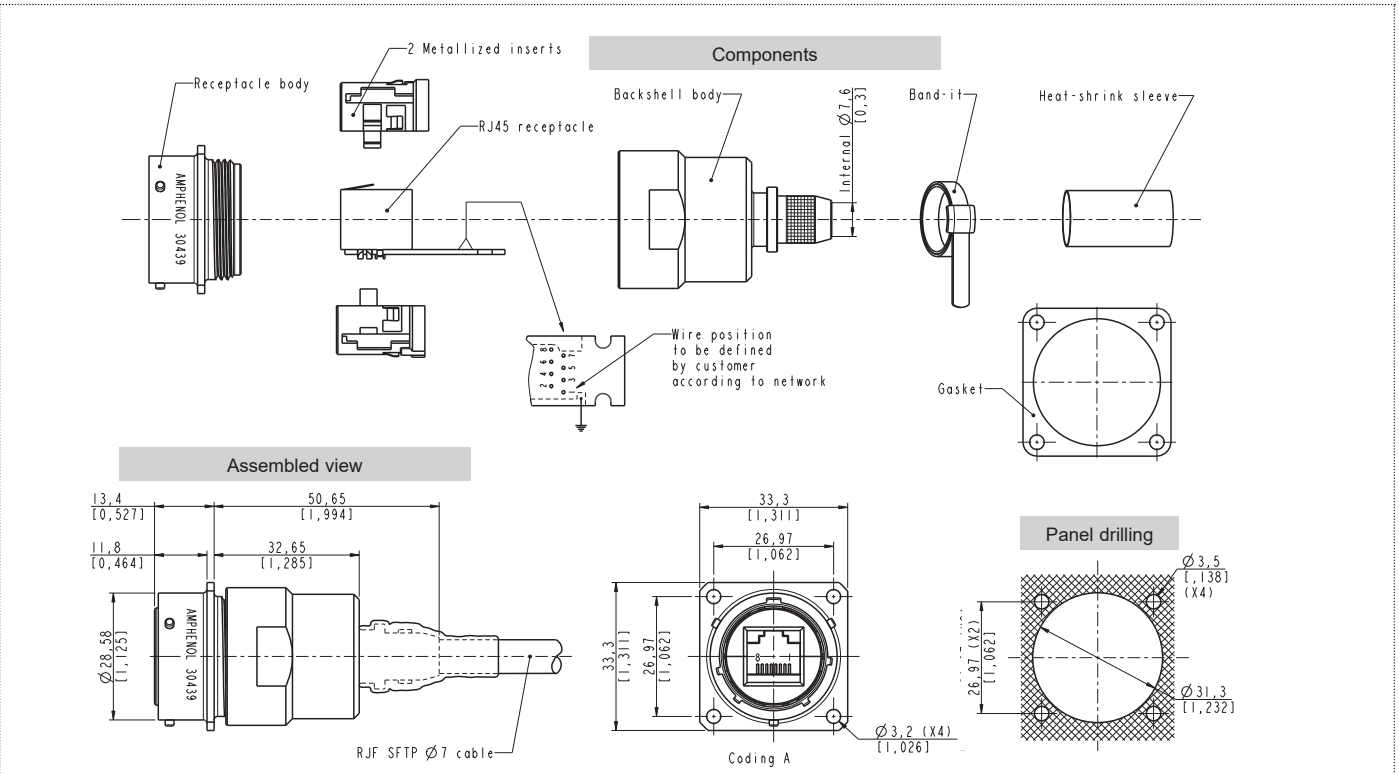

# RJF™ - PLUG AND RECEPTACLE WITH 360° EMI BACKSHELL

## Overall dimension

Receptacle - Jam nut receptacle - Hexagonal nut mounting - Shell type 7 - Straight 360° EMI backshell

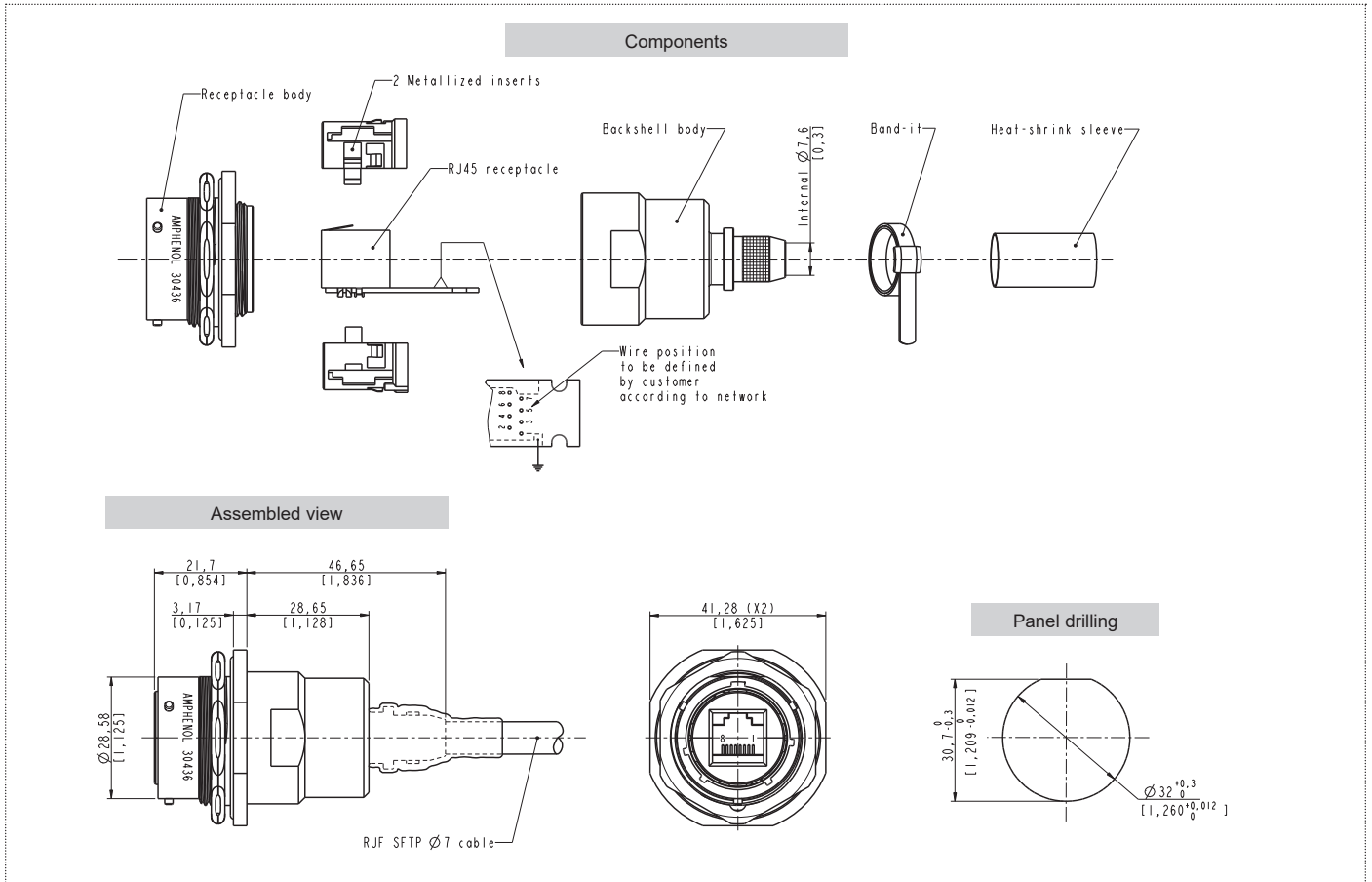

Data transmission	Part number	Shell type	Plating
Cat.5e	KIT30394N	Plug	Nickel ✓
	KIT30394		Olive drab cadmium
	KIT30394ZN		Black zinc nickel ✓
	KIT30439N		Nickel ✓
	KIT30439	Square flange receptacle	Olive drab cadmium
	KIT30439ZN		Black zinc nickel ✓
	KIT30436N		Nickel ✓
	KIT30436		Jam nut receptacle
KIT30436ZN	Black zinc nickel ✓		

✓ : RoHS compliant

**RJF™ - PLUG FOR BIG INSULATION WIRE UP TO 1.6 MM**

## Description

This RJF™ kit is composed of necessary components to assemble a RJF™ plug, particularly if you foresee to use a large ethernet cable. The plug kit is composed by a specific RJ45 Cat6A plug that should be crimped to the cable. The adhesive metal tape and the heat shrink boot provide a proper finish and a electrical insulation. Finally the RJStop included in this kit, is perfectly adapted to the RJ45 Cat6A plug.

## Main features

### MAIN CHARACTERISTICS

- Bayonet coupling ("Audible & Visual" coupling signal )
- Robust metallic shells based on MIL-DTL-26482 J - Shell size 18
- RJ45 cordset retention in the plug: 100 N in the axis
- Mating cycles: 500 min
- Sealed against fluids and dust (IP68)
- Shock, vibration and traction resistant
- Mechanical coding / polarization (4 positions)
- Compatible with cable diameter from 6 mm [0.216 in] to 13 mm [0.512 in], for smaller diameters, please consult us

### DATA TRANSMISSION

- 10 BaseT, 100 BaseTX and 1000 BaseT networks
- Cat.6A per TIA/EIA 568B and ClassEa per ISO/IEC 11801

### ENVIRONMENTAL PROTECTION

- Sealing: IP68
- Salt Spray:
  - 48 h with nickel plating over aluminium shell ✓
  - 96 h with black coating over aluminium shell ✓
  - 500 h black zinc nickel over aluminium shell ✓
  - 500 h with olive drab cadmium plating over aluminium shell
- Fire retardant/Low smoke: UL94 V0 and EN45545
- Vibrations: 10 – 500 Hz, 10 g, 3 axes: no discontinuity >10 nano s.
- Shocks: IK06 ► weight of 250 g drop from 40 cm [15.75 in] onto connectors (mated pair)
- Humidity: 21 days, 43°C, 98% humidity
- Temperature range: - 40°C / +85°C

### APPLICATIONS

- Battlefield communication systems
- C5ISR
- Data acquisition and transmission in harsh environment
- Optronics
- Navy
- Rail Mass Transit
- Industrial process control
- Robotics
- CNC machines
- Oil & Gas

✓ : RoHS compliant

# RJF™ - PLUG FOR BIG INSULATION WIRE UP TO 1.6 MM

## Overall dimension

Plug - Shell type 6 - Straight 360° EMI backshell

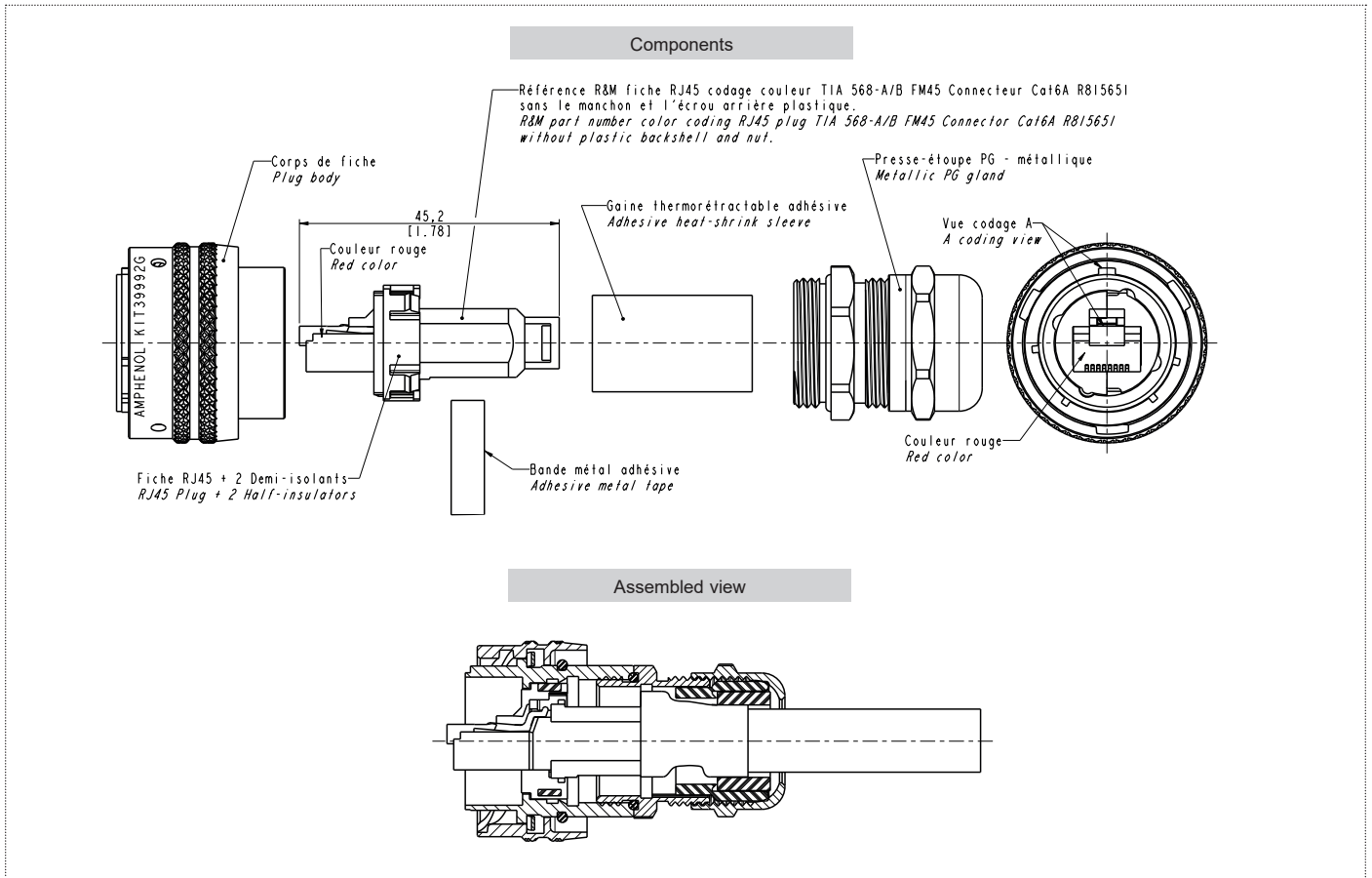

Data transmission	Part number	Plating
Cat.6A	<a href="#">KIT39992B</a>	Black coating ✓
	<a href="#">KIT39992NI</a>	Nickel ✓
	<a href="#">KIT39992G</a>	Olive drab cadmium
	<a href="#">KIT39992ZN</a>	Black Zinc Nickel

✓ : RoHS compliant

## RJ11F



## Description

RJ11F enables you to use a standard RJ11/12 cable and transform it into a ruggedized, bayonet coupling connector. Derived from MIL-DTL-26482 J with a shell size 14. The bayonet coupling is quick, audible and visual, facilitating the data transmission and acquisition in harsh environment.

This solution has several advantages. The assembly of your solutions is easily installed because you don't need any tool. You can choose between four different codings on the plug and receptacle side. With the help of the dedicated tool you can remove the insert of the receptacle in order to change the coding if needed. You can also use it for reparation or maintenance. Everything can be done in place.

## Main features

### MAIN CHARACTERISTICS

- Bayonet coupling ("Audible & Visual" coupling signal )
- Robust metallic shells based on MIL-DTL-26482 J
- 4 mechanical user-defined coding / Polarization settings (insert rotation)
- RJ11 cordset retention in the plug: 100 N in the axis
- Mating cycles: 500 min
- Compatible with cable diameter from 5 mm [0.0164 in] to 13 mm [0.0426 in]
- For smaller diameters, please consult us.

### ENVIRONMENTAL PROTECTION

- Sealing: IP68
- Salt Spray:
  - 48 h with nickel plating over aluminium shell ✓
  - 96 h with black coating over aluminium shell ✓
  - 500 h black zinc nickel over aluminium shell ✓
  - 500 h with olive drab cadmium plating over aluminium shell
- Fire Retardant / Low Smoke: UL94 V0 and EN45545
- Vibrations: 10 – 500 Hz, 10 g, 3 axes: no discontinuity > 10 nano s.
- Shocks: IK06: weight of 250 g drop from 40 cm [15.75 in] onto connectors (mated pair)
- Humidity: 21 days, 43°C, 98% humidity
- Temperature Range: - 40°C / +85°C

### APPLICATIONS

- Battlefield communication
- Industrial applications

**How to order :** Please refer to page 112

## Back terminations

**Type 1 :**  
Female RJ11

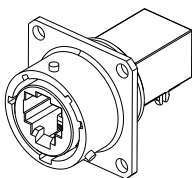

**Type 2 :**  
Solder - 8 tinned holes

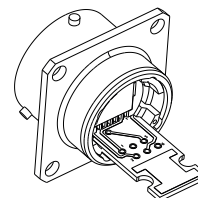

✓ : RoHS compliant

# RJ11F

## Overall dimension

Plug - Shell type 6 with plastic gland

Part number type : **RJ11F 6 X**

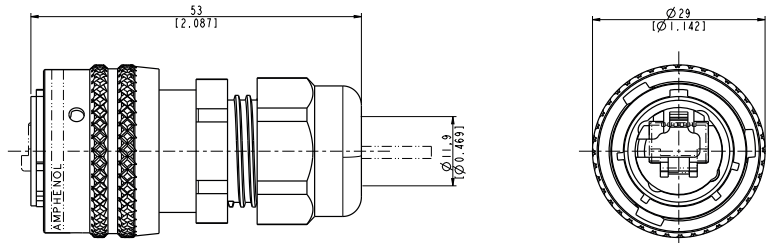

Receptacle - Square flange receptacle - 4 mounting holes - Shell type 2 - back termination type 1

Part number type : **RJ11F 2 1 X**

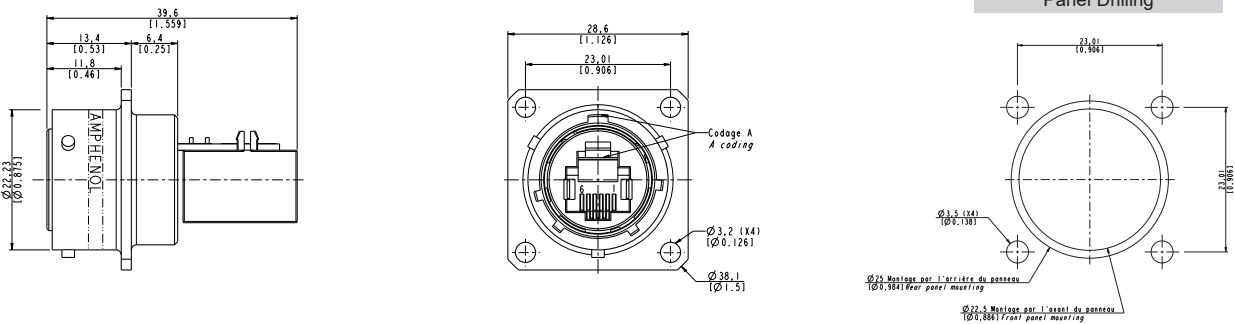

Receptacle - Jam nut receptacle - Hexagonal nut mounting - Shell type 7 - back termination type 1

Part number type : **RJ11F 7 1 X**

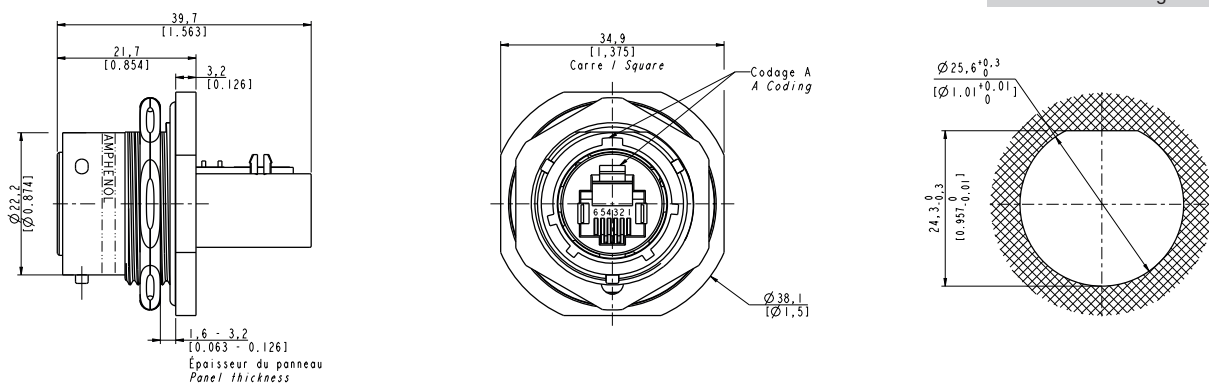

# RJ11F

## Overall dimension

Receptacle - Square flange receptacle - 4 mounting holes - Shell type 2 - back termination type 2

Part number type : **RJ11F 2 2 X**

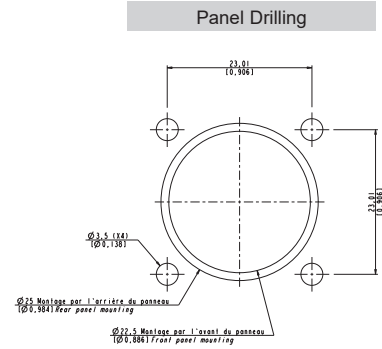
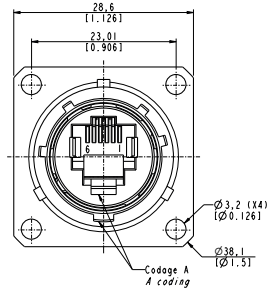
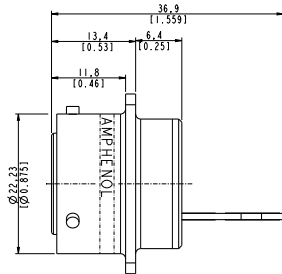

Receptacle - Jam nut receptacle - Hexagonal nut mounting - Shell type 7 - back termination type 2

Part number type : **RJ11F 7 2 X**

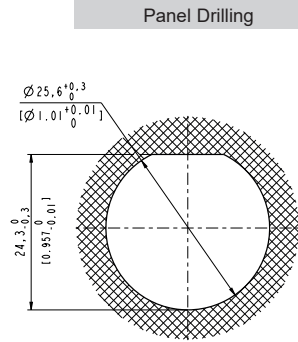
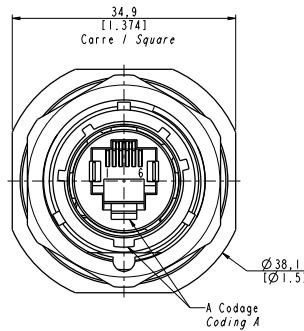
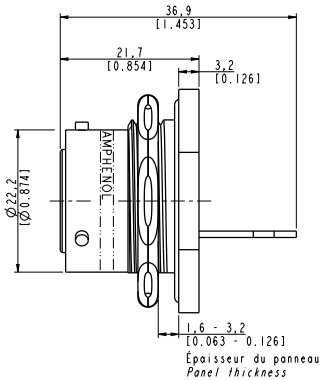

Sealed receptacle - Square flange receptacle - 4 mounting holes - Shell type 2 - back termination type 1

Part number type : **RJ11F 2 SA 1 X**

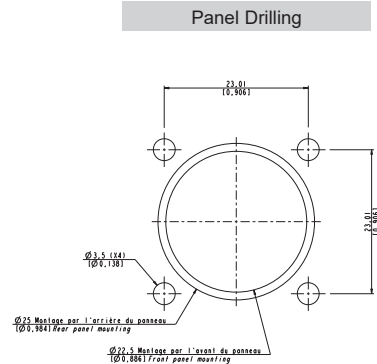
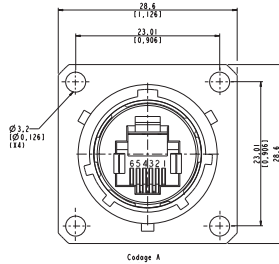
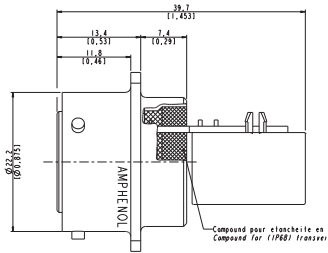

# RJ11F

## Overall dimension

Sealed receptacle - Jam nut receptacle - Hexagonal nut mounting - Shell type 7 - back termination type 1

Part number type : **RJ11F 7 SA 1 X**

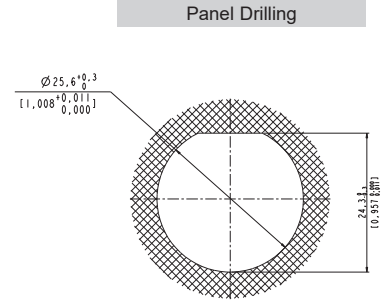
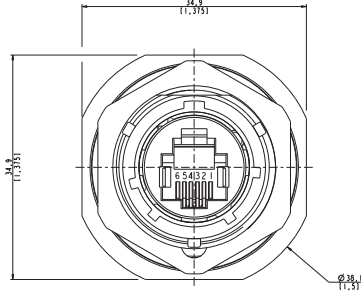
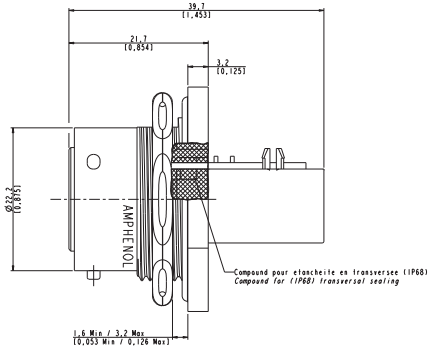

Sealed receptacle - Square flange receptacle - 4 mounting holes - Shell type 2 - back termination type 2

Part number type : **RJ11F 2 SA 2 X**

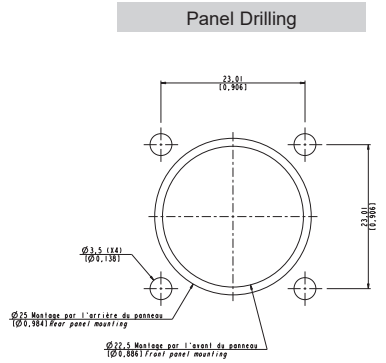
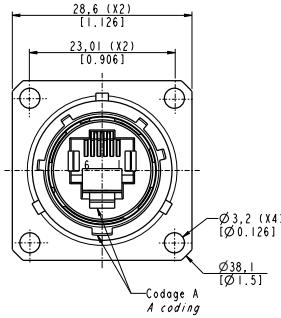
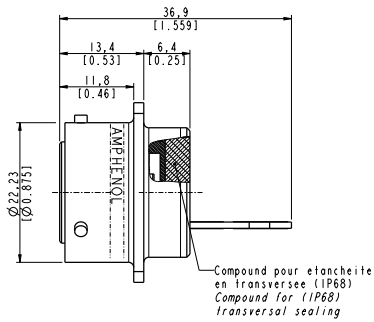

Sealed receptacle - Jam nut receptacle - Hexagonal nut mounting - Shell type 7 - back termination type 2

Part number type : **RJ11F 7 SA 2 X**

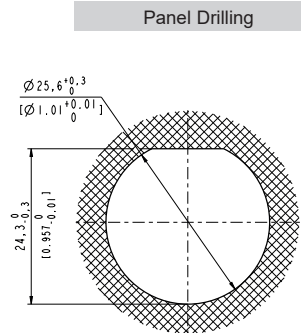
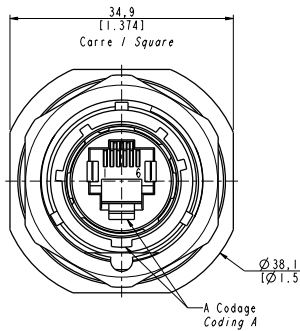
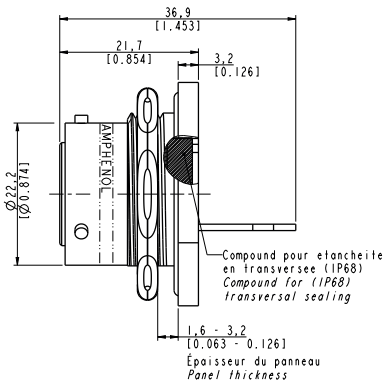



# RJ11F

## Overall dimension

Sealed Receptacle - Square flange receptacle - 4 mounting holes - Shell type 2 - PC tails

Part number type : **RJ11F 2 SA 5 X**

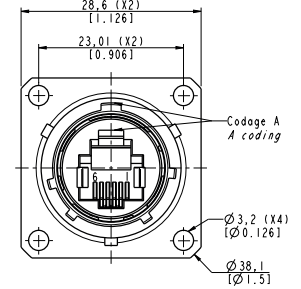
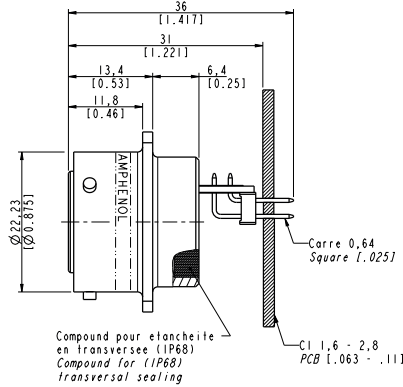
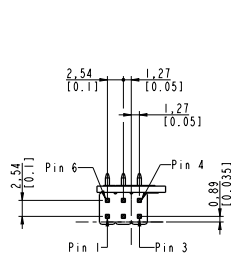

PCB Layout

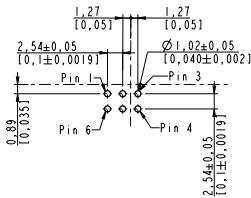

Panel Drilling

Perçages panneau (Épaisseur 2,5 Max Pour Montage par l'arrière)

Panel drilling (Thickness 0,098 Max for rear mounting)

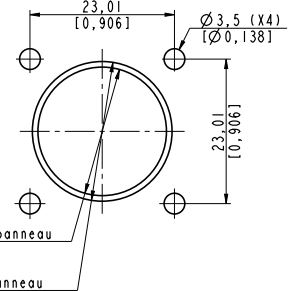

Ø22,5 Montage par l'avant du panneau [Ø0,886] Front panel mounting  
Ø25 Montage par l'arrière du panneau [Ø0,984] Rear panel mounting

Sealed Receptacle - Jam nut receptacle - Hexagonal nut mounting - Shell type 7 - PC tails

Part number type : **RJ11F 7 SA 5 X**

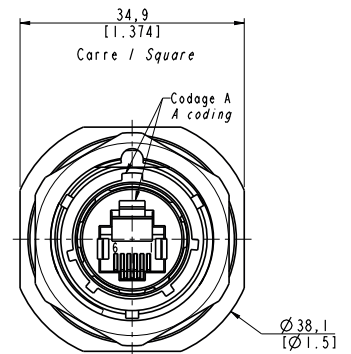
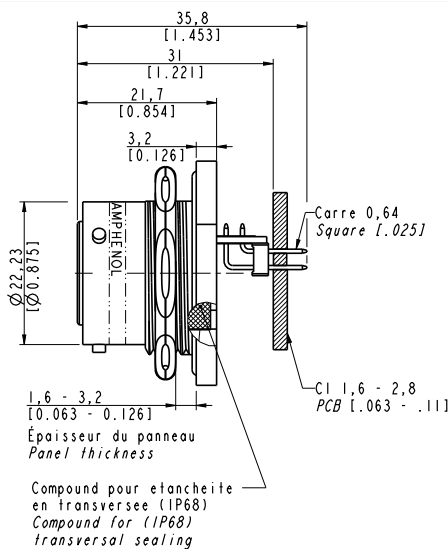
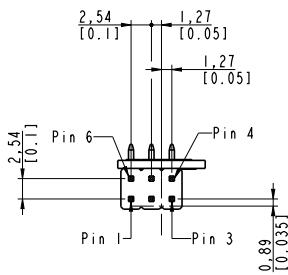

PCB Layout

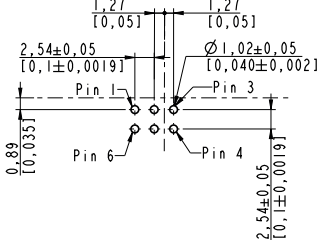

Panel Drilling

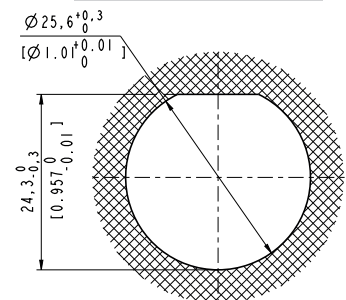



## Description

The RJFTV™ is our main standard derived from MIL-DTL-38999 series III with a shell size 19. This tri-start thread coupling mechanism is the most resistant of all against shock or vibration, perfectly suitable for all transmission in harsh environment.

This solution has several advantages. The assembly of your solutions is easily installed because you don't need any tool, thanks to the patented RJStop system. You can choose between four different codings on the plug and receptacle side. With the help of the dedicated tool you will be able to remove the insert of the receptacle in order to change the coding if needed. You can also use it for reparation or maintenance. Everything can be done in place. The complete solution is metallized and united when connected in order to transmit the electrical continuity from cordset to the panel.

The following pages list all complementary configurations that you could need on your system such as sealed and hermetic receptacles, 360° EMI solutions for reinforced shielding or whether special plugs for big insulations wire.

## Main features

### MAIN CHARACTERISTICS

- Tri Start Thread coupling mechanism (MIL-DTL-38999 series III type) with anti-decoupling device - Shell size 19
- Sealed against fluids and dusts (IP68)
- Shock, vibration and traction resistant
- No cabling operation in field and no tools required
- Mechanical coding / Polarization (4 positions)
- Improved EMI protection
- Robust metallic shells
- RJ45 cordset retention in the plug: 100 N in the axis
- Mating cycles: 500 min
- Compatible with cable diameter from 6 mm [0.236 in] to 12 mm [0.472 in], for smaller diameters please consult us

### ENVIRONMENTAL PROTECTION

- Sealing: IP68
- Salt spray:
  - 48 h with nickel plating over aluminium shell ✓
  - 500 h black zinc nickel plating over aluminium shell ✓
  - 500 h with olive drab cadmium plating over aluminium shell
  - 500 h with marine bronze shell ✓
- Fire retardant/Low smoke : UL94 V0 and EN45545
- Vibrations : 10 - 500 Hz, 10 g, 3 axes: no discontinuity > 10 nano s.
- Compounded versions tested per NAS 1599 (5-3000 Hz, 20g, 12h)
- Shocks: IK06 ► weight of 250 g drop from 40 cm [15.75 in] onto connectors (mated pair)
- Humidity: 21 days, 43°C, 98% humidity
- Temperature range: -40°C / +85°C
- Panel thickness: 1,57 mm min and 3,18 mm max for jam nut receptacle

### DATA TRANSMISSION

- 10 BaseT, 100 BaseTX and 1000 BaseT networks
- Cat 5e per TIA/EIA 568B and ClassD per ISO/IEC 11801
- Cat.6 per TIA/EIA 568B and ClassE per ISO/IEC 11801
- Cat.6A per TIA/EIA 568B and ClassEa per ISO/IEC 11801

### APPLICATIONS

- Battlefield communication systems
- C5ISR
- Data acquisition and transmission in harsh environment
- Navy
- Rail Mass Transit
- Industrial process control
- Robotics
- CNC machines
- Oil & Gas

**How to order :** Please refer to page 113

✓ : RoHS compliant

## Back terminations

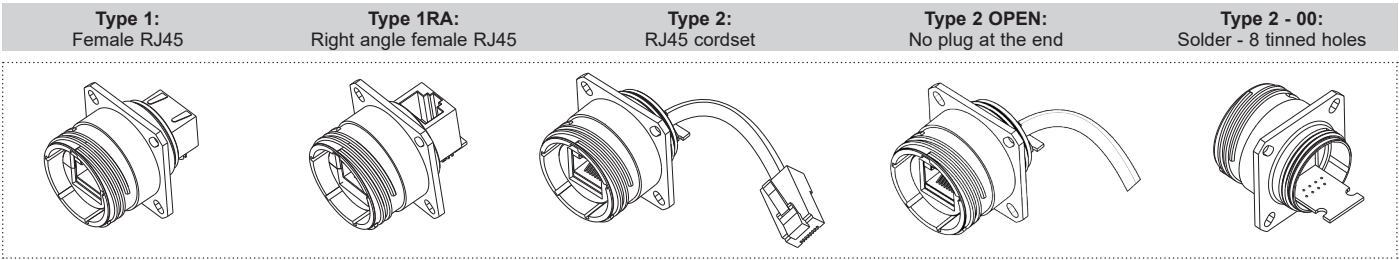

## Overall dimension

### Plug - Shell type 6 - Plastic gland

Part number type : **RJFTV 6 X**

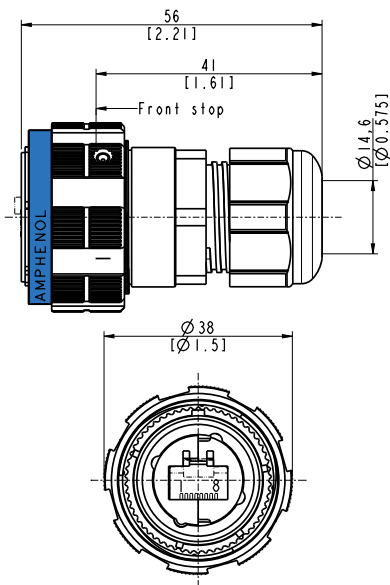

#### Components

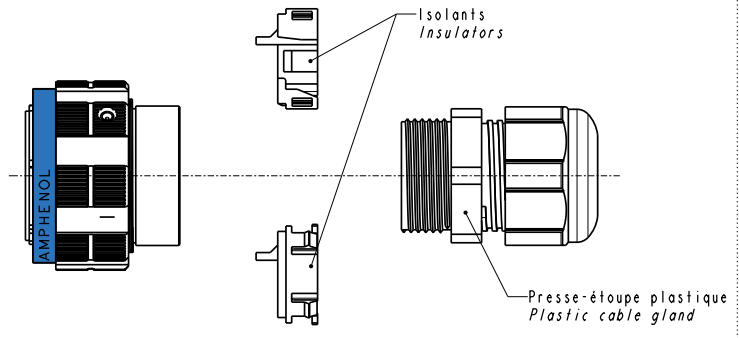

### Plug - Shell type 6 - Metal gland

Part number type : **RJFTV 6M X**

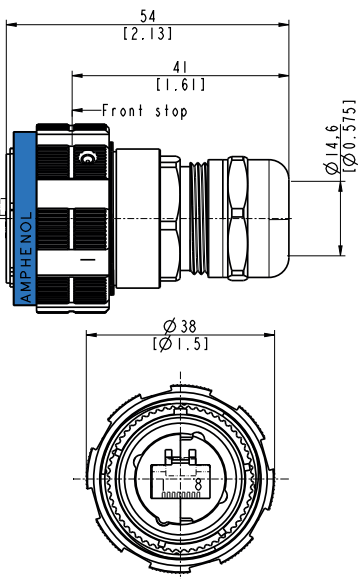

#### Components

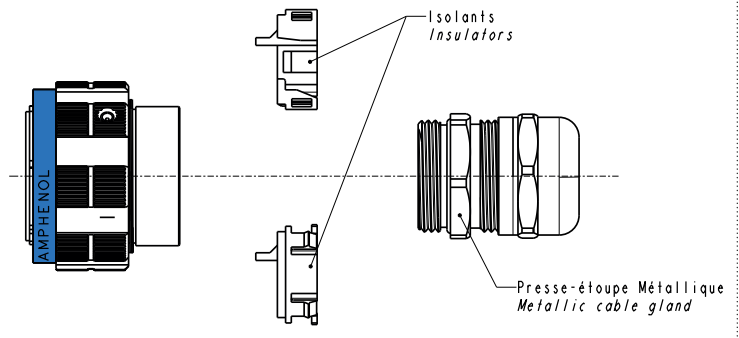

# Overall dimension

## Receptacle - Square flange receptacle - 4 mounting holes - Shell type 2 - back termination type 1

Part number type (Cat.5e) : **RJFTV 2 1 X**  
 Part number type (Cat.6) : **RJFTV 6 2 X 1 X**

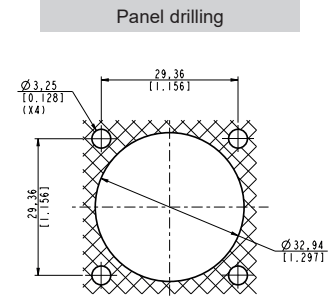
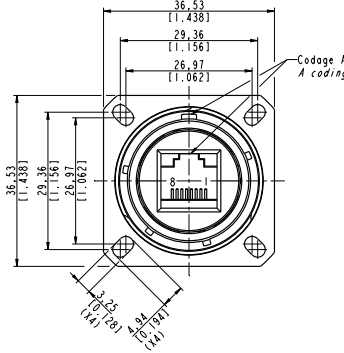
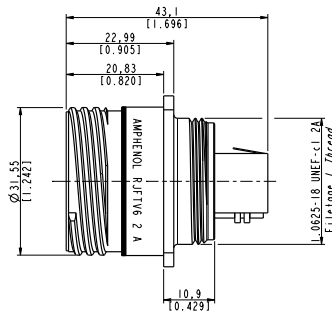

Part number type (Cat.6A) : **RJFTV 6A 2 X 1 X**

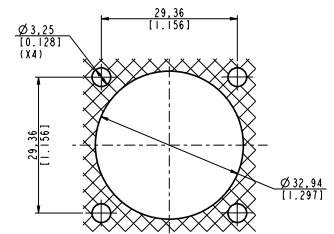
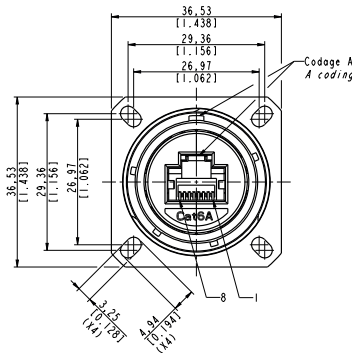
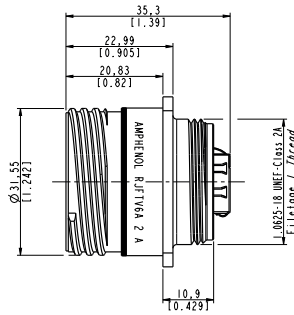

## Receptacle - Square flange receptacle - 4 mounting holes - Shell type 2 - back termination type 1RA

Part number type (Cat.5e) : **RJFTV 2 1RA X**

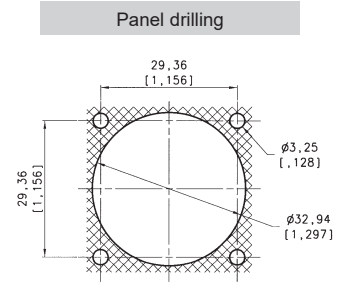
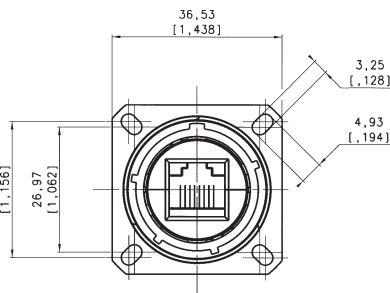
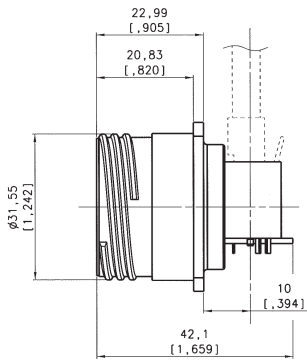

Part number type (Cat.6A) : **RJFTV 6A 2 X 1RA X**

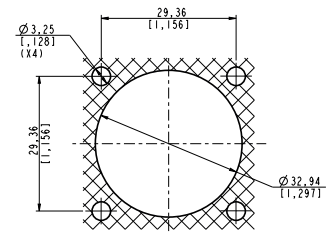
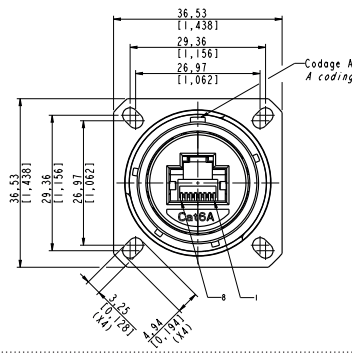
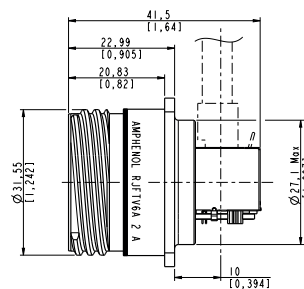

## Overall dimension

### Receptacle - Square flange receptacle - 4 mounting holes - Shell type 2 - back termination type 2

Part number type (Cat.5e) : **RJFTV 2 2 X XX 100BTX**

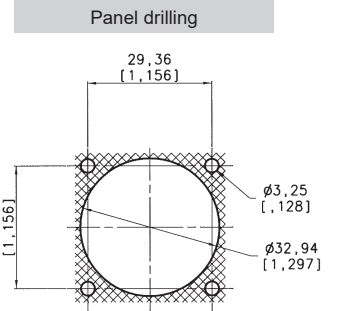
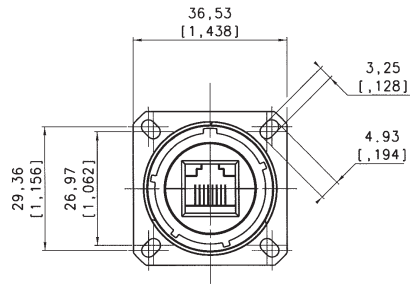
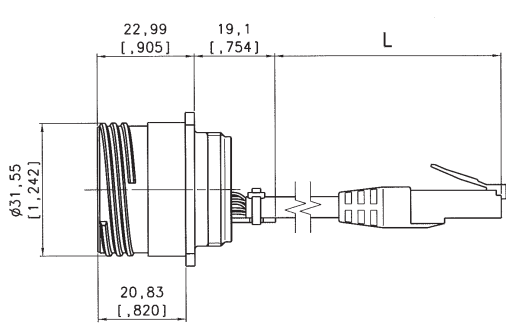

Part number type (Cat.5e) : **RJFTV 2 2 X XX OPEN**

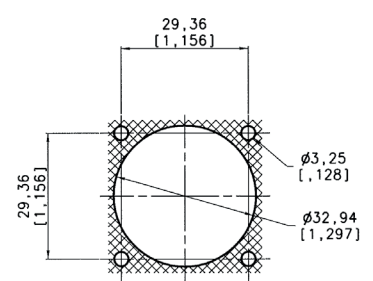
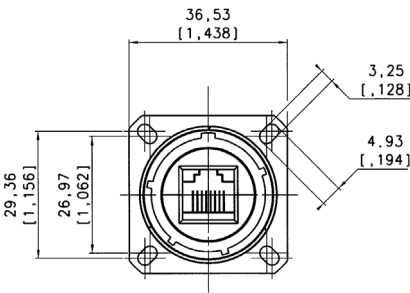
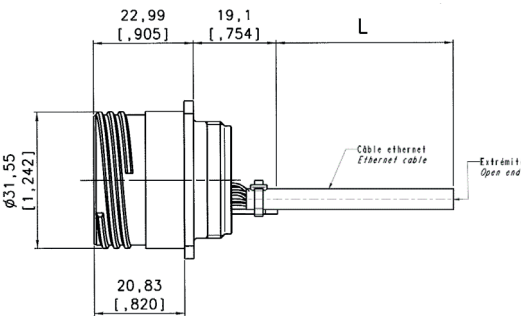

Part number type (Cat.5e) : **RJFTV 2 2 X 00**

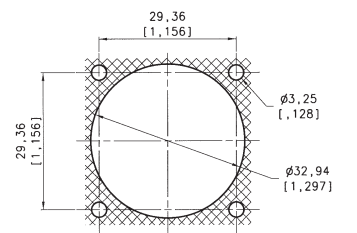
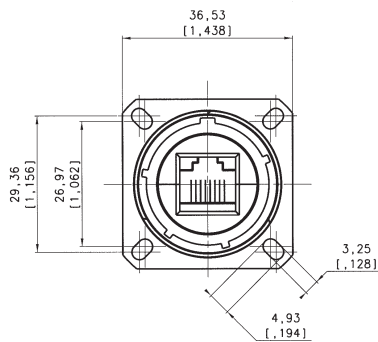
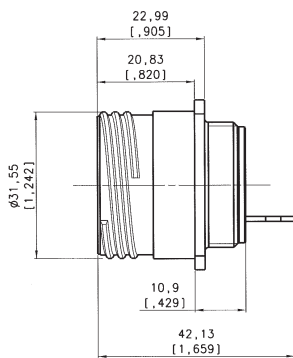

## Overall dimension

### Receptacle - Jam nut receptacle – Hexagonal nut mounting - Shell type 7 – back termination type 1

Part number type (Cat.5e): **RJFTV 7 1 X**  
 Part number type (Cat.6): **RJFTV 6 7 X 1 X**

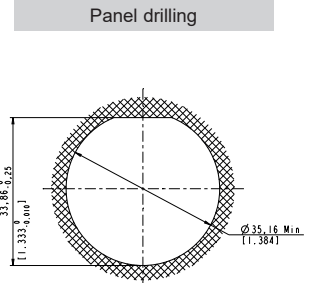
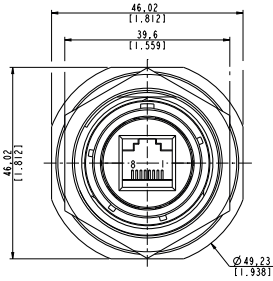
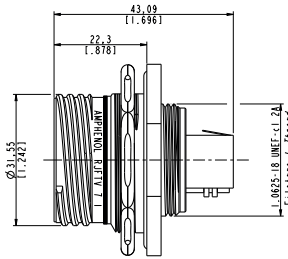

Part number type (Cat.6A) : **RJFTV 6A 7 X 1 X**

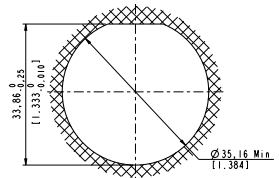
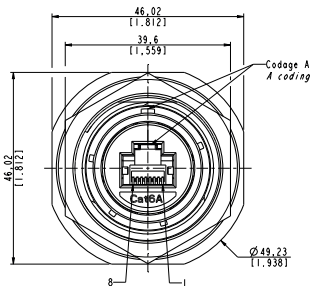
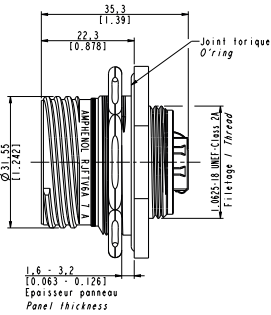

### Receptacle - Jam nut receptacle – Hexagonal nut mounting - Shell type 7 – back termination type 1RA

Part number type (Cat.5e) : **RJFTV 7 1RA X**

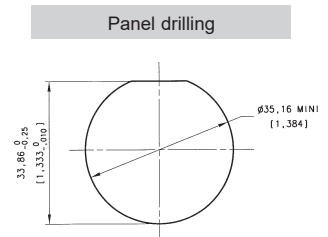
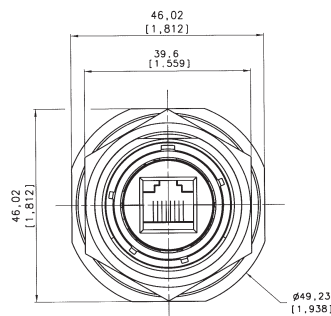
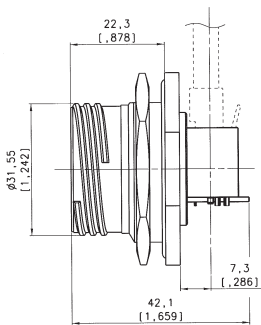

Part number type (Cat.6A) : **RJFTV 6A 7 X 1RA X**

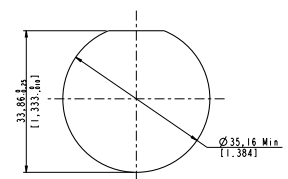
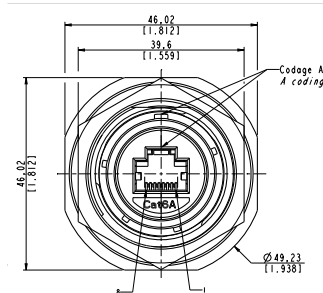
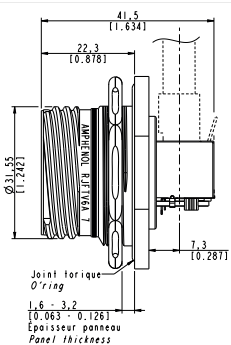

## Overall dimension

**Receptacle** - Jam nut receptacle – Hexagonal nut mounting - Shell type 7 – back termination type 2

Part number type (Cat.5e) : **RJFTV 7 2 X XX 100BTX**

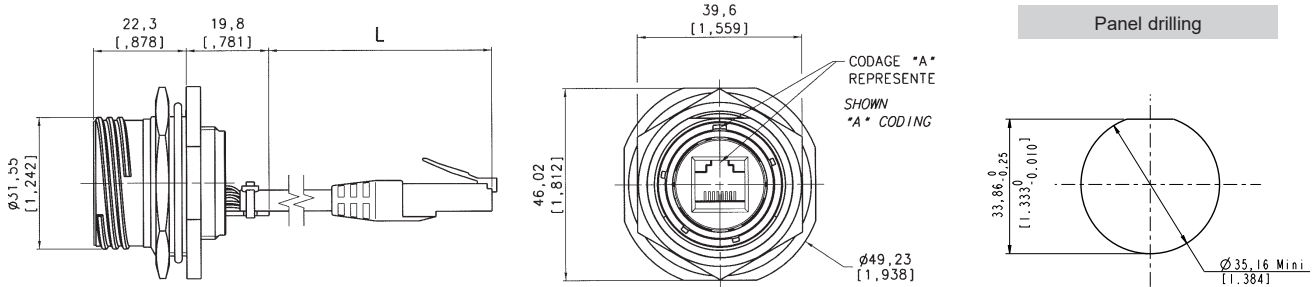

Part number type (Cat.5e) : **RJFTV 7 2 X XX OPEN**

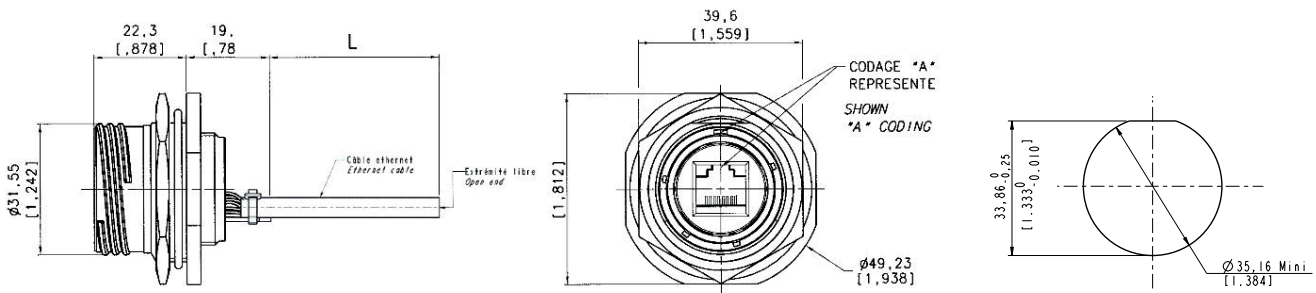

Part number type (Cat.5e) : **RJFTV 7 2 X 00**

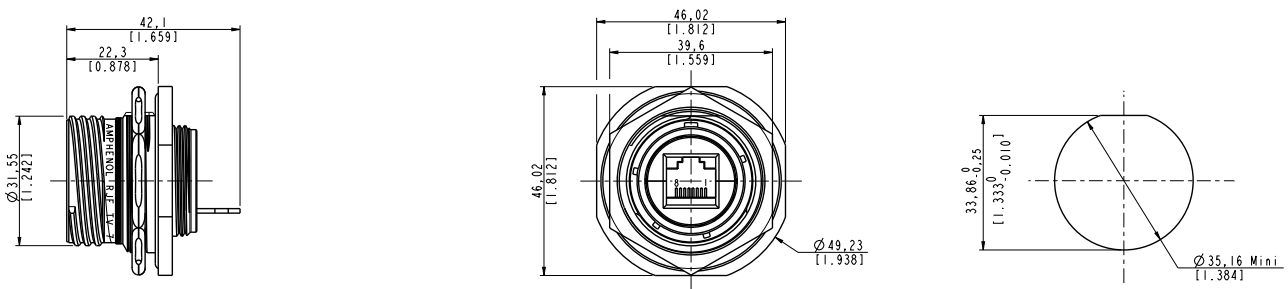

## Overall dimension

**Receptacle - Square flange receptacle - 4 mounting holes - Shell type 2 - Backshell with plastic gland**

Part number type (Cat.5e) : **RJFTV 2 PE X**  
 Part number type (Cat.6) : **RJFTV 6 2 X PE 1 X**

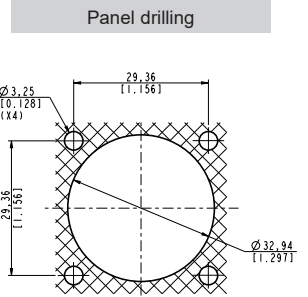
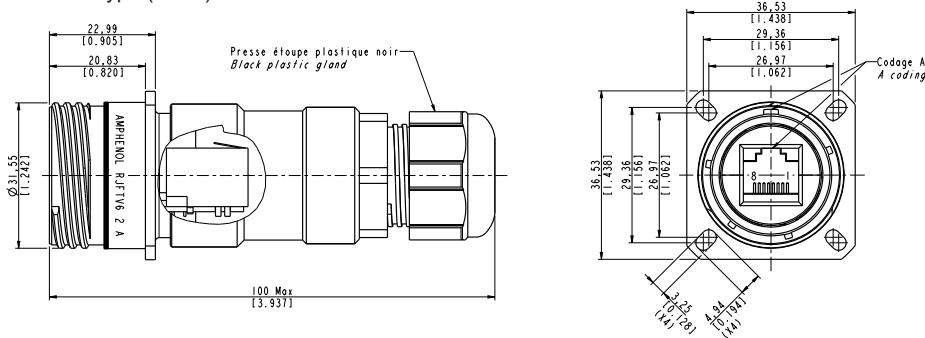

Part number type (Cat.6A) : **RJFTV 6A 2 X PE 1 X**

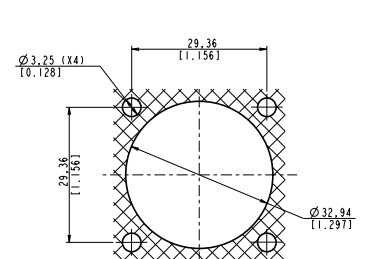
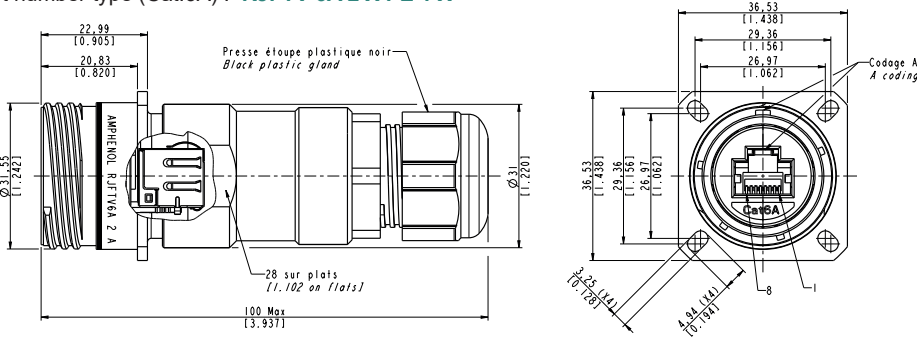

**Receptacle - Square flange receptacle - 4 mounting holes - Shell type 2 - Backshell with metal gland**

Part number type (Cat.5e) : **RJFTV 2 PEM 1 X**  
 Part number type (Cat.6) : **RJFTV 6 2 X PEM 1 X**

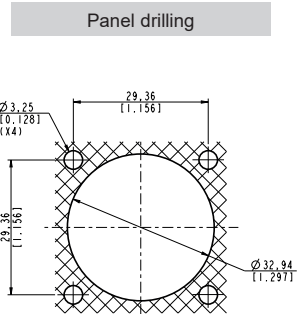
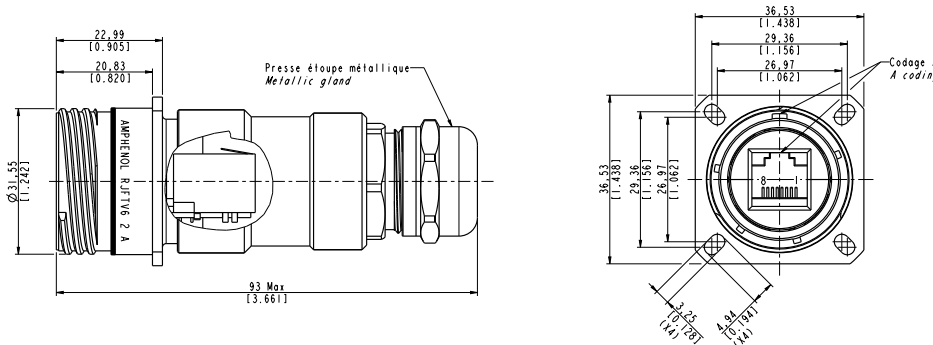

Part number type (Cat.6A) : **RJFTV 6A 2 X PEM 1 X**

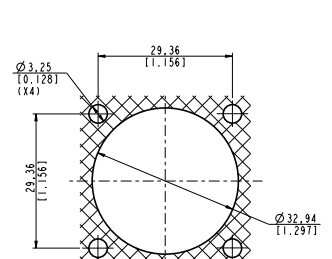
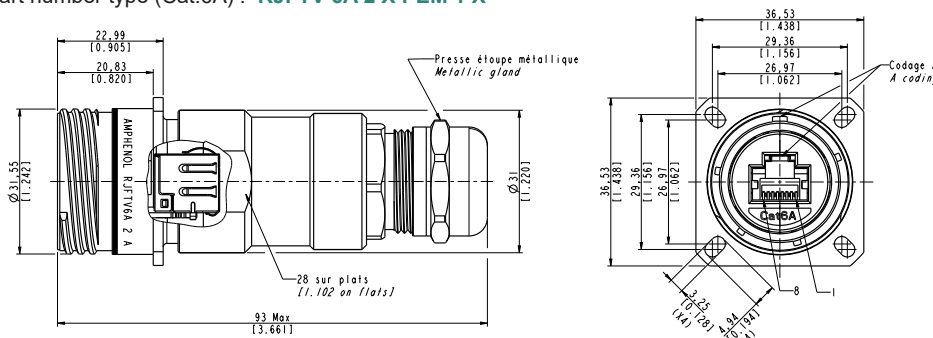



## Overall dimension

Receptacle - Jam nut receptacle - Hexagonal nut mounting - Shell type 7 - Backshell with plastic gland

Part number type (Cat.5e) : **RJFTV 7 PE X**  
 Part number type (Cat.6) : **RJFTV 6 7 X PE 1 X**

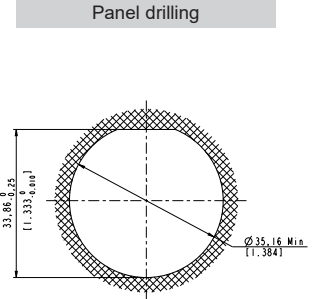
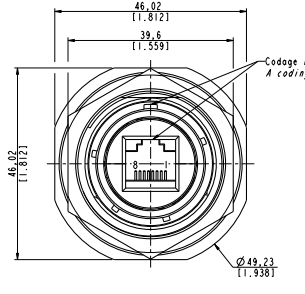
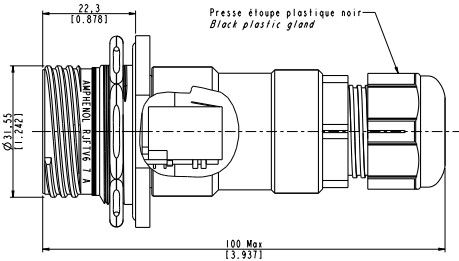

Part number type (Cat.6A) : **RJFTV 6A 7 X PE 1 X**

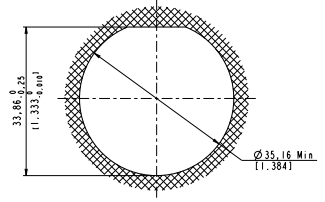
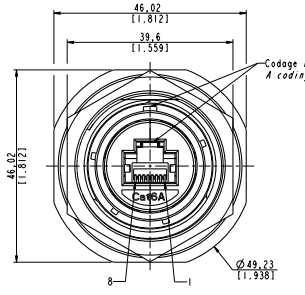
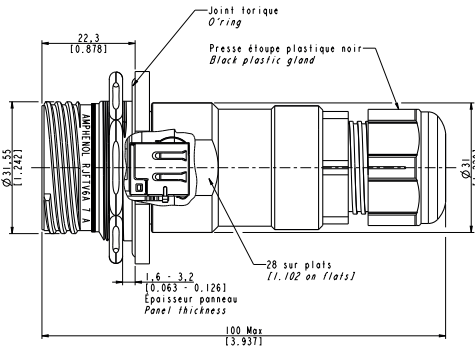

Receptacle - Jam nut receptacle - Hexagonal nut mounting - Shell type 7 - Backshell with metal gland

Part number type (Cat.5e) : **RJFTV 7 PEM 1 X**  
 Part number type (Cat.6) : **RJFTV 6 7 X PEM 1 X**

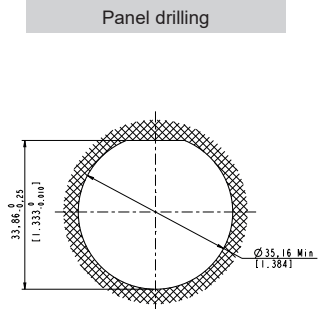
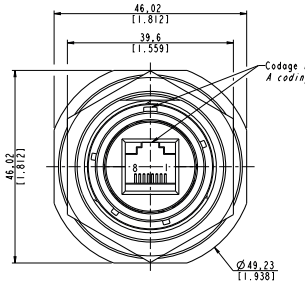
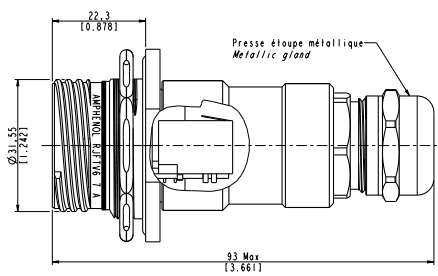

Part number type (Cat.6A) : **RJFTV 6A 7 X PEM 1 X**

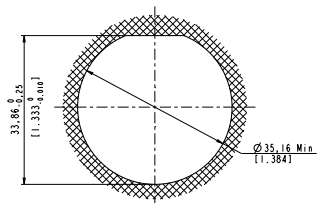
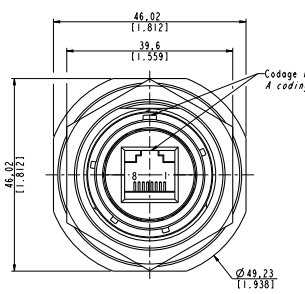
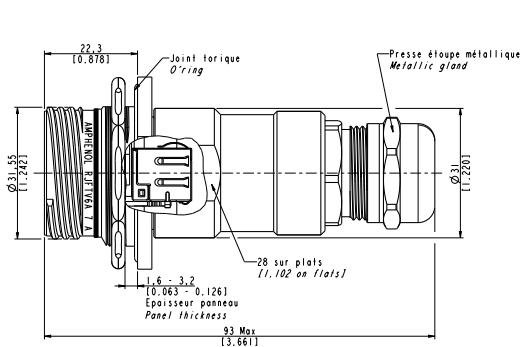

## Overall dimension

Receptacle - In line receptacle - Without flange - Metal gland

Part number type (Cat.5e) : **RJFTV 2 PEM WF 1 X**

Part number type (Cat.6) : **RJFTV 6 2 PEM WF 1 X**

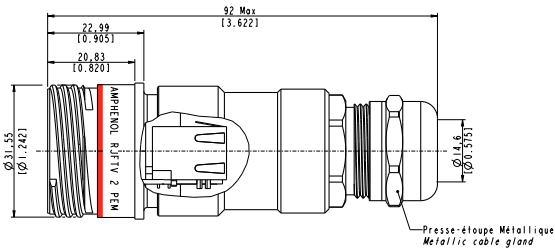

Part number type (Cat.6A) : **RJFTV 6A 2 PEM WF 1 X**

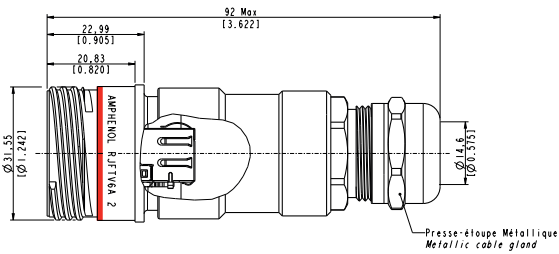

Metal range

Composite range

Cables and cordsets

Adaptors and access points

Accessories

Assembly instructions

How to order

# RJFTV™ - TRANSVERSALLY SEALED AND HERMETIC RECEPTACLE



## Description

The transversally sealed receptacle is in all aspects equivalent to the standard and in addition, is improved with compound at the rear of the receptacle. This will prevent the sealing of the receptacle when unmated with its plug or protective cap.

The hermetic solution, as the transversally sealed one, is compounded at the rear of the receptacle. Helium leakage is less than  $1.10^{-6}$  cm<sup>3</sup> per second [0.1 micron cubit ft per hour] at one bar [15 psi] pressure differential. The test is 100% done on all of these hermetic receptacles.

## Main features

### MAIN CHARACTERISTICS

- Same as the RJFTV™ series.
- A complete IP68 sealing of the receptacle (even with no plug or no protective cap mated) is added.
- Outside dimensions are the same as the standard RJFTV series.
- Vibrations: the compounded versions of the RJFTV have been tested in vibration following the NAS 1599 Aeronautic specification (Ambient temperature):  
5 - 3000 Hz, 20g, 2,5 mm [.1 inch] double amplitude, 3 axes, 12 hours

### DATA TRANSMISSION

- 10 BaseT, 100 BaseTX and 1000 BaseT networks
- Cat 5e per TIA/EIA 568B and ClassD per ISO/IEC 11801
- Cat.6 per TIA/EIA 568B and ClassE per ISO/IEC 11801
- Cat.6A per TIA/EIA 568B and ClassEa per ISO/IEC 11801

### APPLICATIONS

- Battlefield communication systems
- C5ISR
- Data acquisition and transmission in harsh environment
- Optronics
- Navy
- Rail Mass Transit
- Industrial process control
- Robotics
- CNC machines
- Oil & Gas

### Important note:

- Due to the compound, the coding orientation has to be define in the reference.
- To choose your coding orientation, please refer to "Assembly instructions" page 104.

**How to order :** Please refer to page 114

# RJFTV™ - STAND-OFF RECEPTACLE



## Description

This enhanced design allows you to mount the connector shell directly on PC board. Soldering your contacts directly on the board will help to save you a lot of space inside of your system. As the double-flange of this connector is directly fixed on the board, mechanical stresses are absorbed by the shell and not the contacts. In addition to this benefit, the sealing is improved by the compounded receptacle.

**How to order :** Please refer to page 115

## Overall dimension

Receptacle - Square flange receptacle - 4 mounting holes - Shell type 2 - F459

Part number type (Cat.5e) : **36542X**

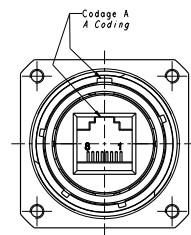
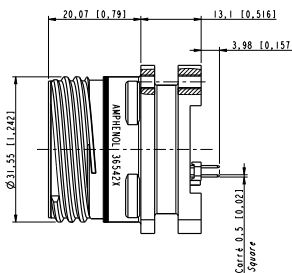
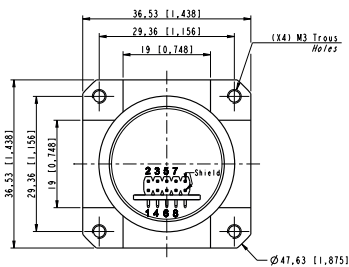

PCB Layout

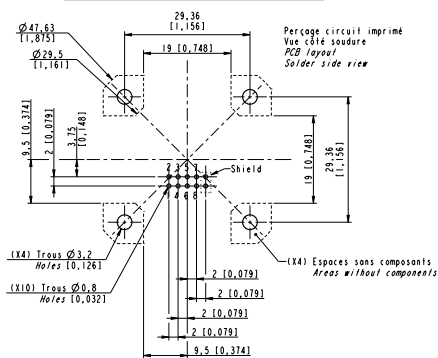

Panel drilling

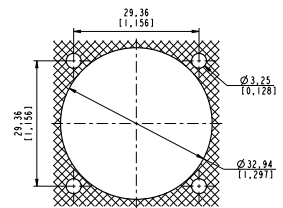

Part number type (Cat.6A) : **RJFTV 6A 2S X 5 X F459**

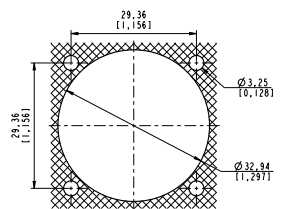
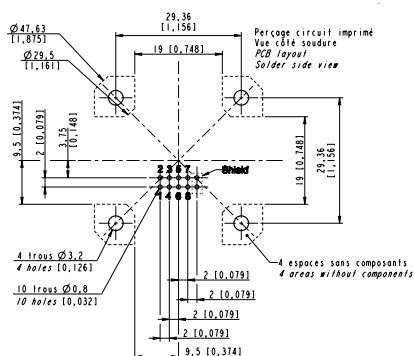
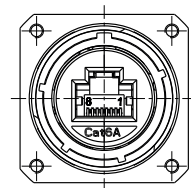
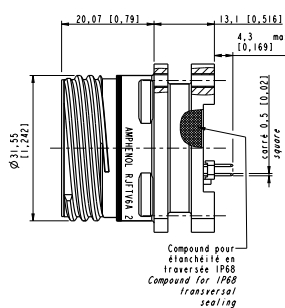
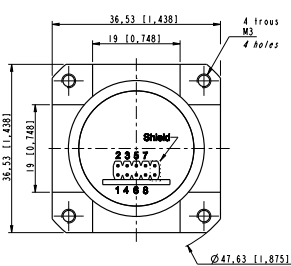

### Important note:

- Due to the compound, the coding orientation has to be define in the reference.
- To choose your coding orientation, please refer to "Assembly instructions" page 104

✓ : RoHS compliant

# RJFTV™ - STAND-OFF RECEPTACLE

## Overall dimension

Receptacle - Jam nut receptacle - Hexagonal nut mounting - Shell type 7 - F459

Part number type (Cat.5e) : **36540X**

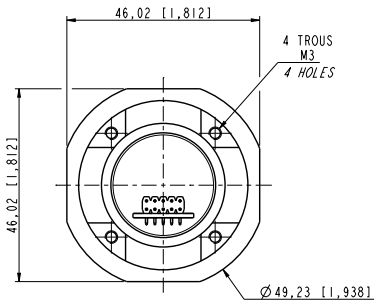

PCB Layout

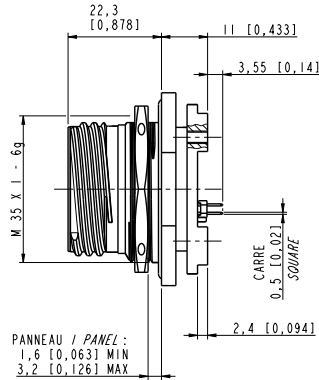

PANNEAU / PANEL :  
1,6 [0,063] MIN  
3,2 [0,126] MAX

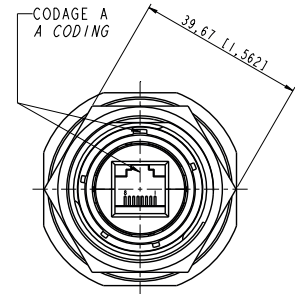

Panel drilling

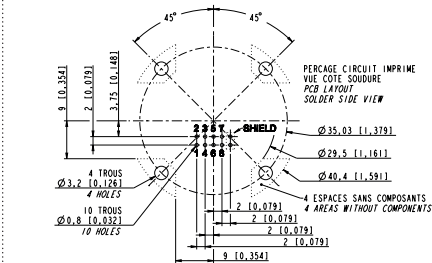

Part number type (Cat.6A) : **RJFTV 6A 7S X 5 X F459**

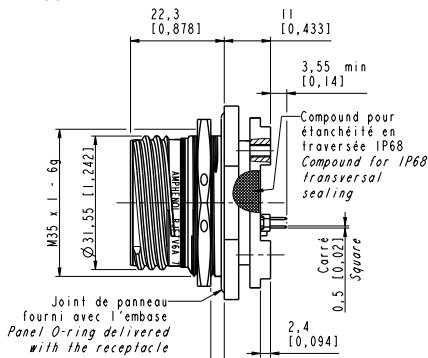
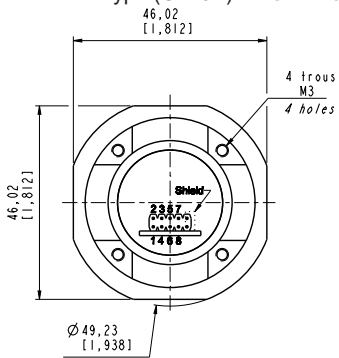

Joint de panneau  
fourni avec l'embase  
Panel O-ring delivered  
with the receptacle

Panneau / Panel  
1,6 [0,063] min  
3,2 [0,126] max

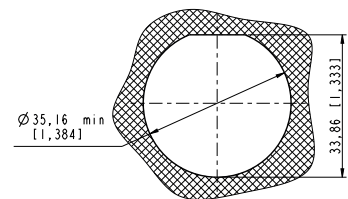
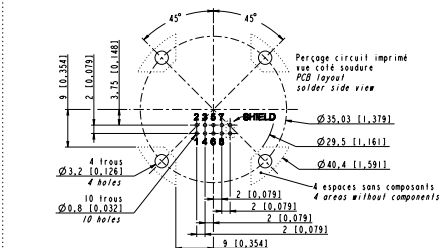
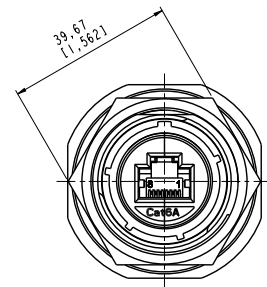

**Important note:**

- Due to the compound, the coding orientation has to be define in the reference.
- To choose your coding orientation, please refer to "Assembly instructions" page 104

✓ : RoHS compliant

# RJFTV™ - REDUCED FLANGE RECEPTACLE



## Description

Derived from standard RJFTV™, Reduced Flange RJFTV™ is ideal for applications where small dimensions and lower weight are critical in harsh environments. The reduced flange deviation saves 41% footprint surface reduction and is 15% lighter than standard RJFTV™ receptacle. RJFTV™ Reduced flange receptacle is available in Cat5.e, Cat.6 and Cat6A. Moreover, you have two castle nut options, standard castle nut and safety castle nut that enables you to add a lock wire for anti-rotation of the nut.

**How to order :** Please refer to page 116

## Overall dimension

**Receptacle - Reduced flange Jam nut receptacle - Castle nut mounting - Shell type 7 - F312 or F311**

- Part number type (Cat.5e) : **RJFTV 7 1 X F312**  
**RJFTV 7 1 X F311**
- Part number type (Cat.6) : **RJFTV 6 7 X 1 X F312**  
**RJFTV 6 7 X 1 X F311**

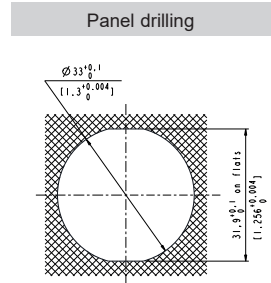
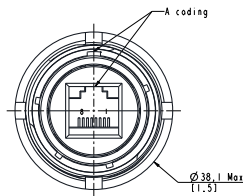
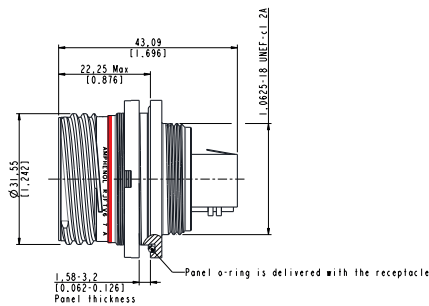

- Part number type (Cat.6A) : **RJFTV 6A 7 X 1 X F312**  
**RJFTV 6A 7 X 1 X F311**

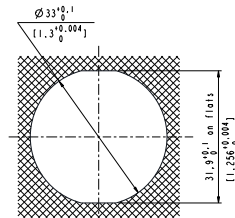
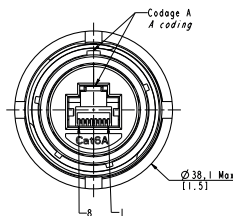
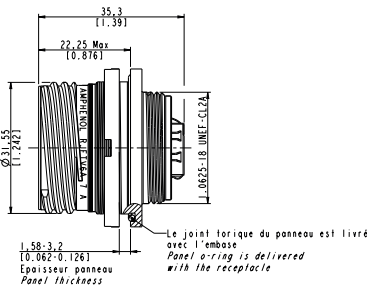

**Important note:**

- To choose your coding orientation, please refer to "Assembly instructions" page 104

✓ : RoHS compliant

# RJFTV™ - REDUCED FLANGE RECEPTACLE

## Overall dimension

Receptacle - Reduced flange Jam nut receptacle - Castle nut mounting - Shell type 7 - F059 or F058

Part number type (Cat.5e) : **RJFTV 7S X 5 X F059**

**RJFTV 7S X 5 X F058**

Part number type (Cat.6) : **RJFTV 6 7S X 5 X F059**

**RJFTV 6 7S X 5 X F058**

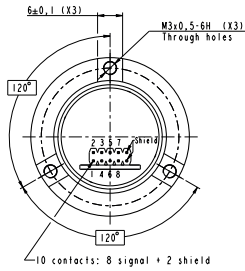

Coding A

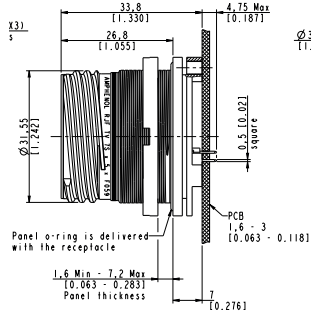

Coding B

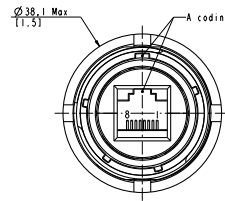

Coding C

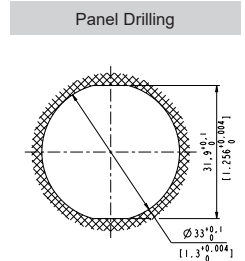

Coding D

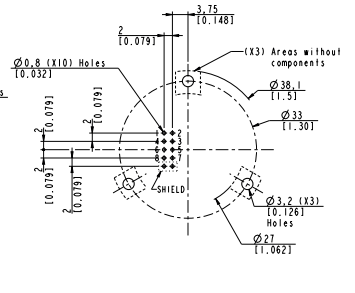
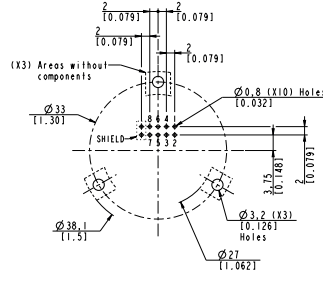
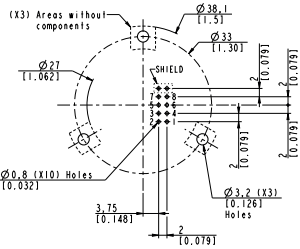
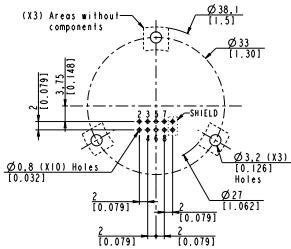

Part number type (Cat.6A) : **RJFTV 6A 7S X 5 X F059**

**RJFTV 6A 7S X 5 X F058**

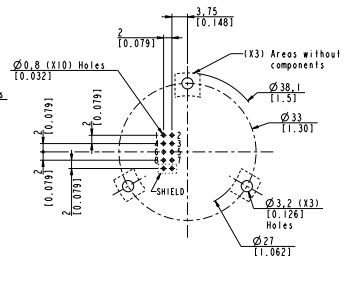
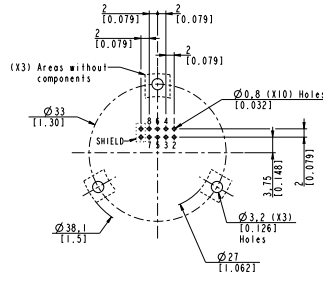
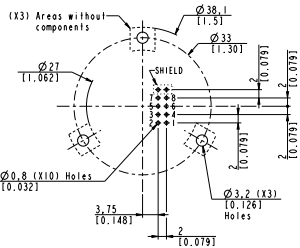
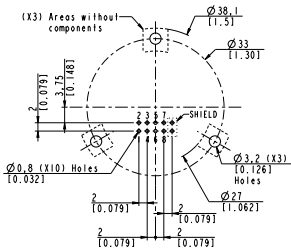
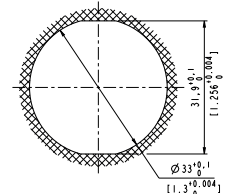
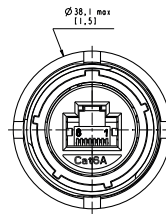
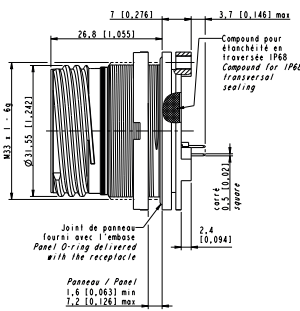
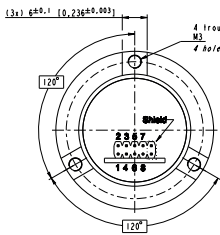

**Important note:**

- Due to the compound, the coding orientation has to be define in the reference.
- To choose your coding orientation, please refer to "Assembly instructions" page 104

✓ : RoHS compliant

# RJFTV™ - THROUGH-BULKHEAD RECEPTACLE



## Description

The RJFTV™ Through-bulkhead is a double-ended receptacle that enables you to connect two RJFTV™ plug on both side of your panel. In your system, it provides you the best protection and remains very easy to assemble.

**How to order :** Please refer to page 117

## Overall dimension

Receptacle - Square flange receptacle - 4 mounting holes - Shell type 2 - Trough-bulkhead

Part number type (Cat.5e) : **RJFTV B 2 X ISO XXX**  
 Part number type (Cat.6) : **RJFTV 6 B 2 X ISO XXX**

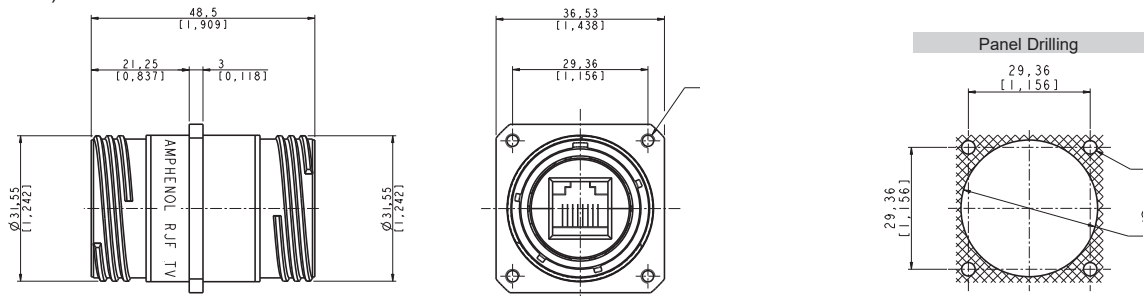

Receptacle - Square flange receptacle - 4 mounting holes - Shell type 2 - Trough-bulkhead - Other coding possibility

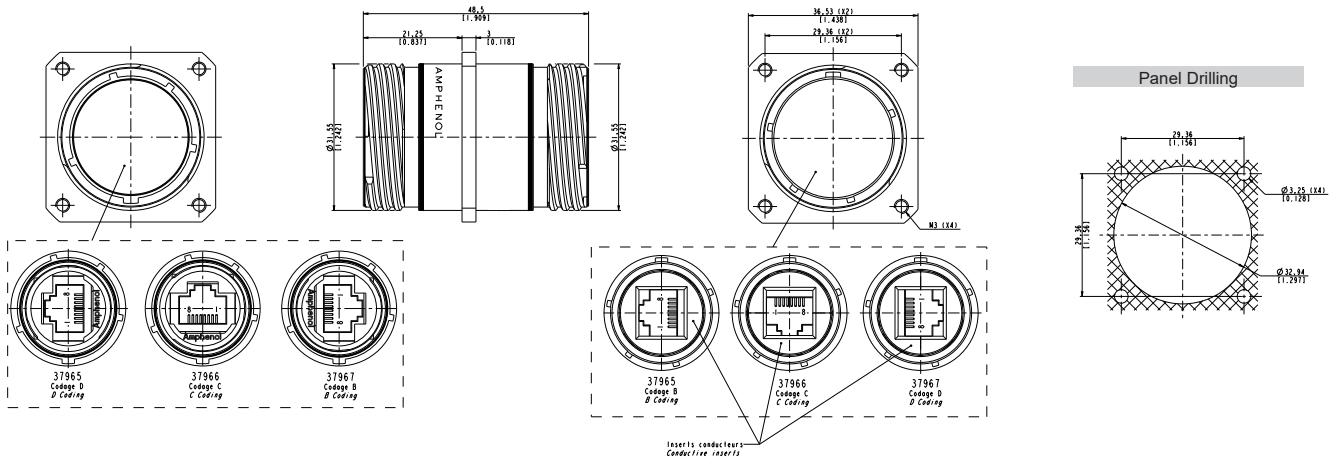

Data transmission	Part number	Metallized insert	Coding	Plating
Cat.5e	37965	Yes	B - D	Nickel ✓
	37966	Yes	C - C	
	37967	Yes	D - B	

✓ : RoHS compliant



# RJFTV™ - THROUGH-BULKHEAD RECEPTACLE

## Overall dimension

Receptacle - Jam nut receptacle - Hexagonal nut mounting - Shell type 7 - Trough-bulkhead

Part number type (Cat.5e) : **RJFTV B 7 X ISO XXX**  
 Part number type (Cat.6) : **RJFTV 6 B 7 X ISO XXX**

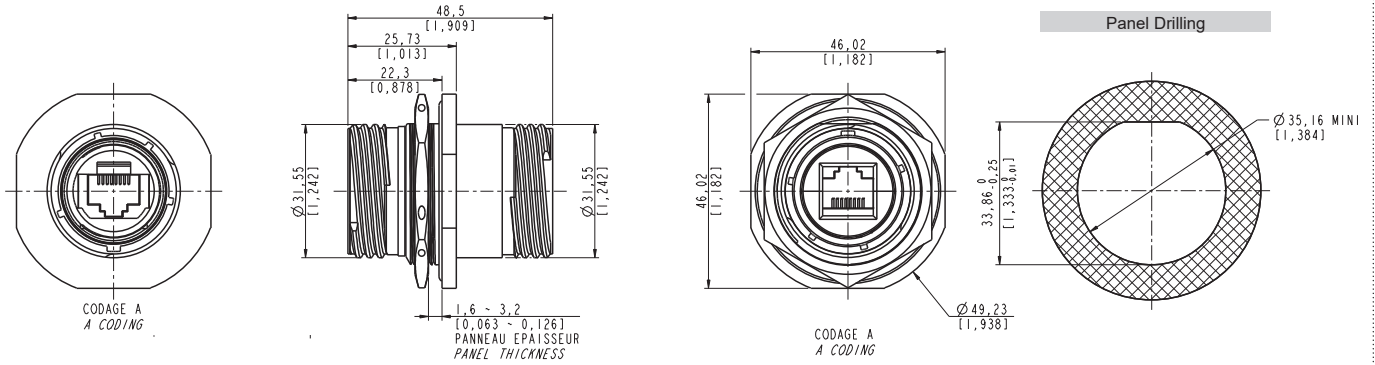

Receptacle - Jam nut receptacle - Hexagonal nut mounting - Shell type 7 - Trough-bulkhead - Other coding possibility

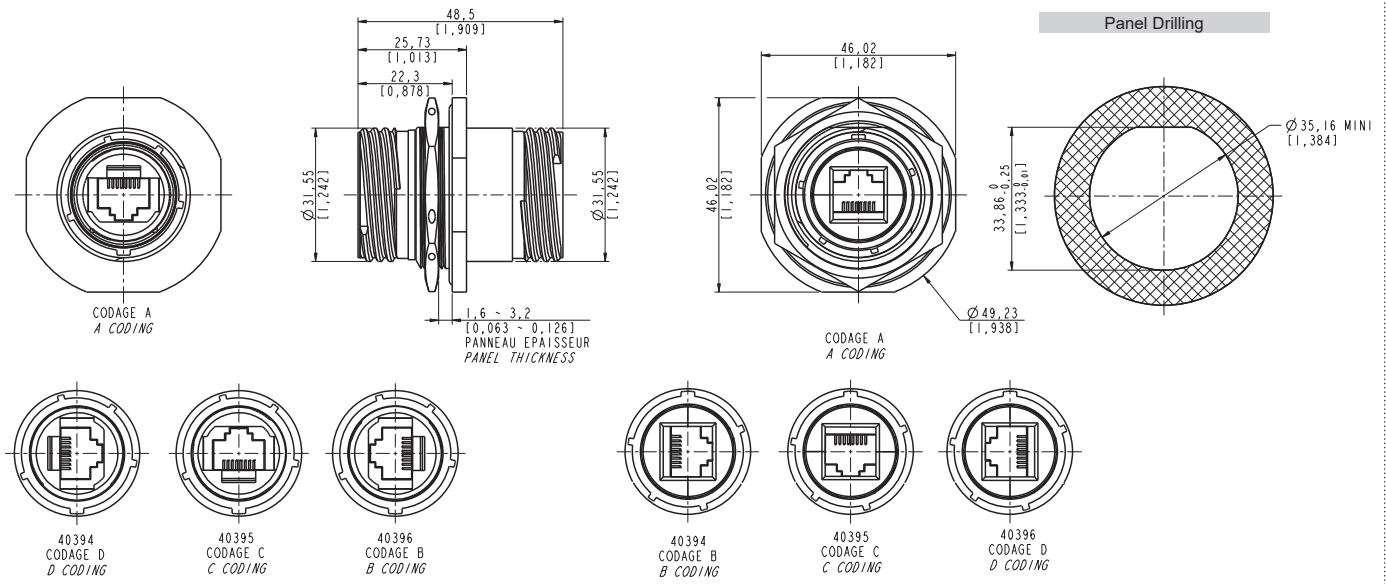

Data transmission	Part number	Metallized insert	Coding	Plating
Cat.5e	<b>40394</b>	Yes	B - D	Nickel ✓
	<b>40395</b>	Yes	C - C	
	<b>40396</b>	Yes	D - B	

✓ : RoHS compliant

# RJFTV™ - PLUG AND RECEPTACLE WITH 360° EMI BACKSHELL



## Description

These RJFTV™ kits include all components necessary to build up a totally 360° EMI shield solution. Receptacle kits are mainly composed of an 360° backshell and the RJFTV™ PCB receptacle with 8 tinned holes for solder termination. With those receptacle kits provided without cable, you will have to solder your cable on the PCB. The plug kit is composed with the 360° backshell where you will have to include your own RJ45 cordset. You can find below, wires and shielding wire cabling specification.

We recommend to use our reinforced Ethernet cable (page 75). If you prefer to use your own cable, please check with us compatibility with our kit.

If you would like to receive a complete 360° EMI shield receptacle already mounted with a define length of cable, please consult us.

## Overall dimension

Plug - Shell type 6 - Straight backshell - Metal gland

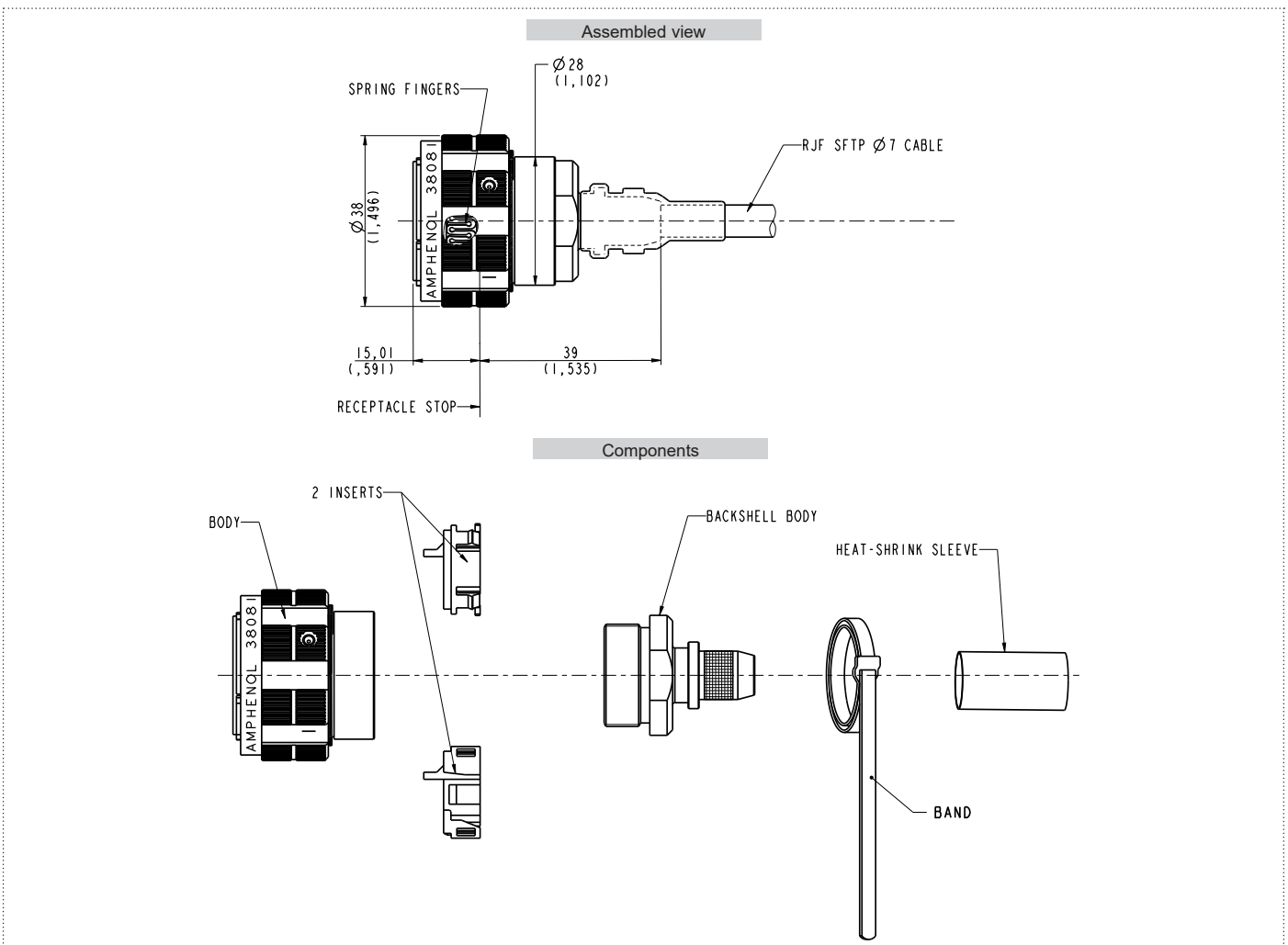

P/N	Plating
<a href="#">KIT38081NI</a>	Nickel ✓
<a href="#">KIT38081</a>	Olive drab cadmium
<a href="#">KIT38081ZN</a>	Black zinc nickel ✓
<a href="#">KIT38081BZ</a>	Marine bronze ✓

✓ : RoHS compliant

Metal range  
Composite range  
Cables and cordsets  
Adaptors and access points  
Accessories  
Assembly instructions  
How to order

# RJFTV™ - PLUG AND RECEPTACLE WITH 360° EMI BACKSHELL

## Overall dimension

Plug - Shell type 6 - Right angle backshell - Metal gland

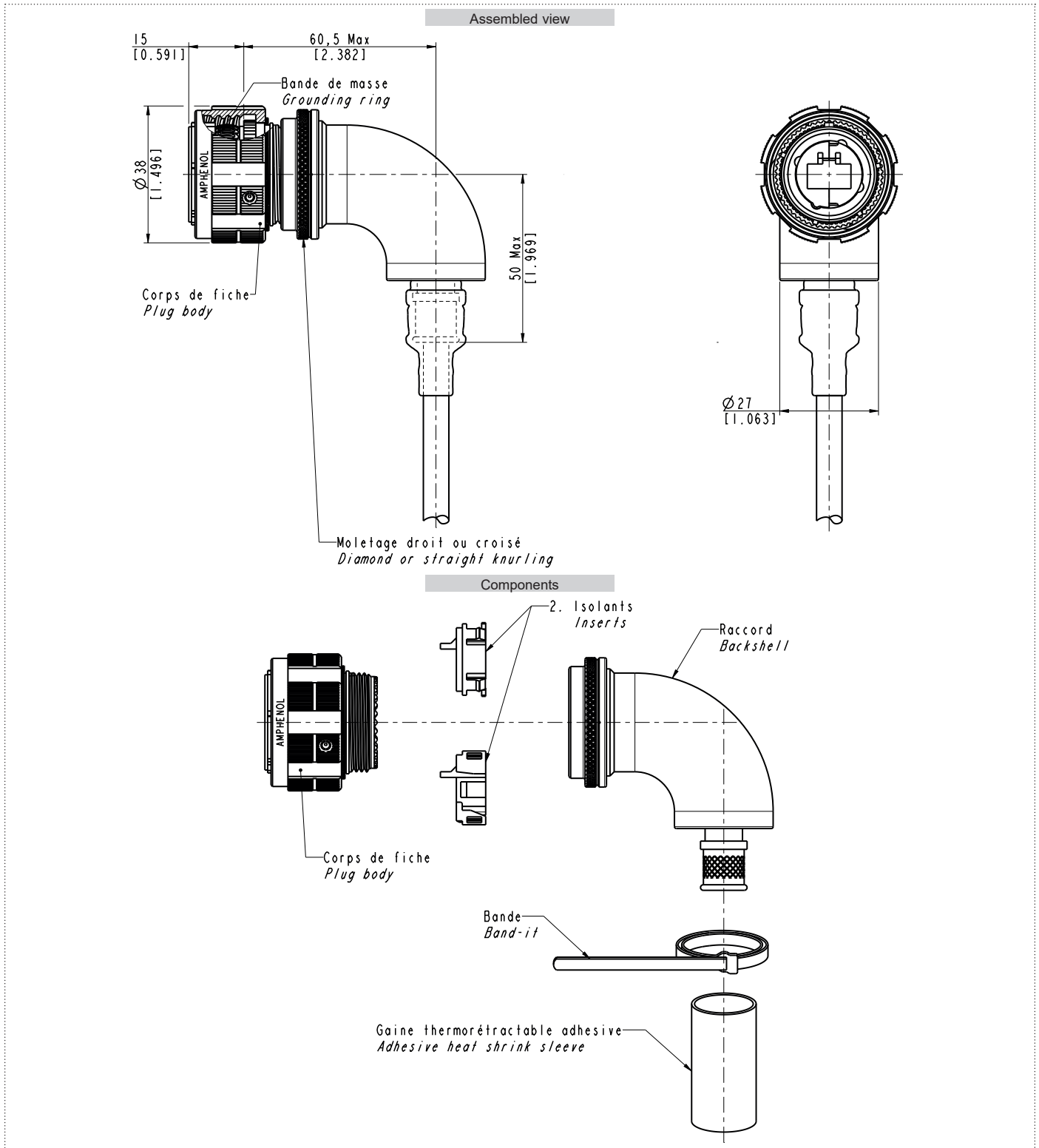

P/N	Plating
<b>KIT40792NI</b>	Nickel ✓
<b>KIT40792</b>	Olive drab cadmium
<b>KIT40792ZN</b>	Black zinc nickel ✓

✓ : RoHS compliant

# RJFTV™ - PLUG AND RECEPTACLE WITH 360° EMI BACKSHELL

## Overall dimension

Plug - Right angle backshell - Metal gland

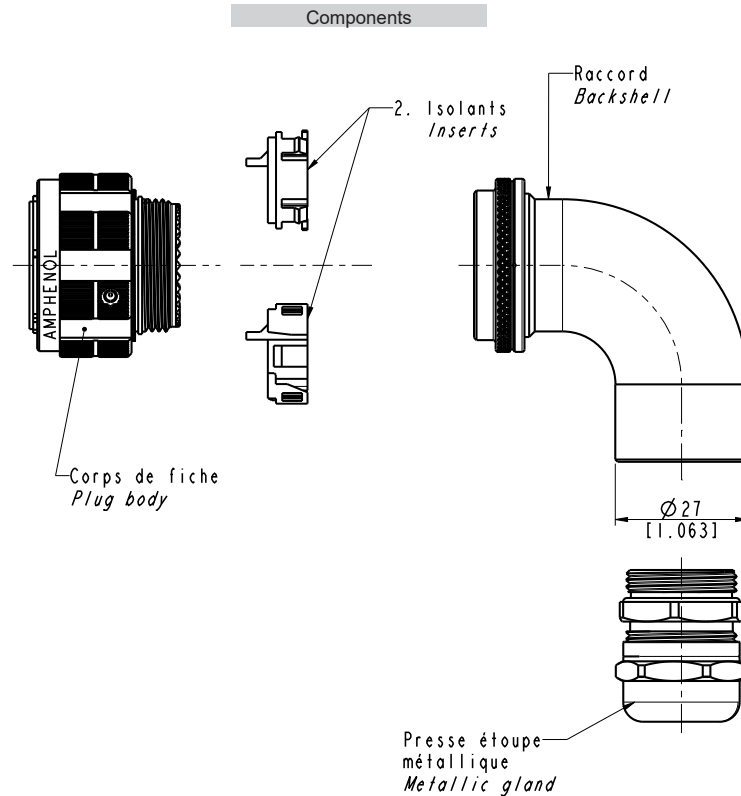
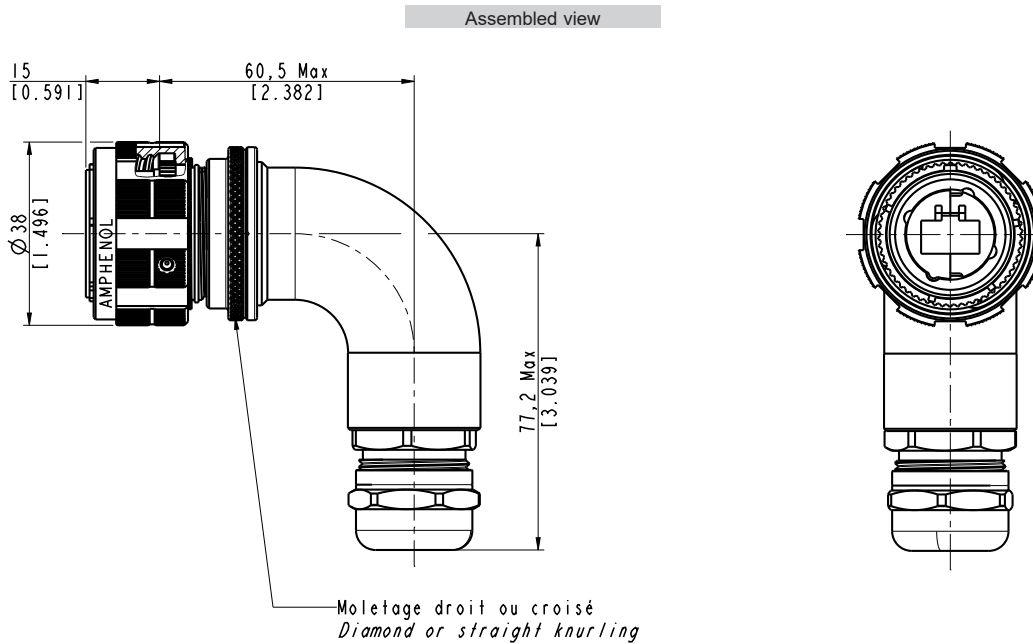

Part number

KIT40036NI

KIT40036G

KIT40036ZN

Plating

Nickel ✓

Olive drab cadmium

Black Zinc Nickel ✓

✓ : RoHS compliant

# RJFTV™ - PLUG AND RECEPTACLE WITH 360° EMI BACKSHELL

## Overall dimension

Square flange receptacle - 4 mounting holes - Shell type 2 - Straight backshell

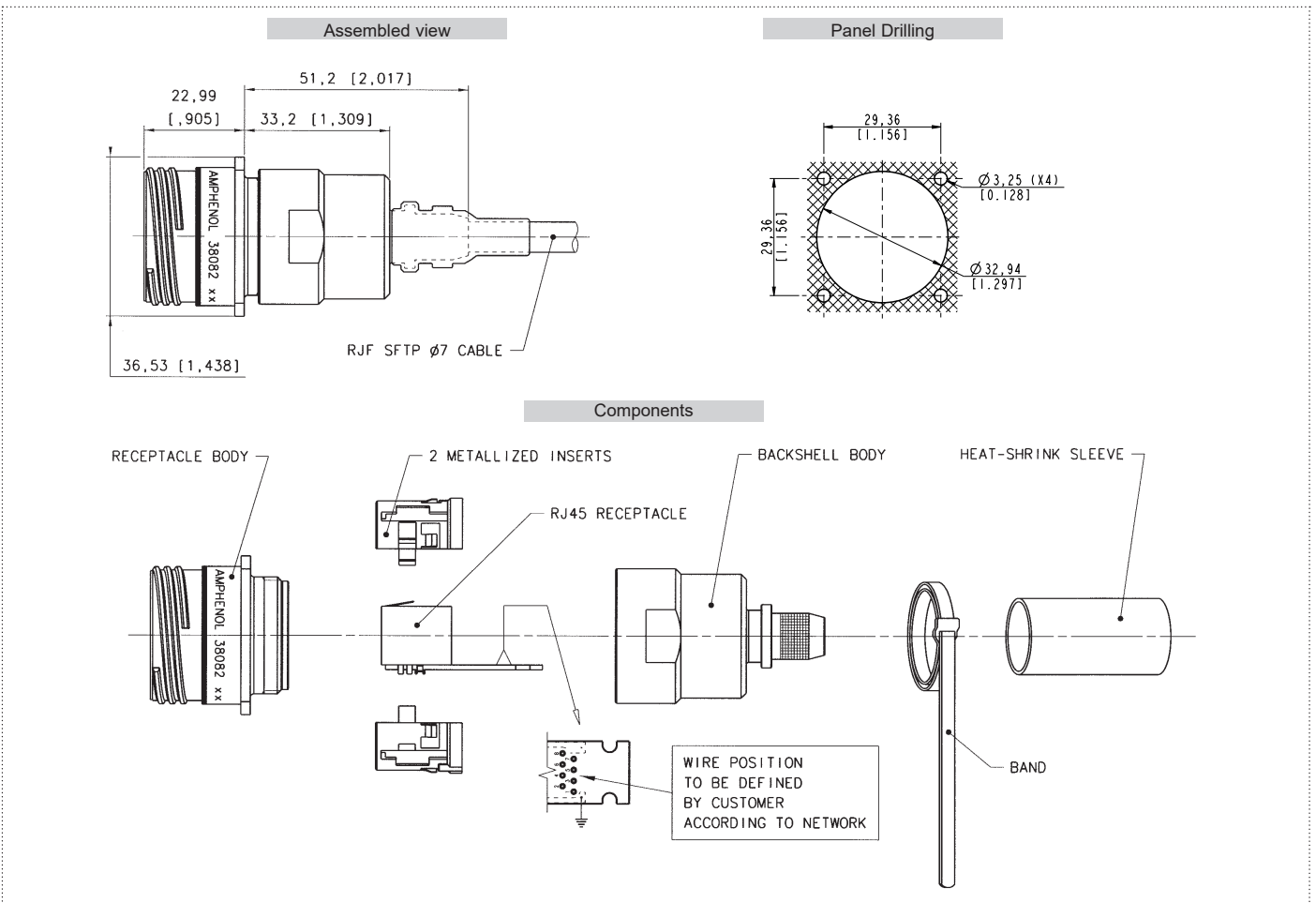

Data transmission	Part number	Plating
Cat.5e	<b>KIT38082NI</b>	Nickel ✓
	<b>KIT38082</b>	Olive drab cadmium
	<b>KIT38082ZN</b>	Black zinc nickel ✓
	<b>KIT38082BZ</b>	Marine bronze ✓

✓ : RoHS compliant

# RJFTV™ - PLUG AND RECEPTACLE WITH 360° EMI BACKSHELL

## Overall dimension

Square flange receptacle - 4 mounting holes - Shell type 2 - Right angle backshell

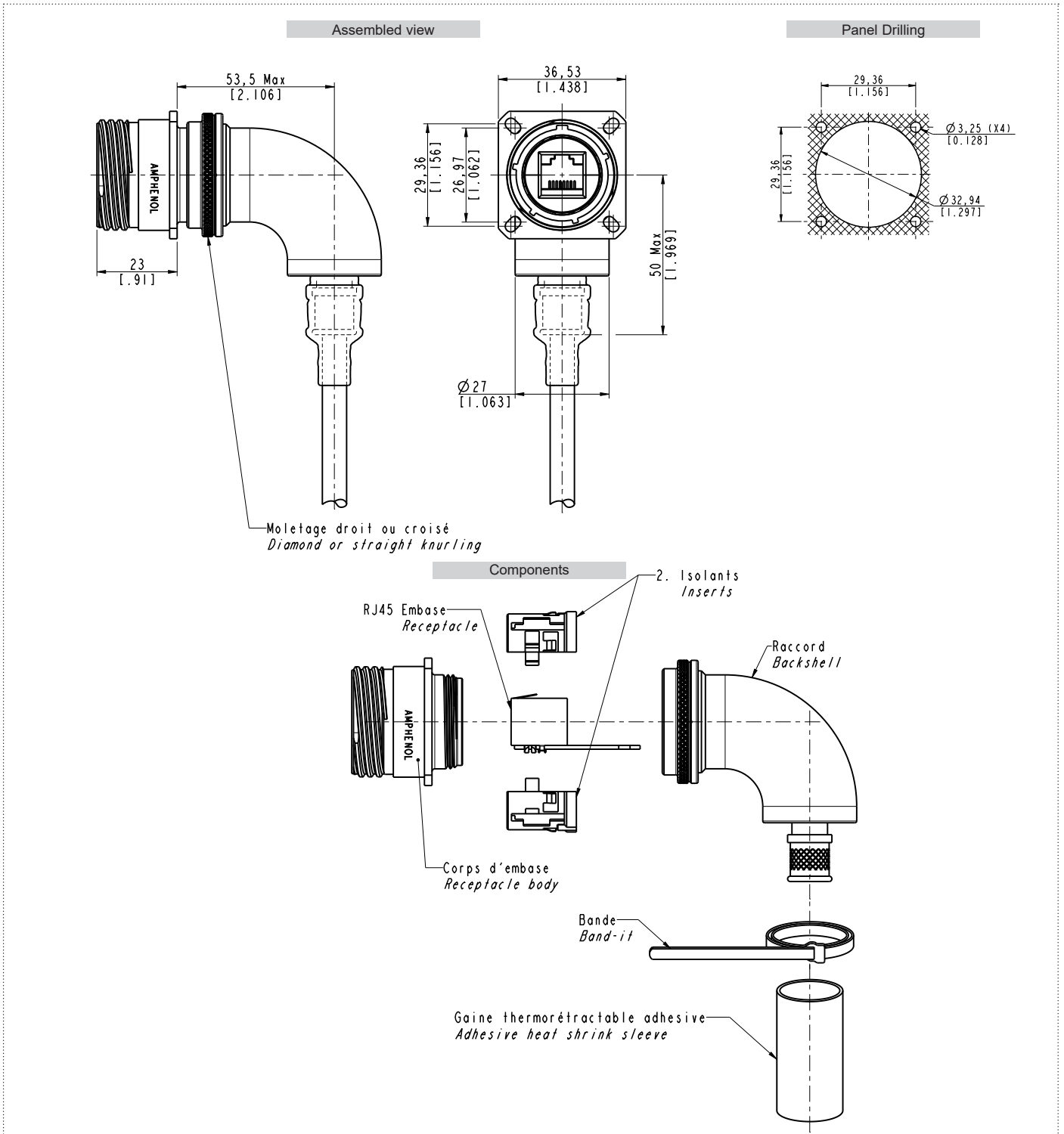

Data transmission	Part number	Plating
Cat.5e	KIT40791NI	Nickel ✓
	KIT40791	Olive drab cadmium
	KIT40791ZN	Black zinc nickel ✓

✓ : RoHS compliant

# RJFTV™ - PLUG AND RECEPTACLE WITH 360° EMI BACKSHELL

## Overall dimension

Jam nut receptacle - Hexagonal nut mounting - Shell type 7 - Straight backshell

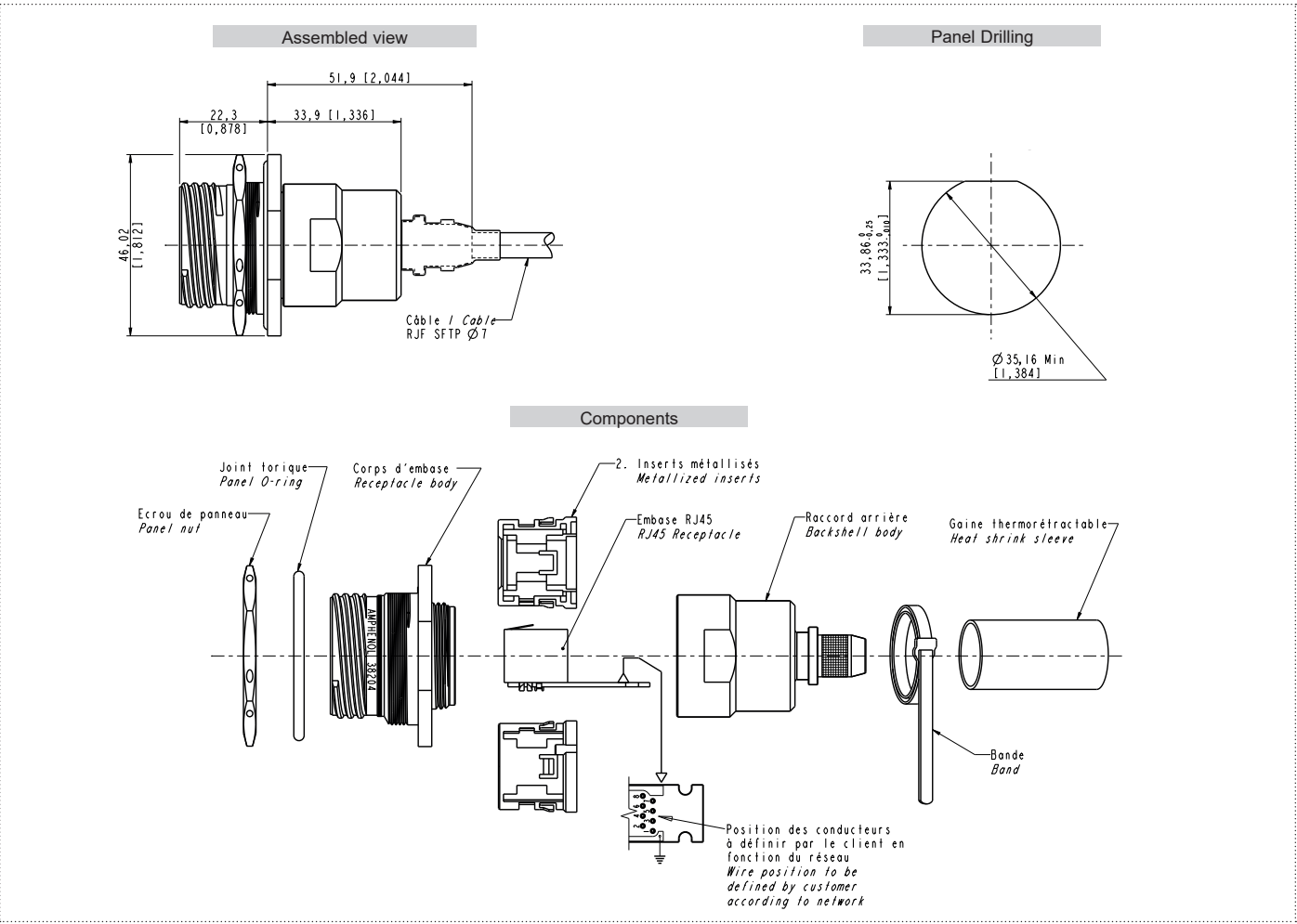

Data transmission	Part number	Plating
Cat.5e	KIT38204NI	Nickel ✓
	KIT38204	Olive drab cadmium
	KIT38204ZN	Black zinc nickel ✓
	KIT38204BZ	Marine bronze ✓

✓ : RoHS compliant

# RJFTV™ - PLUG AND RECEPTACLE WITH 360° EMI BACKSHELL

## Overall dimension

Jam nut receptacle - Hexagonal nut mounting - Shell type 7 - Right angle backshell

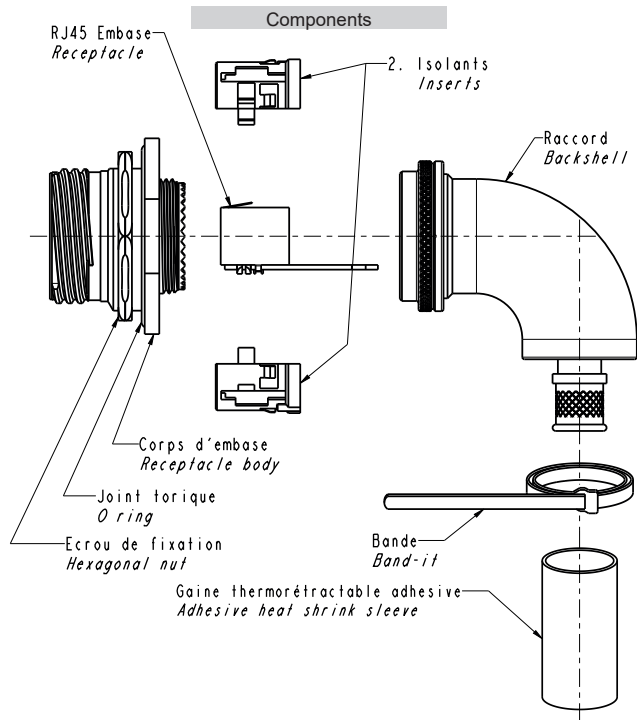
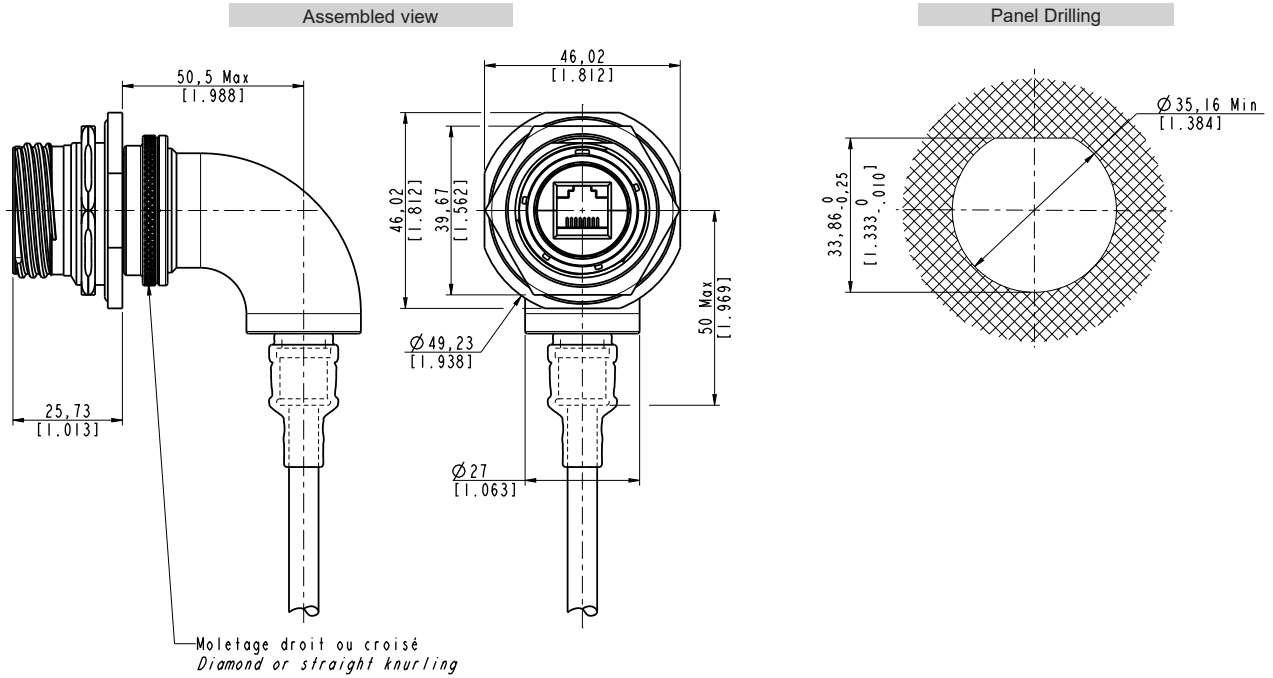

Data transmission	Part number	Plating
Cat.5e	KIT40771NI	Nickel ✓
	KIT40771	Olive drab cadmium
	KIT40771ZN	Black zinc nickel ✓

✓ : RoHS compliant



# RJFTV™ - PLUG AND RECEPTACLE FOR BIG INSULATION WIRE UP TO 1.6 MM



## Description

This RJFTV kit includes all the necessary components to assemble a RJFTV plug, particularly if you foresee using a large ethernet cable. The kits are composed of a specific RJ45 Cat6A plug that should be crimped to the cable. The adhesive metal tape and the heat shrink boot provide a proper finish and electrical insulation. Finally, the RJStop that is included in this kit, is perfectly adapted to the RJ45 Cat6A plug.

### Plug - Shell type 6 - Metal gland

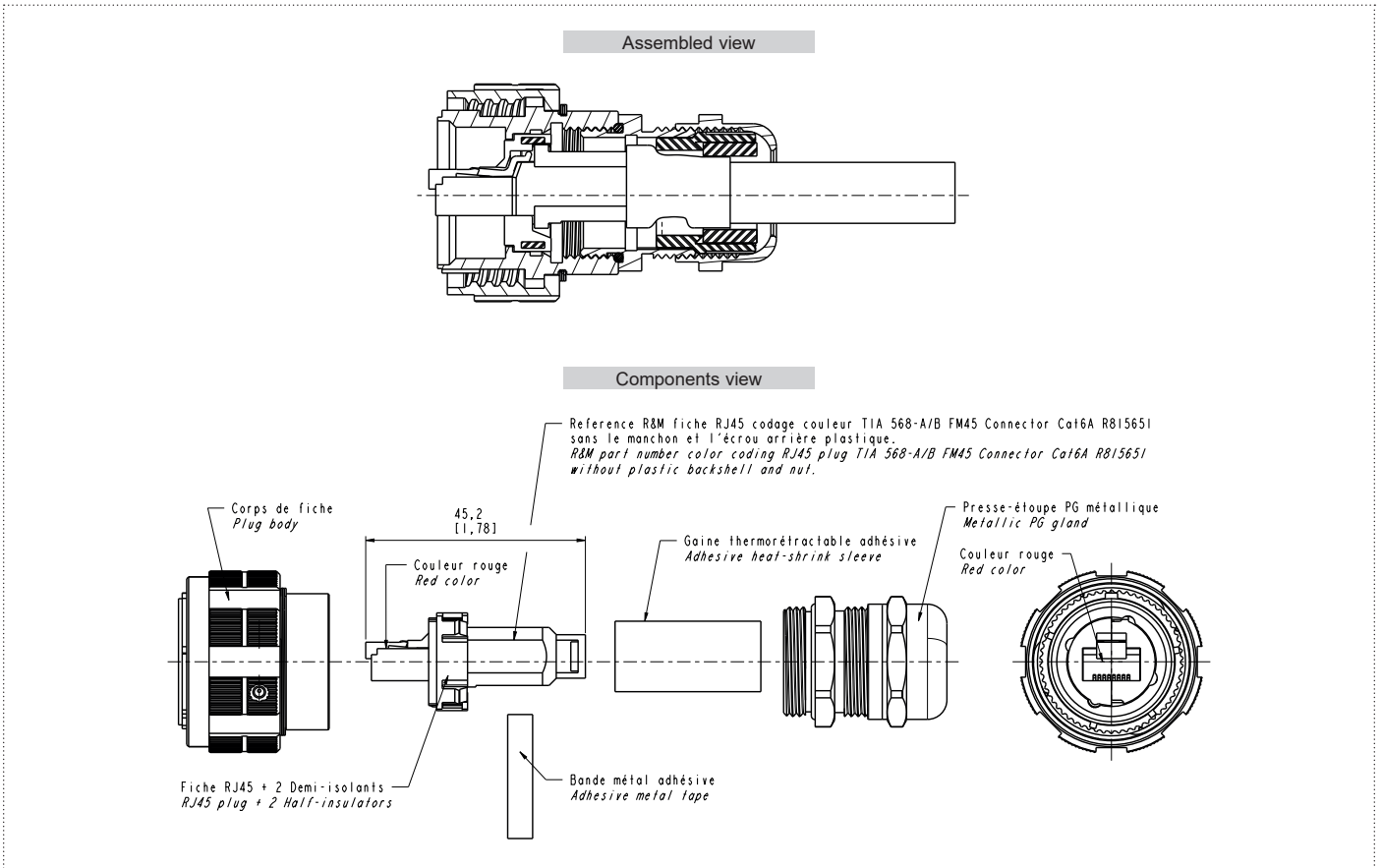

Data transmission	Part number	Plating
Cat.6A	35660	Nickel ✓
	35660G	Olive drab cadmium
	35660ZN	Black zinc nickel ✓
	35661	Marine bronze ✓

✓ : RoHS compliant

# RJFTV™ - PLUG AND RECEPTACLE FOR BIG INSULATION WIRE UP TO 1.6 MM

## Overall dimension

### Plug - Shell type 6

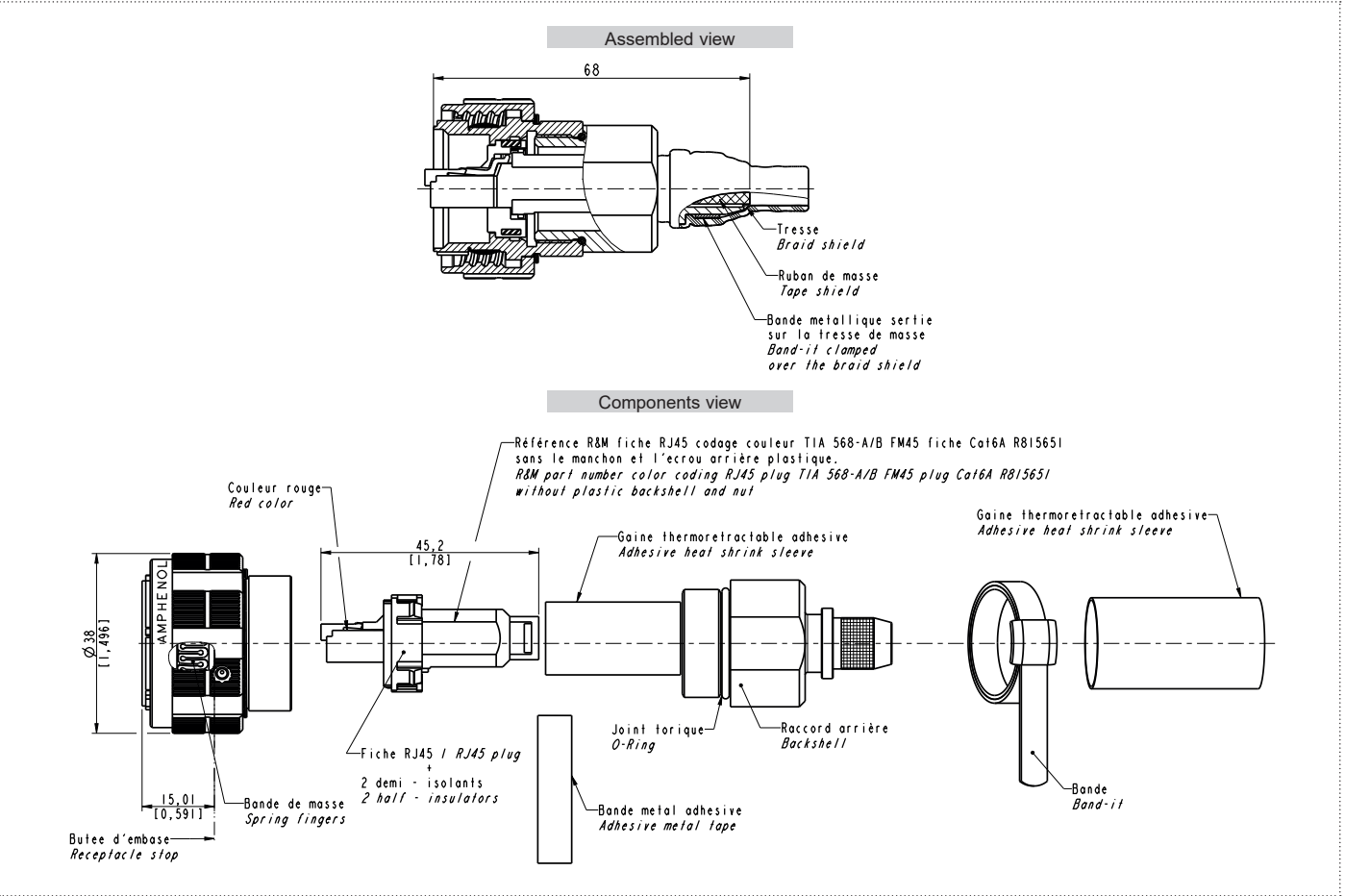

Data transmission	Part number	Plating
Cat.6A	35498N	Nickel ✓
	35498	Olive drab cadmium
	35498ZN	Black zinc nickel ✓
	35498BZ	Marine bronze ✓

✓ : RoHS compliant

# RJFTV™ - PLUG AND RECEPTACLE FOR BIG INSULATION WIRE UP TO 1.6 MM

## Overall dimension

Square flange receptacle - 4 mounting holes - Shell type 2 - Backshell with metal gland

Assembled view

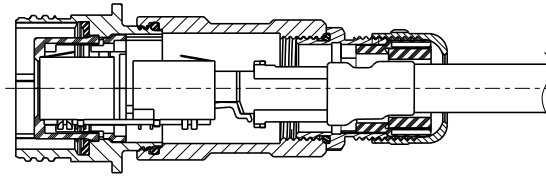

Components view

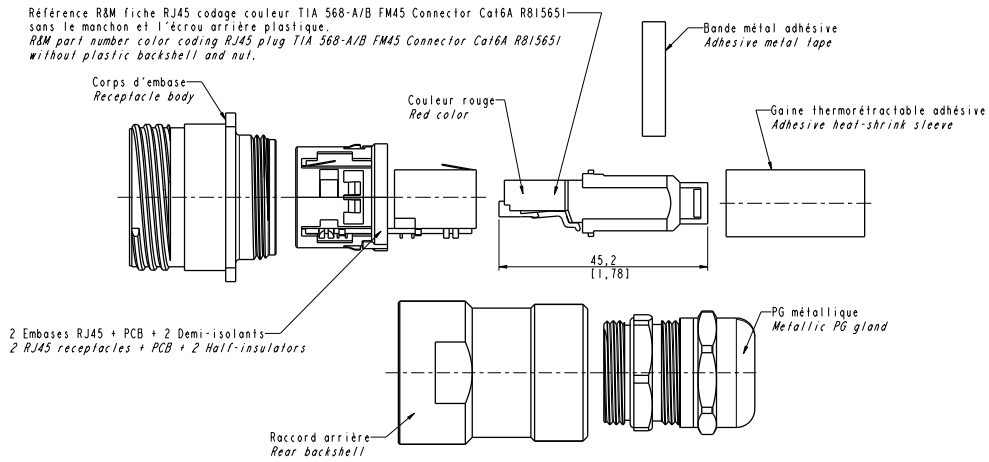

Data transmission	Part number	Plating
Cat.6A	35657	Nickel ✓
	35657G	Olive drab cadmium
	35657ZN	Black zinc nickel ✓
	35658	Marine bronze ✓

✓ : RoHS compliant

# RJFTV™ - PLUG AND RECEPTACLE FOR BIG INSULATION WIRE UP TO 1.6 MM

## Overall dimension

Jam nut receptacle - Hexagonal nut mounting - Shell type 7 - Backshell with metal gland

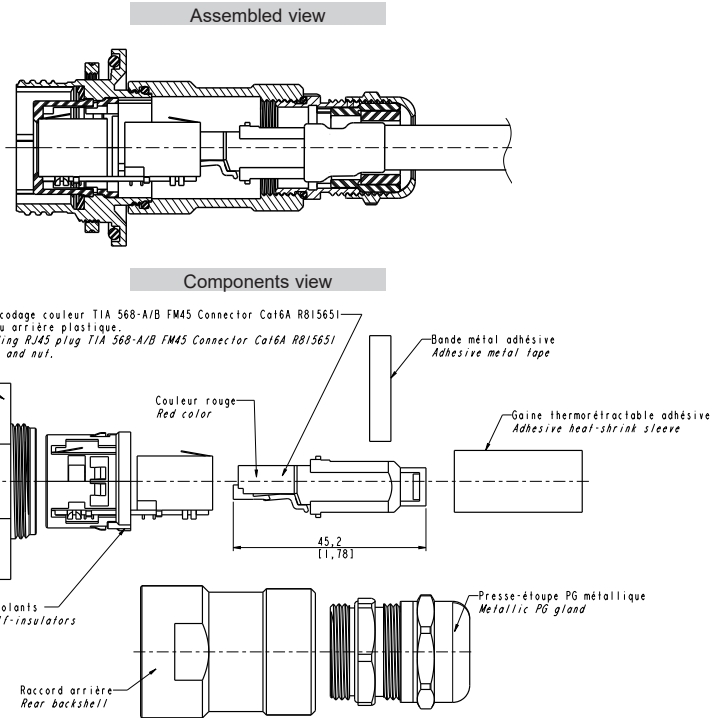

Data transmission	Part number	Plating
Cat.6A	35688	Nickel ✓
	35688G	Olive drab cadmium
	35688ZN	Black Zinc Nickel ✓
	35689	Marine Bronze ✓

✓ : RoHS compliant

Metal range  
 Composite range  
 Cables and cordsets  
 Adaptors and access points  
 Accessories  
 Assembly instructions  
 How to order

## RJFTV™ - ATEX ZONE 2

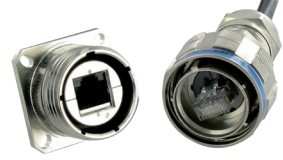

## Description

RJFTVX connectors are certified for use in explosive environments. This range is designed to be used in ATEX zone 2 environments and 100% tested at 500V during 1 minute without sparking.

## MAIN CHARACTERISTICS

- Ex marking : II3G ExnAII T6 X
- Operating temperature range : -40°C / +60°C
- Voltage : 60 Veff max
- Power : 20 W max
- Outside cable diameter : 6mm to 12mm
- Sealing : IP68

## DATA TRANSMISSION

- 10 BaseT, 100 BaseTX and 1000 BaseT networks
- Cat 5e per TIA/EIA 568B and ClassD per ISO/IEC 11801
- Cat.6 per TIA/EIA 568B and ClassE per ISO/IEC 11801
- Cat.6A per TIA/EIA 568B and ClassEa per ISO/IEC 11801

**How to order :** Please refer to page 118

## Back terminations

Type 1:  
Female RJ11

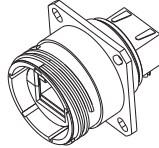

## Overall dimension

Atex plug - Shell type 6

Part number type : **RJFTVX 6 M X**

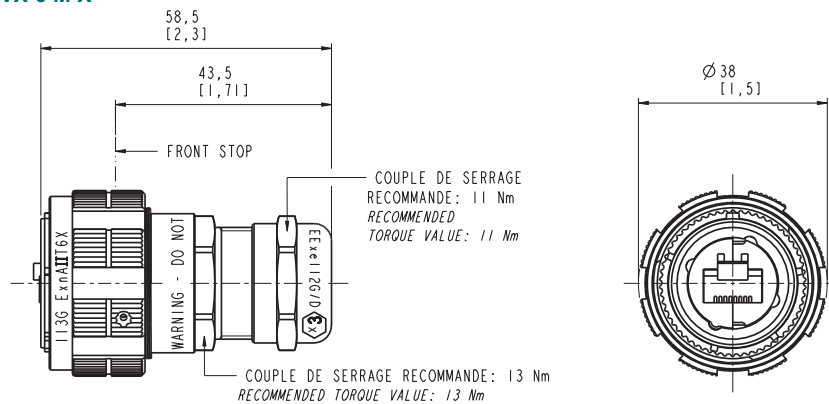

# RJFTV™ - ATEX ZONE 2

## Overall dimension

**Atex receptacle - Square flange receptacle - 4 mounting holes - Shell type 2 - Back termination type 1**

Part number type (Cat.5e) : **RJFTVX 2 SX 1 X**  
 Part number type (Cat.6) : **RJFTVX 6 2 SX 1 X**

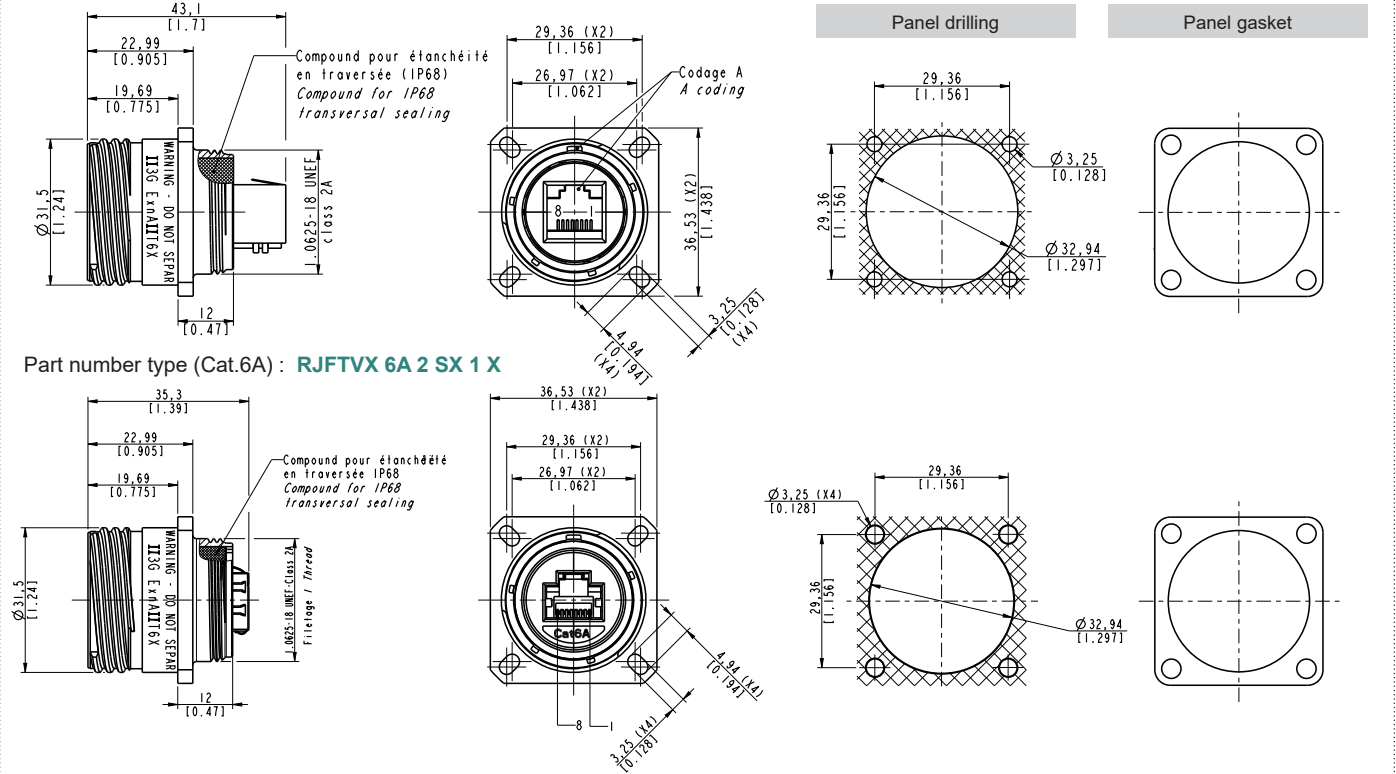

**Atex receptacle - Jam nut receptacle - Hexagonal nut mounting - Shell type 7 - Back termination type 1**

Part number type (Cat.5e) : **RJFTVX 7 SX 1 X**  
 Part number type (Cat.6) : **RJFTVX 6 7 SX 1 X**

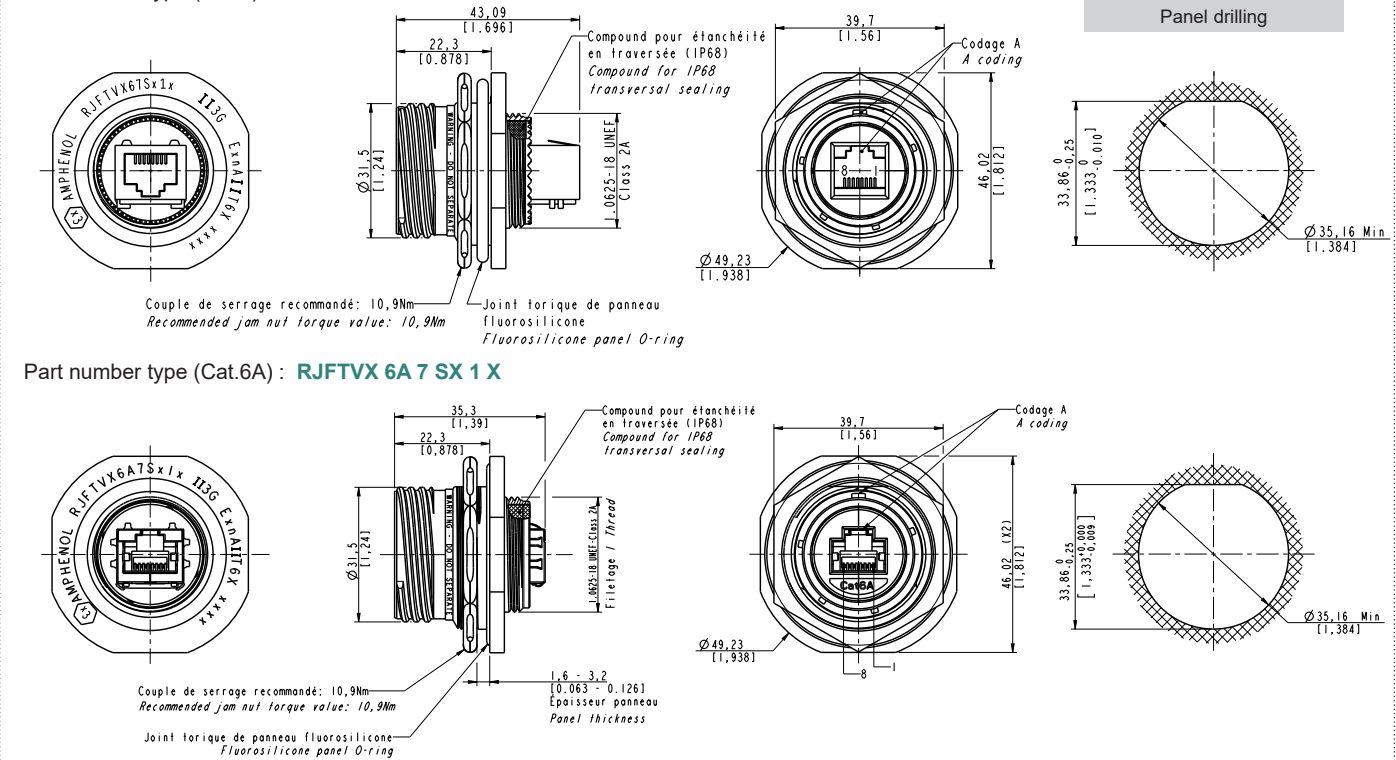

# RJFTV™ - ATEX ZONE 2

## Overall dimension

**Atex receptacle - Square flange receptacle - 4 mounting holes - Shell type 2 - Backshell with metal gland**

Part number type (Cat.5e) : **RJFTVX 2 SX PEM 1 X**  
 Part number type (Cat.6) : **RJFTVX 6 2 SX PEM 1 X**

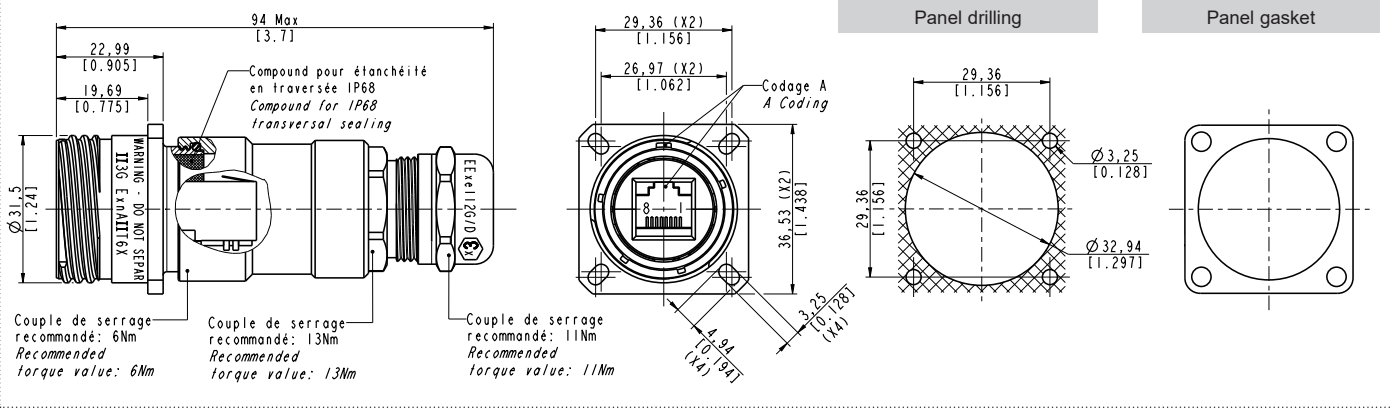

**Atex receptacle - Jam nut receptacle - Hexagonal nut mounting - Shell type 7 - Backshell with metal gland**

Part number type (Cat.5e) : **RJFTVX 7 SX PEM 1 X**  
 Part number type (Cat.6) : **RJFTVX 6 7 SX PEM 1 X**

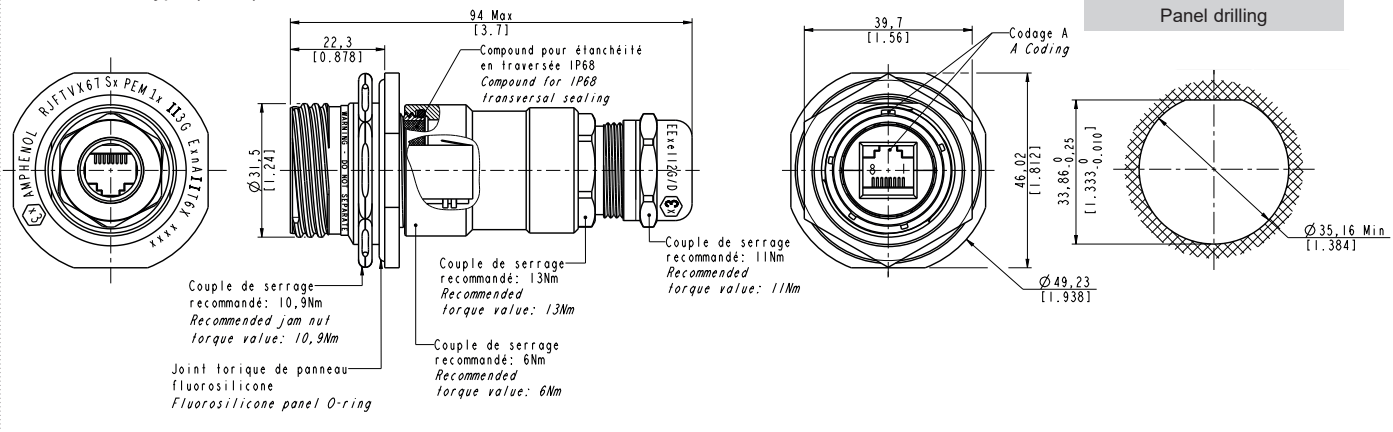

## RJ11FTV - ATEX ZONE 2



### Description

RJ11FTVX connectors allow you to use a standard RJ11 connection in Atex zone 2 environments. This range is designed to be used in Atex zone 2 environments and 100% tested at 500V during 1 minute without sparking. This solution has several advantages. The assembly of your solutions is fast and easy because you don't need any tool. You can choose between four different codings on the plug and receptacle side. With the help of dedicated tool you can remove the insert of the receptacle in order to change the coding if needed. You can also use it for reparation or maintenance. Everything can be done in place.

### Main features

#### MAIN CHARACTERISTICS

- Ex marking : II3G ExnAIIIT6 X
- Operating temperature range : -40°C / +60°C
- Voltage : 60 Veff max
- Power : 20 W max
- Outside cable diameter : 4 to 5,5mm
- Sealing : IP68

**How to order :** Please refer to page 119

### Back terminations

Type 1:  
Female RJ11

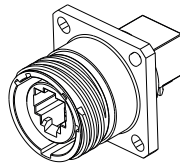

### Overall dimension

Atex plug - Shell type 6

Part number type : **RJ11FTVX 6 M X**

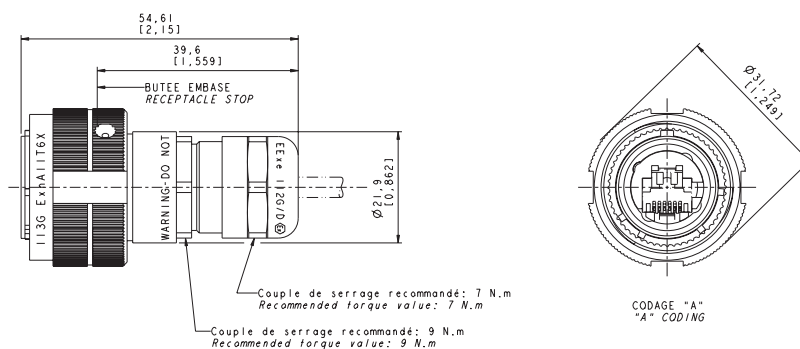

✓ : RoHS compliant



# RJ11FTV - ATEX ZONE 2

## Overall dimension

### Atex square flange receptacle - 4 mounting holes - Shell type 2

Part number type : **RJ11FTVX 2 SA 1 X**

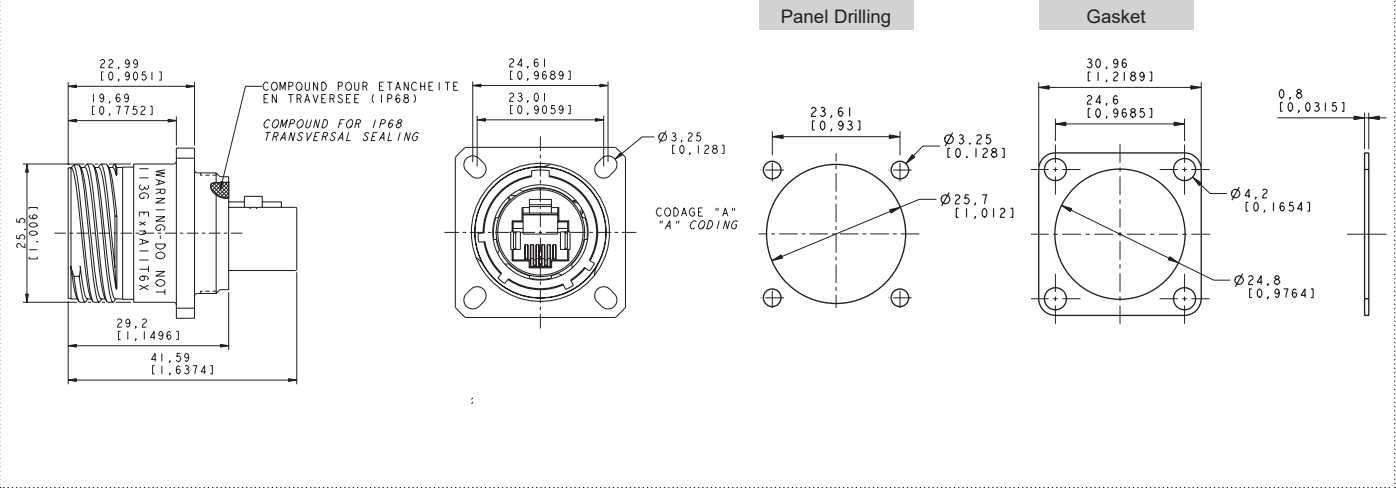

### Atex jam nut receptacle - Hexagonal nut mounting - Shell type 7

Part number type : **RJ11FTVX 7 SA 1 X**

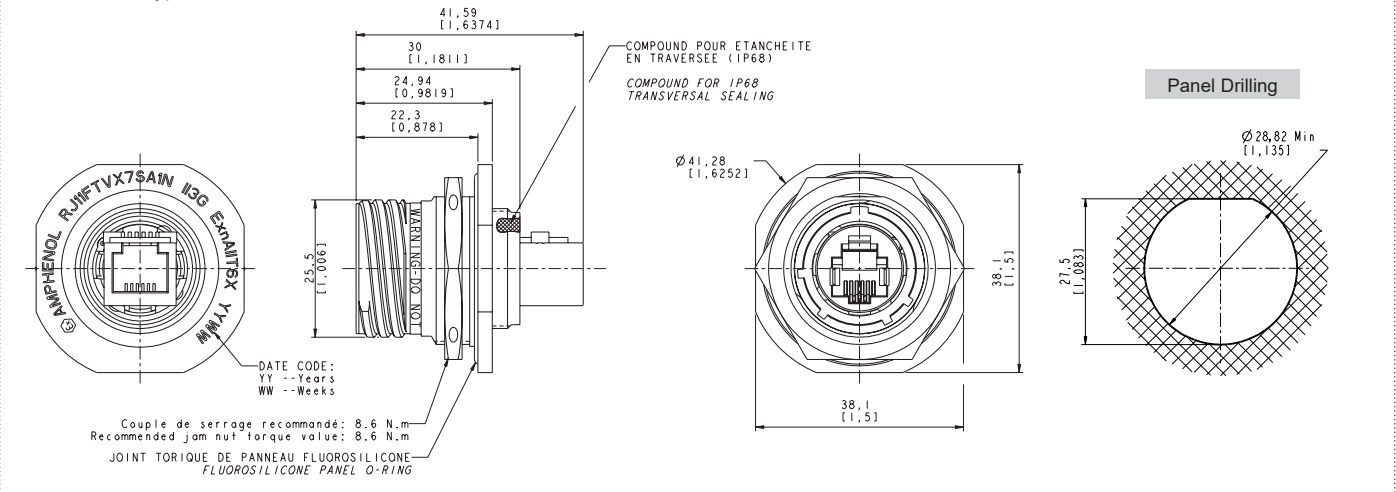

**Important note:**

- Due to the compound, the coding orientation has to be define in the reference.
- To choose your coding orientation, please refer to "Assembly instructions" page 104.



# COMPOSITE RANGE



## Table of contents

<b>COMPOSITE RANGE</b>	<b>67</b>
RJFRB	68
RJF544	71

- Metal range
- Composite range**
- Cables and cordsets
- Adaptors and access points
- Accessories
- Assembly instructions
- How to order

## RJFRB



## Description

The RJFRB is a ruggedized composite connector with reverse bayonet coupling. You can use your standard RJ45 cordset, clipping it into the plug to obtain a reinforced solution. The receptacle is also easy to install, especially concerning IDC versions (Insulation Displacement Contact) possible in three different shielding options. This solution is perfectly suitable for an industrial environment for quick coupling solution.

## Main features

### MAIN CHARACTERISTICS

- Sealed against fluids and dust (IP68)
- Shock, vibration and traction resistant
- No cabling operation in field, no tools required
- Reverse bayonet coupling
- RJ45 cordset retention in the plug: 70 N in the axis
- Mating cycles: 500 min
- Compatible with cable diameter from 5,5 mm [0.216 in] to 7 mm [0.275 in]

### DATA TRANSMISSION

- 10 BaseT, 100 BaseTX and 1000 BaseT networks
- Cat.5e per TIA/EIA 568B and ClassD per ISO/IEC 11801
- Cat.6 per TIA/EIA 568B and ClassE per ISO/IEC 11801

### ENVIRONMENTAL PROTECTION

- Sealing: IP68
- Salt spray: 1000 h
- Fire retardant / Low smoke: UL94 V0 and EN45545
- Operating temperature: - 40°C / +85°C

### APPLICATIONS

- Telecom equipments
- Video control
- Robotics
- Industrial process control
- CNC machines
- Special machines
- Motion control

**How to order :** Please refer to page 120

## Overall dimension

Plug - Shell type 6

Part number type : **RJFRB 6**

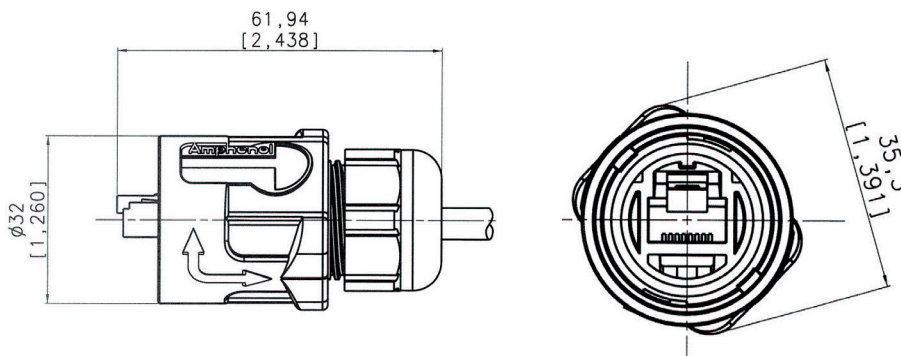

# RJFRB

## Overall dimension

### Receptacle - Shell type 1 - Front mounting - Female RJ45

Part number type (Cat.5e) : **RJFRB 7 1**

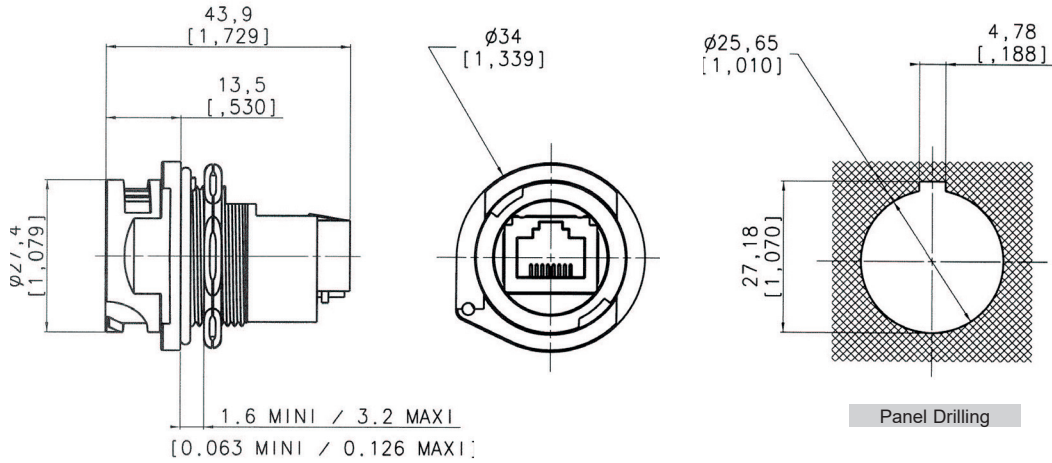

### Receptacle - Shell type 1RA - Front mounting - Female RJ45

Part number type (Cat.5e) : **RJFRB 7 1RA**

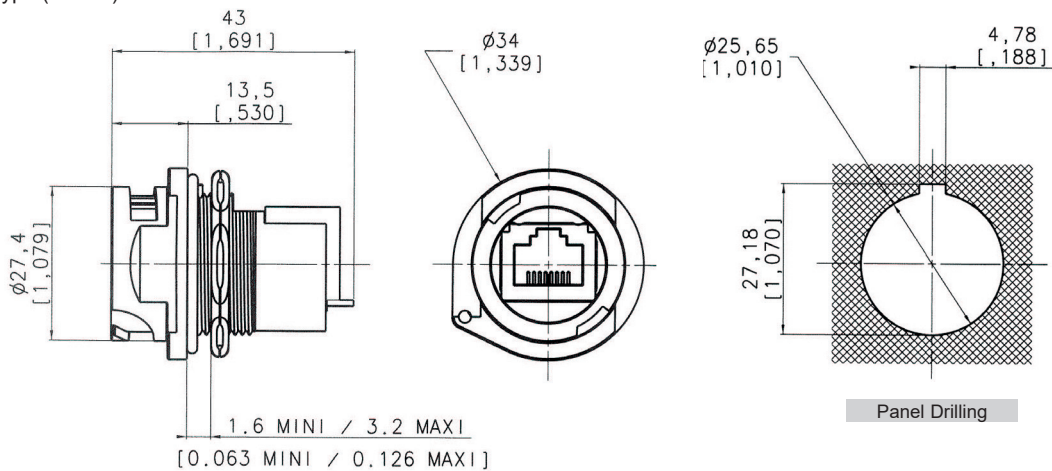

### Receptacle - Shell type 2 - Front mounting - RJ45 cordset

Part number type (Cat.5e) : **RJFRB 7 2 XX 100BTX**

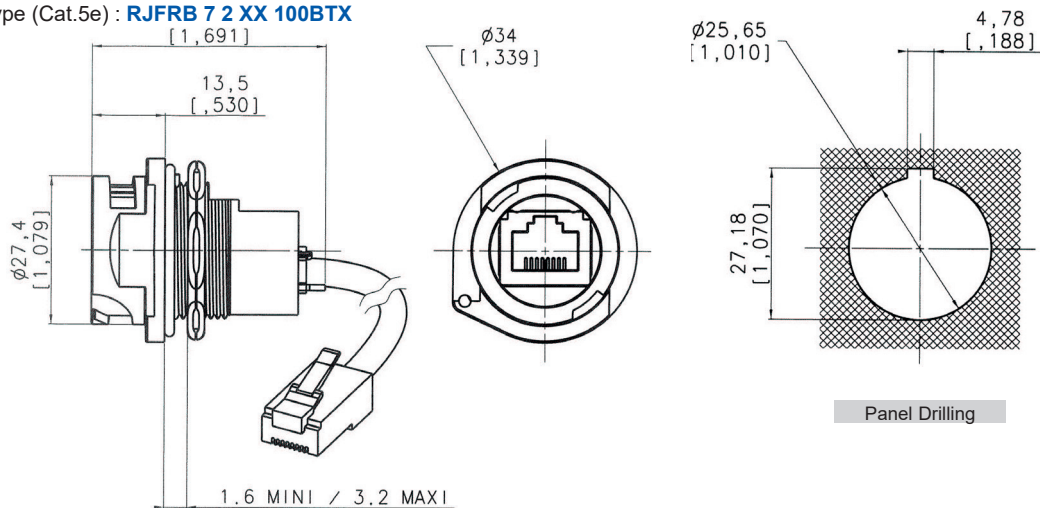

# RJFRB

## Overall dimension

Receptacle - Shell type 3 - Rear mounting - IDC CAT 6 termination - Unshielded, partially shielded or shielded

Part number type (Cat.6) : **RJFRB 7 3X**

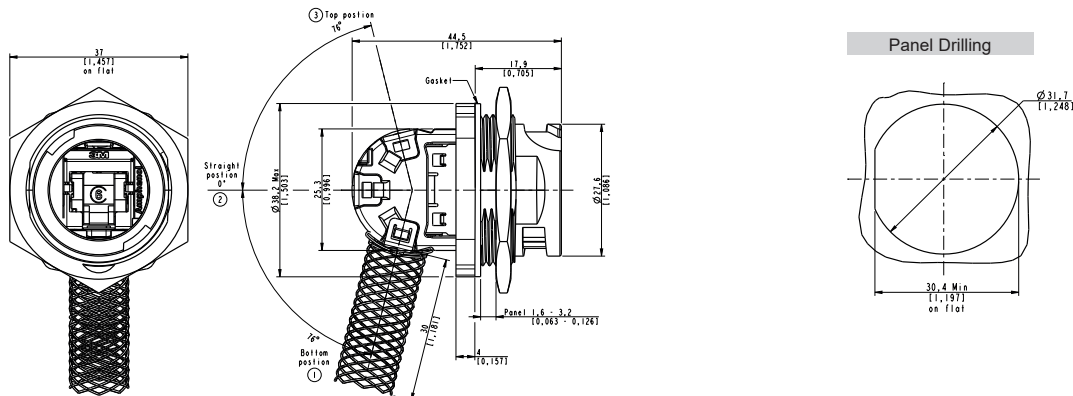

Receptacle - Shell type 5 - Rear mounting - PC tails

Part number type (Cat.5e) : **RJFRB 7 5**

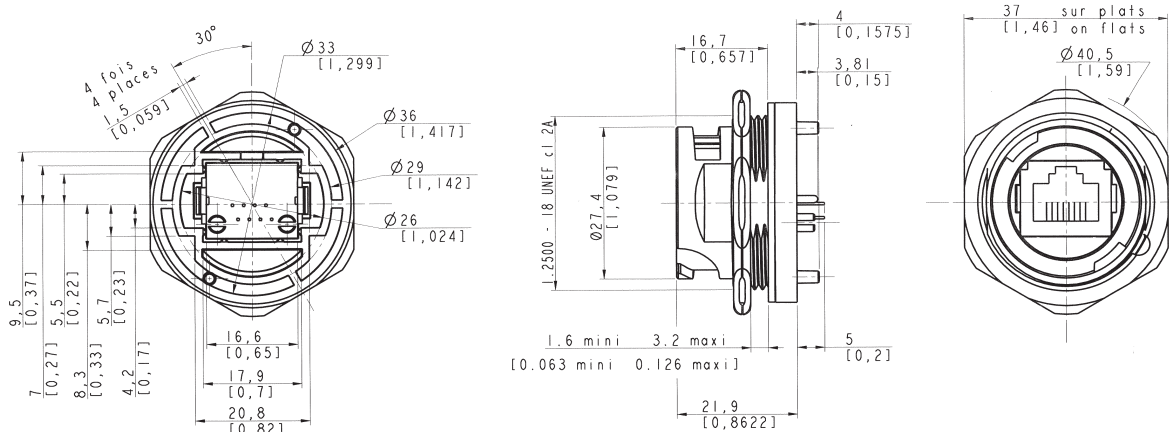

### PCB drilling

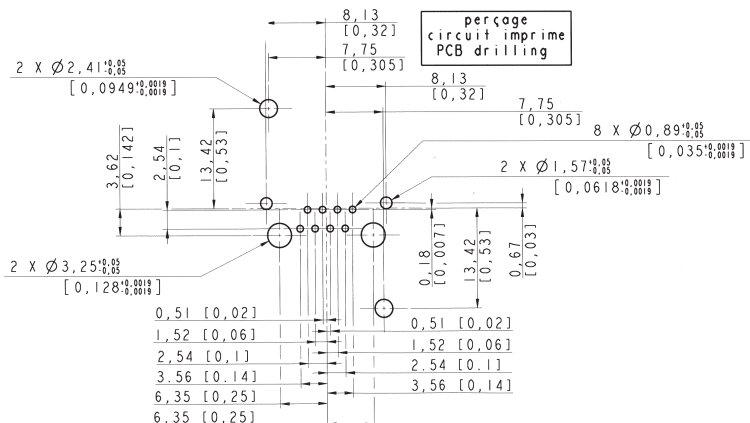

## RJF544

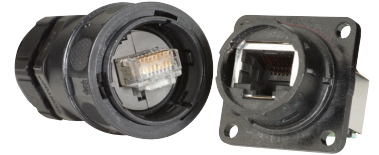

## Description

The RJF544 can be connected on its receptacle using a quick and easy push-pull mechanism. These ruggedized composite shells are easily mounted with our patented RJStop. The receptacle on equipment can be configured with three types of outputs. Simply with another socket RJ45 receptacle straight or right angled, an RJ45 cordset where you can define the length or a PCB to solder your own cable.

## Main features

### MAIN CHARACTERISTICS

- Compliant with IEC 60603-7 variante 12
- Shock, vibration and traction resistant
- No cabling operation in field and no tools required
- Sealed against fluids and dust (IP68)
- Quick push pull coupling
- RJ45 cordset retention in the plug: 100 N in the axis
- Mating cycles: 500 min
- Improved EMI Protection
- Compatible with cable diameter from 6 mm [0.236 in] to 13 mm [0.512 in]

### DATA TRANSMISSION

- 10 BaseT, 100 BaseTX and 1000 BaseT networks
- Cat.5e per TIA/EIA 568B and ClassD per ISO/IEC 11801
- Cat.6 per TIA/EIA 568B and ClassE per ISO/IEC 11801

### ENVIRONMENTAL PROTECTION

- Sealing: IP68
- Salt spray: 1000 h
- Fire retardant / Low smoke: UL94 V0 and NFF 16102, DIN 5510-2
- Vibrations: 10 – 500 Hz, 10 g, 3 axes: no discontinuity > 10 nano s.
- Operating temperature: - 40°C / +85°C

### APPLICATIONS

- Telecom equipment
- Video control
- Robotics
- Industrial process control
- CNC machines
- Special machines
- Motion control
- Tele-maintenance

**How to order :** Please refer to page 121

## Back terminations

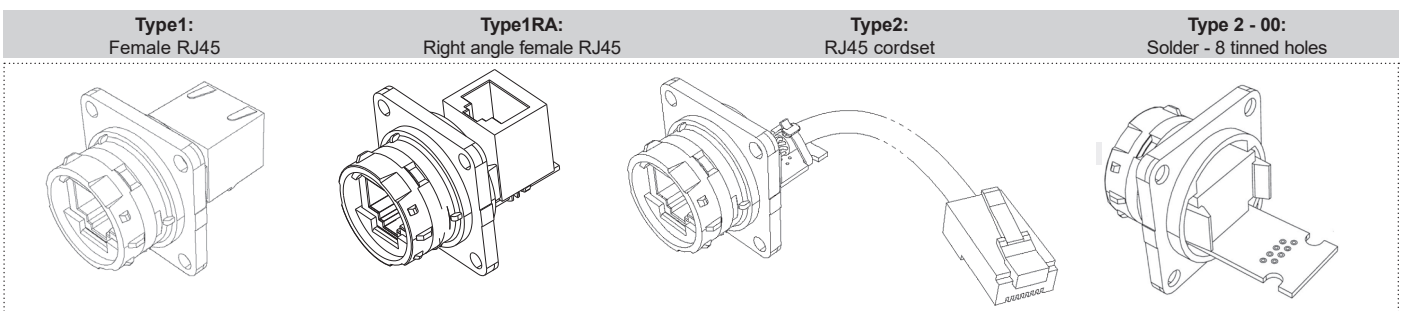

# RJF544

## Overall dimension

### Plug - Shell type 6

Part number type : **RJF544 6**

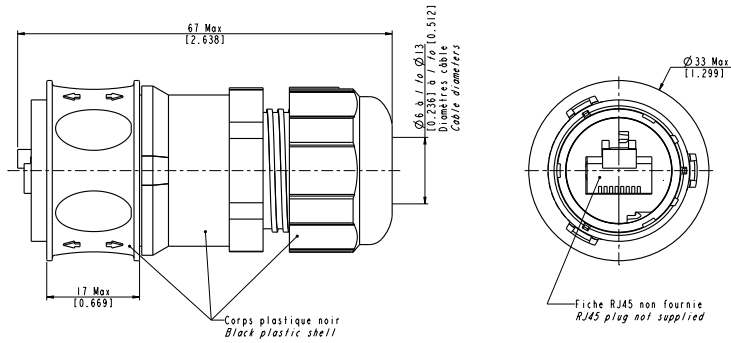

### Receptacle - Square flange receptacle - 4 mounting holes - Shell type 2 - Back termination type 1

Part number type (Cat.5e) : **RJF544 2 X 1**  
 Part number type (Cat.6) : **RJF5446 2 X 1**

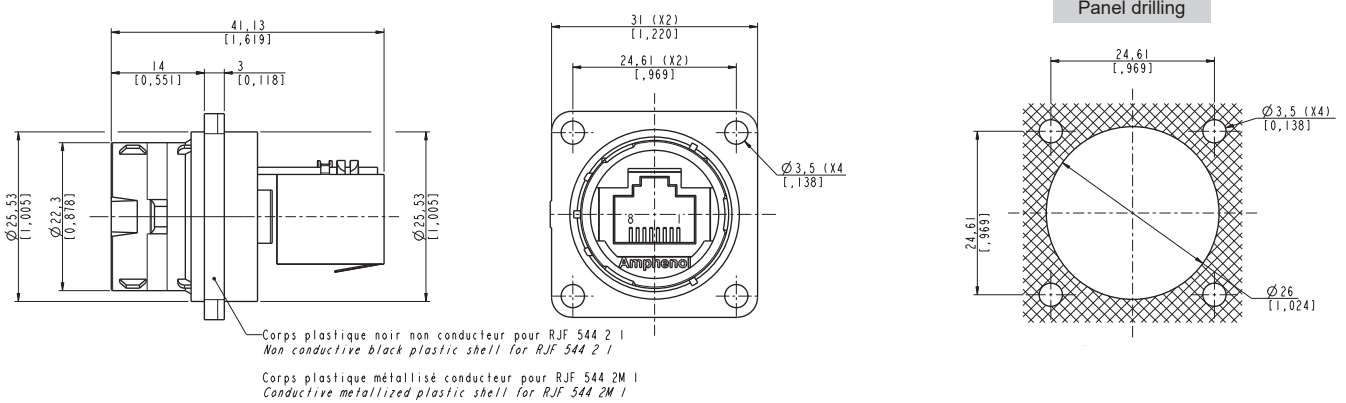

### Receptacle - Square flange receptacle - 4 mounting holes - Shell type 2 - Back termination type 1RA

Part number type (Cat.5e) : **RJF544 2 X 1RA**

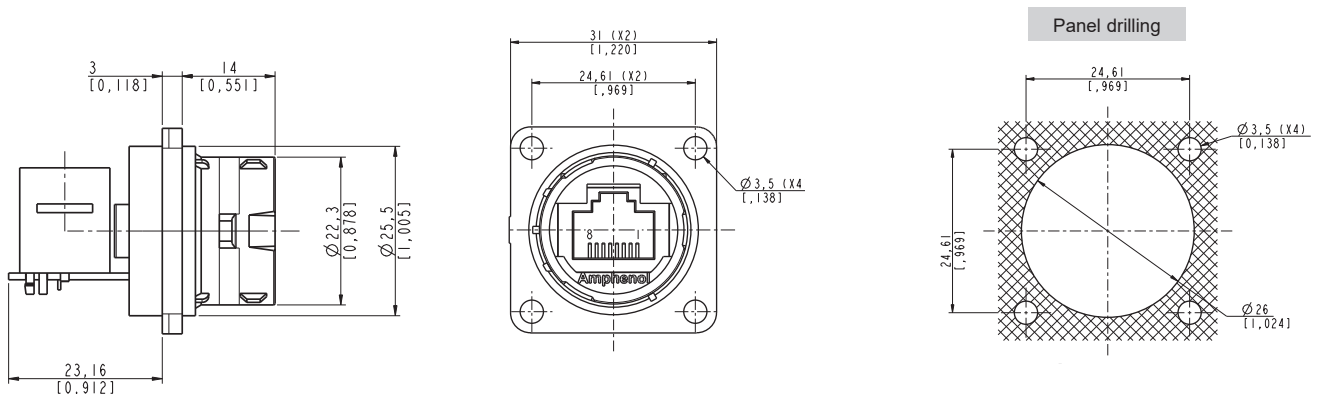



# RJF544

## Overall dimension

Receptacle - Square flange receptacle - 4 mounting holes - Shell type 2 - Bac termination type 2

Part number type (Cat.5e) : **RJF544 2 X 2 XX 100BTX**

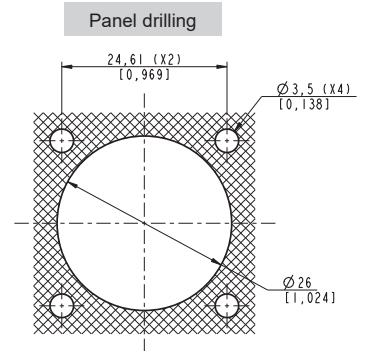
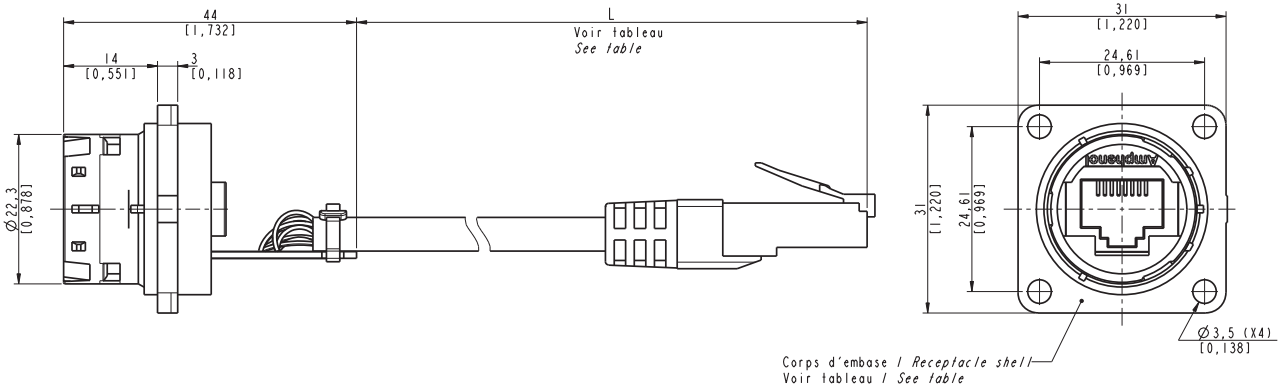

Receptacle - Square flange receptacle - 4 mounting holes - Shell type 2 - Back termination type 00

Part number type (Cat.5e) : **RJF544 2 X 2 00**

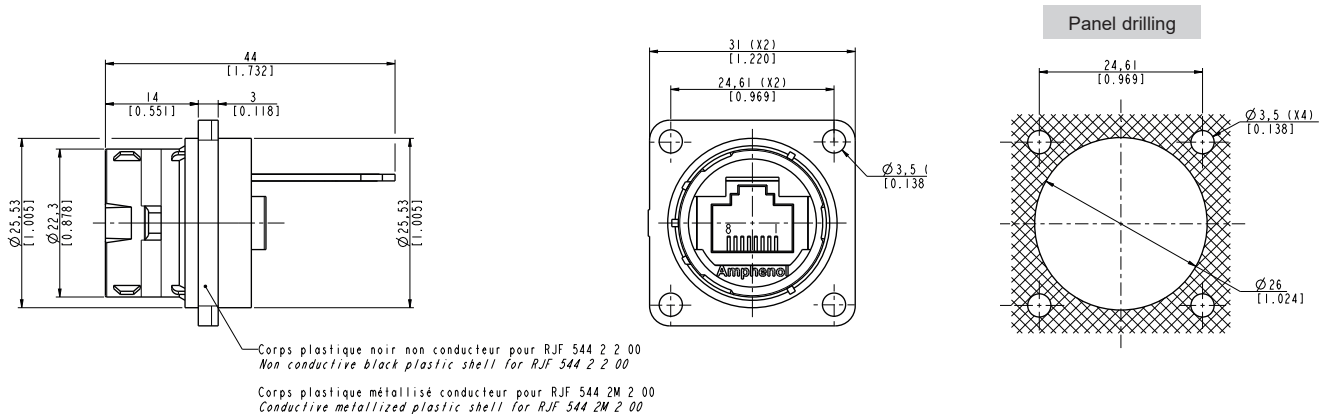



# CABLES AND CORDSETS



## Table of contents

<b>CABLES AND CORDSETS</b>	<b>75</b>
Cat.5e cable and cordset	76
Cat.6 cable and cordset	77
Cat.6A cable and cordset	78
Cat.7 cable and cordset	79
Cat.7 VG95318 cable and cordset	80

# CAT.5E CABLE AND CORDSET



## Description

This Cat.5e cable has been specially selected for fixed or deployable military or industrial application. Can be ordered as cordset with RJ45 at both end or as reel of cable. Its special Polyurethane jacket can withstand the harshest environments.

**How to order :** Please refer to page 122 and 123

## Design

<b>Wire</b>	<b>Conductors</b>	8 x 24 AWG Stranded tinned copper wires (Ø0,6mm)	<b>Overall</b>	Strain member of kevlar
	<b>Insulation</b>	Polyethylene (max Ø1,05mm)		Fillers
	<b>Colors</b>	Pair 1 : White and blue Pair 2 : White and orange Pair 3 : White and green Pair 4 : White and brown		Plastic tapes, overlapped
		4 pairs twisted	<b>Shield 1</b>	Aluminate foil, overlapped
			<b>Shield 2</b>	Tinned copper braid (Ø5,5mm) 80% coverage
			<b>Jacket</b>	<b>Insulation</b>
				<b>Color</b>

## Electrical characteristics at 20°C

<b>Conductor resistance</b>	≤ 96 Ohm/km	<b>Structural Return loss (1 – 20 MHz)</b>	≤ 23 dB	
<b>Resistance difference</b>	3 %	<b>Capacity unbalanced to ground</b>	3400 pF/Km	
<b>Screen resistance</b>	≤ 12 Ohm/km	<b>Characteristic impedance (1 – 100 MHz)</b>	100 ± 15 Ohm	
<b>Insulation resistance</b>	≥ 150 MOhm*km	<b>Operating voltage (peak)</b>	≥ 100 V	
<b>Capacitance (1 kHz)</b>	46 nF/km	<b>Velocity of propagation</b>	81 % nom.	
<b>Signal runtime</b>	≤ 5,2 ns/km	<b>Test voltage (wire/wire/screen rms 50Hz 1min)</b>	700 V	
<b>Delay screw</b>	≤ 20 ns/100m	<b>Attenuation (dB/100m)</b>	1 MHz – 3,15	16 MHz – 12,3
			4 MHz – 6,45	20 MHz – 13,8
			10 MHz – 9,9	100 MHz – 33,0

## Other characteristics

ETL qualified

Halogen Free Flame Retardant

Resistance to microbial/fungus growth acc. IEC60068-2-10 Environmental Testing – Test J degree of mould growth 1

Flame retardant acc. to UL 1581, sec. 1090 (H)

Flame retardant acc. to IEC 60332-1-2

RoHS compliant (Directive 2011/65/EC)

Sunlight resistant acc. to UL444 sec. 7.12

Hydrolysis resistance

Highly flexible

Permissible temperature range for transport and fixed installation : -50°C up to 85°C

Permissible temperature range for installation and flexible use : -40°C up to 85°C

Humidity range : 5 – 93% at 40°C

Maximum pulling force : 800N

Min. bending radius allowed : repeated 8 X Ø single 4 X Ø

Weight : 61 kg/km

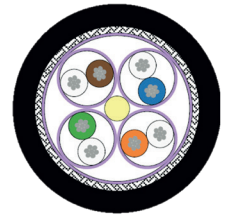

## CAT.6 CABLE AND CORDSET

### Description

This Cat.6 cable has been specially selected for fixed or deployable military or industrial application. Can be ordered as cordset with RJ45 at both end or as reel of cable. Its special Polyurethane jacket can withstand the harshest environments.

**How to order :** Please refer to page 122 and 123

### Design

Wire	Conductors	8 x 26 AWG Stranded tinned copper wires (Ø0,6mm)	Overall	Strain member of kevlar		
	Insulation	Polyethylene (Ø1,0mm)		Plastic tapes, overlapped		
	Shield	Aluminate foil overlapped		Shield 1	Aluminate foil, overlapped	
	Colors	Pair 1 : White and blue		Shield 2	Tinned copper braid (Ø5,3mm) 80% coverage	
Pair 2 : White and orange		Pair 3 : White and green	Jacket	Insulation	Polyurethane (Ø6,9±0,3mm)	
Pair 4 : White and brown	Color			Black – Glossy Finish		
4 screened pairs twisted						

### Electrical characteristics at 20°C

Conductor resistance	≤ 960 Ohm/km	Capacity unbalanced to ground	≤ 1600 pF/Km	
Resistance difference	2 %	Velocity of propagation	72 % nom.	
Screen resistance	≤ 13 Ohm/km	Skew	≤ 45ns/100m	
Signal run time	≈ 4,6 ns/m	Operating voltage (peak)	≤ 100 V	
Insulation resistance	≥ 5 GOhm*km	Test voltage (wire/wire/screen rms 50Hz 1min)	700 V	
Characteristic impedance 100MHz	(100 ±5) Ohm	Attenuation (dB/100m)	1 MHz – 3,1	20 MHz – 12,8
Capacitance (1 kHz)	50 nF/km nom.		4 MHz – 6,45	100 MHz – 29,9
			10 MHz – 9,9	200 MHz – 43,7
			16 MHz – 11,4	250 MHz – 49,7

### Other characteristics

Halogen Free Flame Retardant

Resistance to microbial/fungus growth acc. IEC60068-2-10 Environmental Testing – Test J degree of mould growth 1

Flame retardant acc. to UL 1581, sec. 1090 (H)

Flame retardant acc. to IEC 60332-1-2

RoHS compliant (Directive 2011/65/EC)

Sunlight resistant acc. to UL444 sec. 7.12

Hydrolysis resistance

Highly flexible

Permissible temperature range for transport and fixed installation : -50°C up to 85°C

Permissible temperature range for installation and flexible use : -40°C up to 85°C

Maximum pulling force : 800N

Min. bending radius allowed : repeated 10 X Ø single 5 X Ø

Weight : 55 kg/km



## CAT.6A CABLE AND CORDSET

### Description

This Cat.6A cable has been specially selected for fixed or deployable military or industrial application. Can be ordered as cordset with RJ45 at both end or as reel of cable. Its special Polyurethane jacket can withstand the harshest environments.

**How to order :** Please refer to page 122 and 123

### Design

Wire	Conductors	8 x 26 AWG Stranded tinned copper wires (Ø0,6mm)	Overall	Strain member of kevlar		
	Insulation	Polyethylene (Ø1,0mm)		Plastic tapes, overlapped		
	Shield	Aluminate foil overlapped		Shield 1	Aluminate foil, overlapped	
	Colors	Pair 1 : White and blue		Shield 2	Tinned copper braid (Ø5,3mm) 80% coverage	
Pair 2 : White and orange		Pair 3 : White and green	Jacket	Insulation	Polyurethane (Ø6,9±0,3mm)	
	Pair 4 : White and brown		Color	Black – Glossy Finish		
4 screened pairs twisted						

### Electrical characteristics at 20°C

Conductor resistance	≤ 290 Ohm/km	Capacity unbalanced to ground	≤ 23 dB	
Resistance difference	2 %	Velocity of propagation	3400 pF/Km	
Screen resistance	≤ 13 Ohm/km	Skew	100 ± 15 Ohm	
Signal run time	≈ 4,6 ns/m	Operating voltage (peak)	≥ 100 V	
Insulation resistance	≥ 5 GOhm*km	Test voltage (wire/wire/screen rms 50Hz 1min)	81 % nom.	
Characteristic impedance 100MHz	(100 ±5) Ohm	Attenuation (dB/100m)	1 MHz – 3,1	100 MHz – 28,7
Capacitance (1 kHz)	50 nF/km nom.		4 MHz – 5,7	200 MHz – 41,4
			10 MHz – 8,9	300 MHz – 51,4
			16 MHz – 11,2	400 MHz – 60,1
			20 MHz – 12,6	500 MHz – 67,9

### Other characteristics

Halogen Free Flame Retardant

Resistance to microbial/fungus growth acc. IEC60068-2-10 Environmental Testing – Test J degree of mould growth 1

Flame retardant acc. to UL 1581, sec. 1090 (H)

Flame retardant acc. to IEC 60332-1-2

RoHS compliant (Directive 2011/65/EC)

Sunlight resistant acc. to UL444 sec. 7.12

Hydrolysis resistance

Highly flexible

Permissible temperature range for transport and fixed installation : -50°C up to 85°C

Permissible temperature range for installation and flexible use : -40°C up to 85°C

Maximum pulling force : 800N

Min. bending radius allowed : repeated 10 X Ø single 5 X Ø

Weight : 55 kg/km

# CAT.7 CABLE AND CORDSET

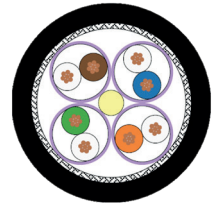

## Description

This Cat.7 cable has been specially selected for fixed or deployable military or industrial application. Can be ordered as cordset with RJ45 at both end or as reel of cable. Its special Polyurethane jacket can withstand the harshest environments.

**How to order :** Please refer to page 122 and 123

## Design

Wire	Conductors	8 x 26 AWG Stranded bare copper wires	Overall	Strain member of kevlar		
	Insulation	Polyethylene (max Ø1,05mm)		Plastic tapes, overlapped		
	Shield	Aluminate foil overlapped		Shield	Tinned copper braid 80% coverage	
	Colors	Pair 1 : White and blue Pair 2 : White and orange Pair 3 : White and green Pair 4 : White and brown			Jacket	Insulation
4 pairs twisted			Color	Black – Glossy Finish		

## Electrical characteristics at 20°C

Loop resistance	≤ 290 Ohm/km	Screening attenuation 30 – 600 MHz	≥ 90 dB	
Screen resistance	≤ 10 Ohm/km	Operating voltage (peak)	≤ 100 V	
Signal run time	≈ 5,3 ns/m	Test voltage (wire/wire/screen rms 50Hz 1min)	700 V	
Insulation resistance	≥ 500 MOhm*km	Attenuation (dB/100m)	1 MHz – 3,1	100 MHz – 28,7
Characteristic impedance 100MHz	(100 ±5) Ohm		4 MHz – 5,7	200 MHz – 41,4
			10 MHz – 8,9	300 MHz – 51,4
			16 MHz – 11,2	400 MHz – 60,1
			20 MHz – 12,6	500 MHz – 67,9

## Other characteristics

Halogen Free Flame Retardant

Resistance to microbial/fungus growth acc. IEC60068-2-10 Environmental Testing – Test J degree of mould growth 1

Flame retardant acc. to UL 1581, sec. 1090 (H)

Flame retardant acc. to IEC 60332-1-2

RoHS compliant (Directive 2011/65/EC)

Sunlight resistant acc. to UL444 sec. 7.12

Hydrolysis resistance

Highly flexible

Permissible temperature range for transport and fixed installation : -50°C up to 85°C

Permissible temperature range for installation and flexible use : -40°C up to 85°C

Maximum pulling force : 800N

Min. bending radius allowed : repeated 10 X Ø single 5 X Ø

Weight : 54 kg/km



## CAT.7 VG95318 CABLE AND CORDSET

### Description

This Cat.7 cable has been specially selected for fixed or deployable military or industrial application. Can be ordered as cordset with RJ45 at both end or as reel of cable. Its special Polyurethane jacket can withstand the harshest environments. Moreover, this Cat.7 cable is VG95318 approved.

**How to order :** Please refer to page 122 and 23

### Design

Wire	<b>Conductors</b>	8 x 26 AWG Stranded bare copper wires	<b>Overall</b>	Strain member of kevlar
	<b>Insulation</b>	Polyethylene (max Ø1,05mm)		Plastic tapes, overlapped
	<b>Shield</b>	Aluminate foil overlapped	<b>Shield</b>	Tinned copper braid 80% coverage
	<b>Colors</b>	Pair 1 : White and blue Pair 2 : White and orange Pair 3 : White and green Pair 4 : White and brown		<b>Jacket</b>
4 pairs twisted		<b>Color</b> Black		

### Electrical characteristics at 20°C

<b>Loop resistance</b>	≤ 290 Ohm/km	<b>Screening attenuation 30 – 600 MHz</b>	≥ 90 dB	
<b>Screen resistance</b>	≤ 10 Ohm/km	<b>Transfer impedance of screen (1 - 30 MHz)</b>	≤ 10 Ohm/km	
<b>Signal run time</b>	≈ 5,3 ns/m	<b>Operating voltage (peak)</b>	≤ 100 V	
<b>Insulation resistance</b>	≥ 15 GOhm*km	<b>Test voltage (wire/wire/screen rms 50Hz 1min)</b>	700 V	
<b>Characteristic impedance 100MHz</b>	(100 ±5) Ohm	<b>Attenuation (dB/100m)</b>	1 MHz – 2,9	100 MHz – 27,8
			4 MHz – 5,5	155 MHz – 35,0
			10 MHz – 8,5	200 MHz – 40,1
			16 MHz – 10,8	300 MHz – 50,0
			20 MHz – 12,1	600 MHz – 73,3

### Other characteristics

Acc. to VG 95218-31 type B

RoHS compliant (Directive 2011/65/EC)

Sunlight resistant acc. to UL444 sec. 7.12

Smoke-density acc. to IEC 61034-2

Halogen Free

Permissible temperature range for transport and fixed installation : -40°C up to 85°C

Permissible temperature range for installation and flexible use : -40°C up to 85°C

Maximum pulling force : 800N

Min. bending radius allowed : repeated 8 X Ø single 4 X Ø

Weight : 46 kg/km



# CABLE ASSEMBLY AND HANESSES

## Description

We have the capabilities to supply complete solution of cable assemblies, harnesses, military cable reel and deployment system. Please consult us to define together your project.

## Example of configuration

### Armored ethernet cable

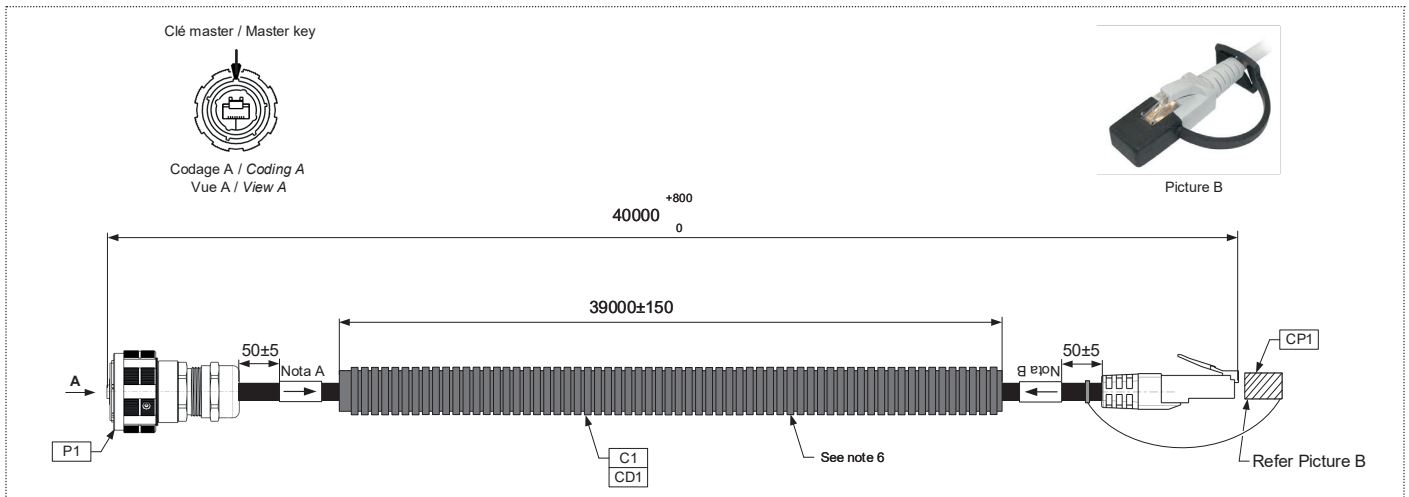

### Deport touret

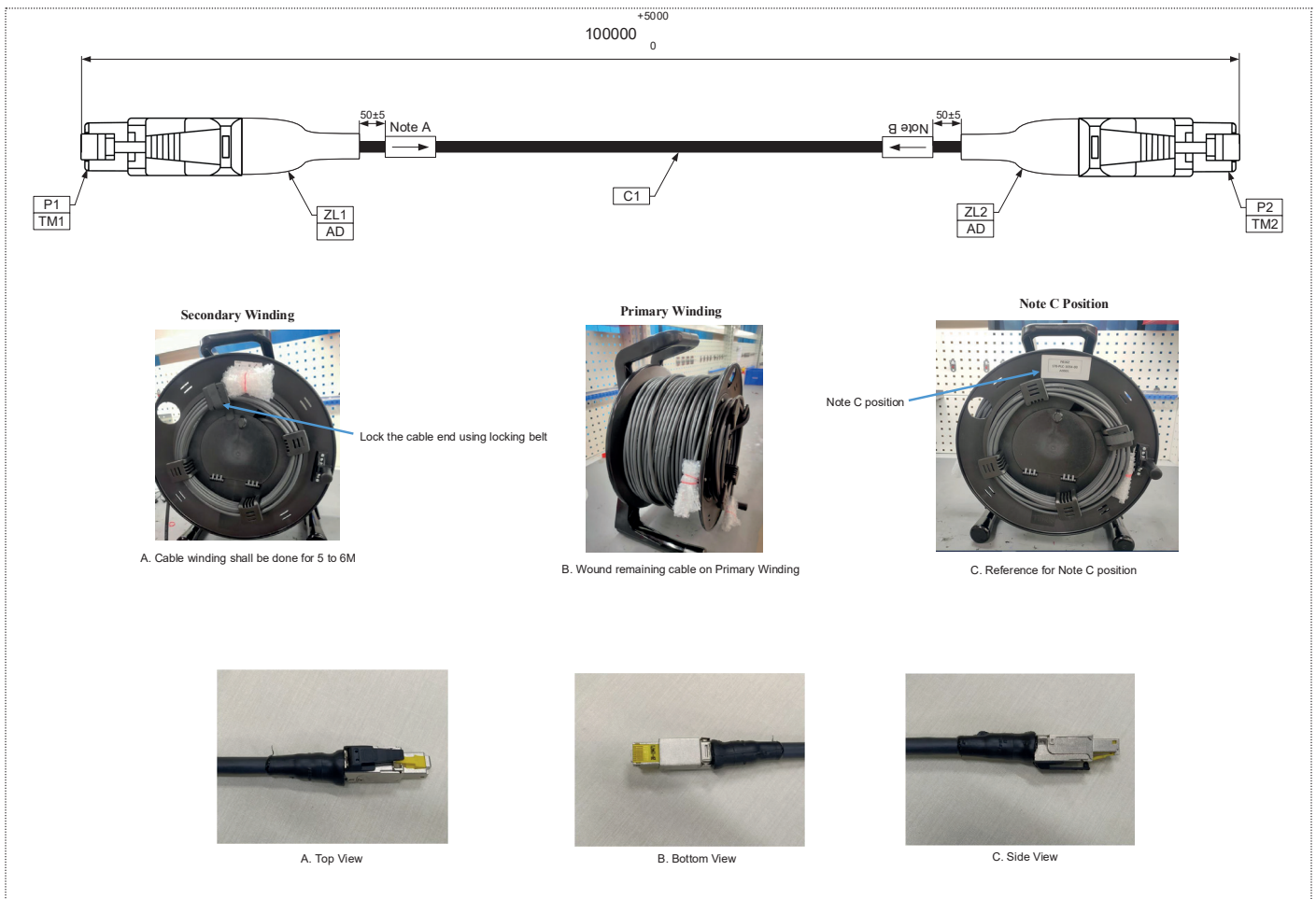

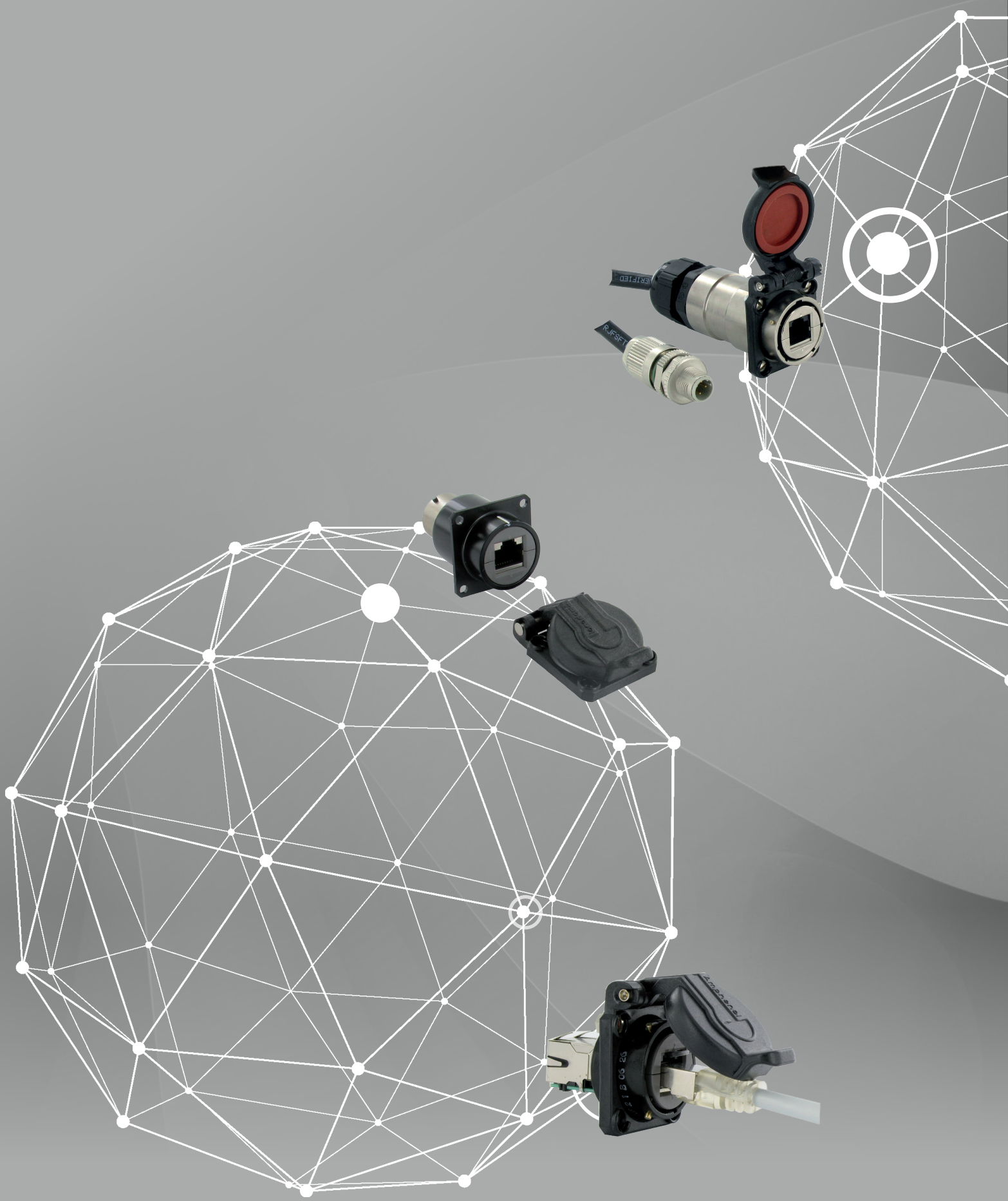

# ADAPTORS AND ACCESS POINTS



## Table of contents

<b>ADAPTORS AND ACCESS POINTS</b>	<b>83</b>
RJ45 access point	84
RJ11 to type EN3646 - PT/451 - ABS1547 adaptor	85
RJ45 to type EN3646 - PT/451 - ABS1547 adaptor	86
RJ45 to M12 adaptor	87
RJFTV™ intercoach jumper	89

# RJ45 ACCESS POINT



## Description

This kit includes a receptacle and a Self Closing Cap which protects the RJF™ square flange receptacles (MIL-DTL-26482 type). This cap offers a protection against dust and water projections. A spring automatically closes the upper part of the cap when either the RJF plug or RJ45 cordset are removed from the receptacle.

## Overall dimension

RJ45 Access point - With self-closing cap

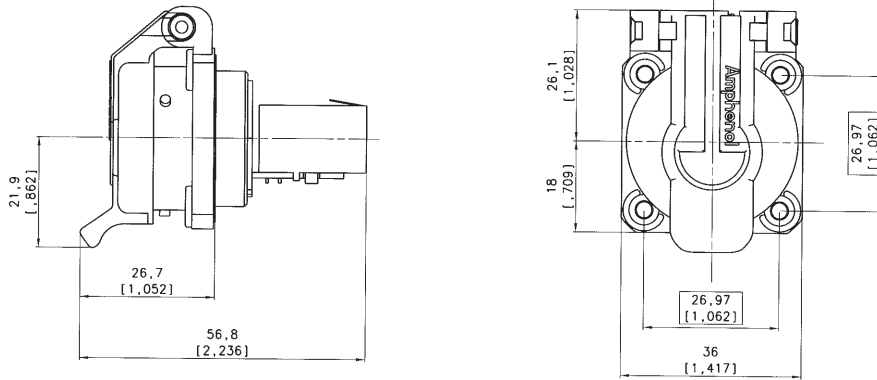

Data transmission	Part number	Plating	Metallized insert
Cat.5e	RJF 2 1 B SCC	Black coating ✓	No
	RJF 2 1 N SCC	Nickel ✓	No
	RJF 2 1 G SCC	Olive drab cadmium	Yes
	RJF 2 1 ZN SCC	Black Zinc Nickel ✓	Yes

✓ : RoHS compliant

Metal range  
Composite range  
Cables and cordsets  
Adaptors and access points  
Accessories  
Assembly instructions  
How to order

# RJ11 TO TYPE EN3646 - PT/451 - ABS1547 ADAPTOR



## Description

At the rear of the adaptor, the connection in for connector type EN3646 and PT/451. This adaptor is qualified ABS1547.

## Overall dimension

RJ11 adaptor to EN3646 - PT/451 with 12-8 arrangement - With or without self-closing cap

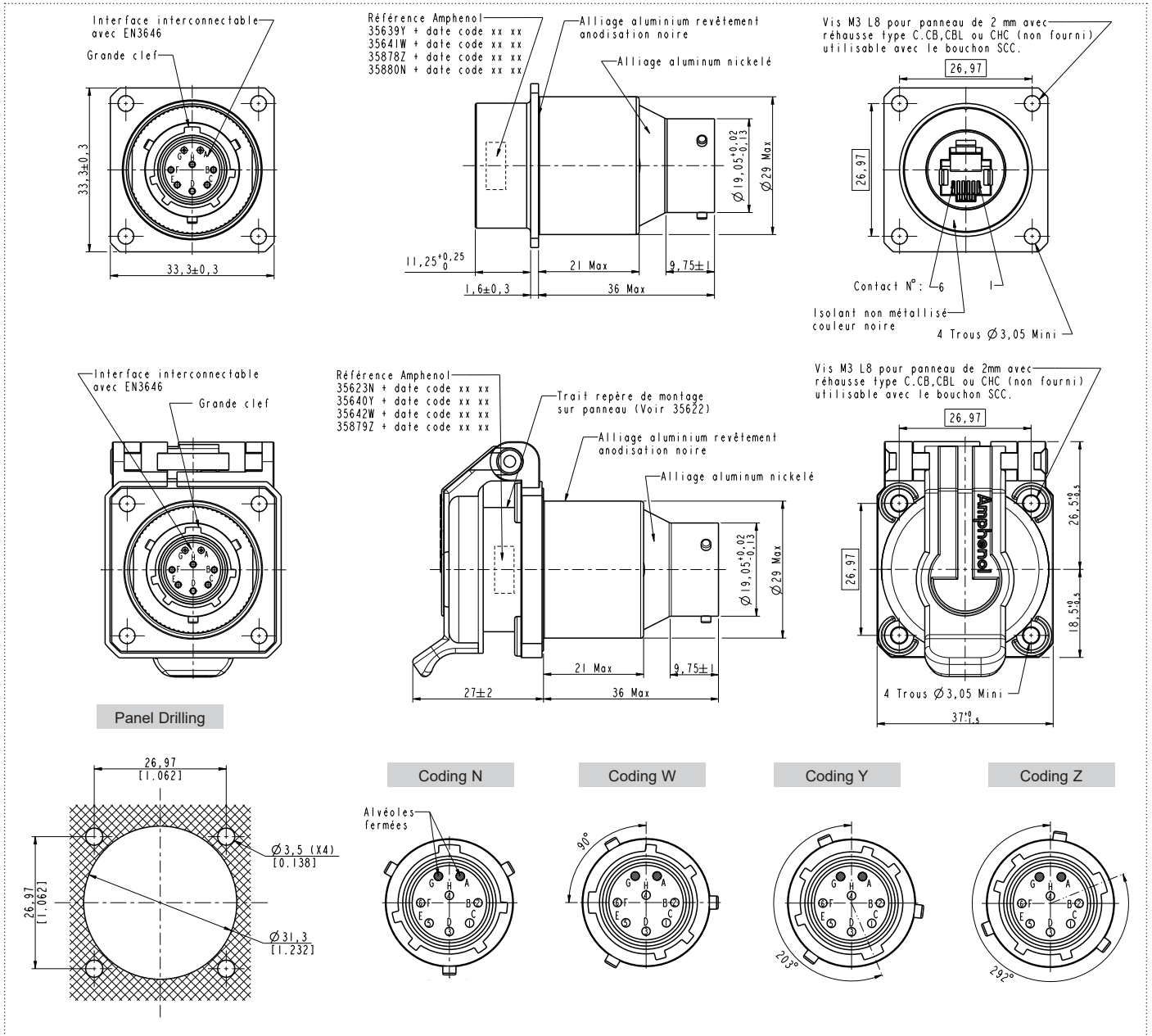

Part number	ABS1547 part number	Coding	Self-closing cap
35880	ABS1547-003C02N	N	
35641	ABS1547-003C02W	W	
35639	ABS1547-003C02Y	Y	No
35878	ABS1547-003C02Z	Z	
35623	ABS1547-003C01N	N	
35640	ABS1547-003C01W	Y	
35642	ABS1547-003C01Y	W	Yes
35879	ABS1547-003C01Z	Z	

Due to technical modifications, all information provided is subject to change without prior notice  
Designed by Amphenol Socapex

# RJ45 TO TYPE EN3646 - PT/451 - ABS1547 ADAPTOR

## Description

At the rear of the adaptor, the connection is for connectors type EN3646 and PT/451. This adaptor is qualified ABS1547.

## Overall dimension

RJ45 adaptor to EN3646 - PT/451 with 12-10 arrangement - With or without self-closing cap

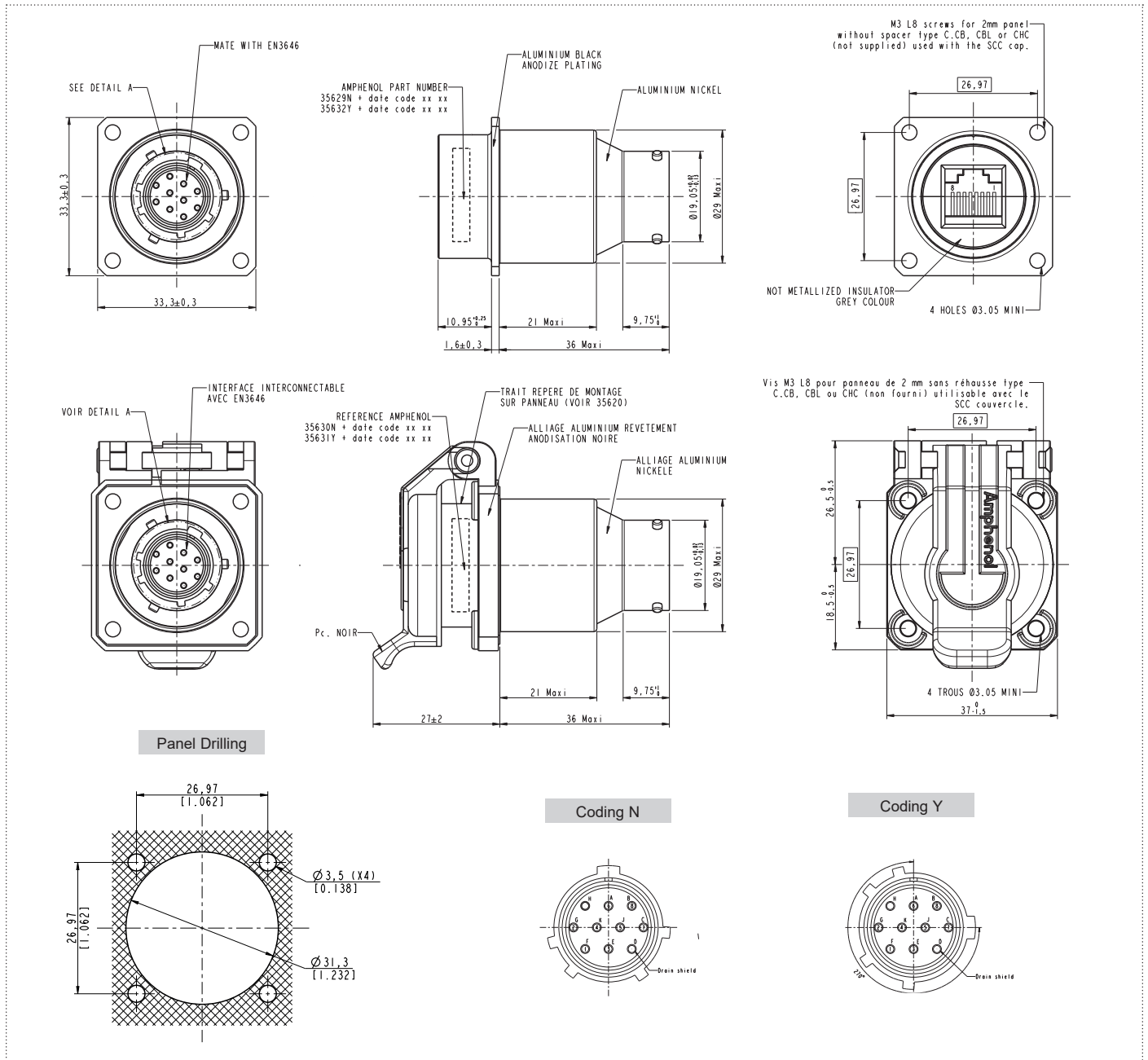

# RJ45 TO M12 ADAPTOR



## Description

RJ45/M12 adaptors provide an access point with RJ45 on M12, D coded based networks. Especially used in Rail Mass Transit applications.

## Overall dimension

RJ45 Adaptor / M12 - With self-closing cap or standard cap

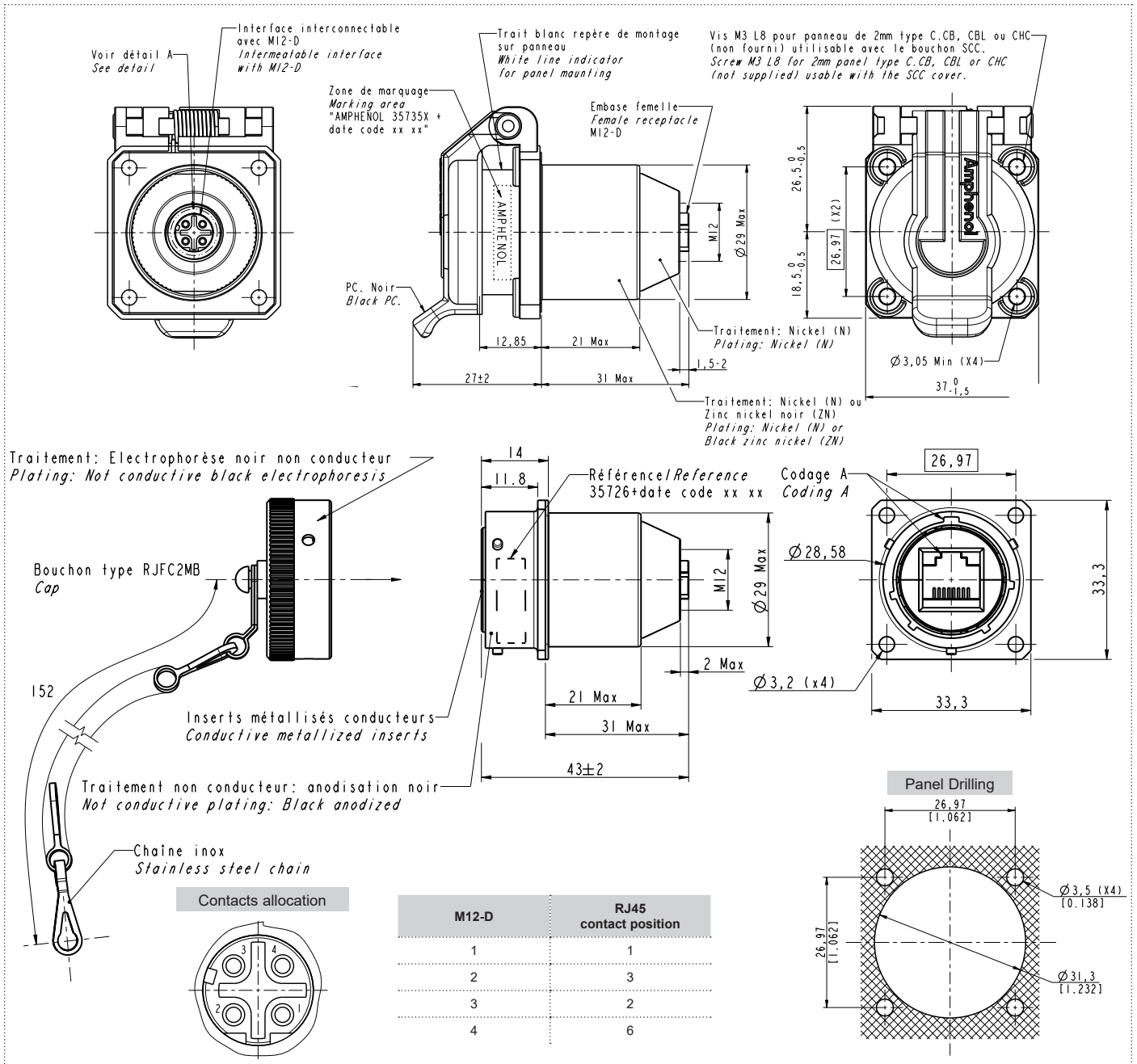

Part number	Insert	Plating	Cap
35655	Plastic	Black anodized ✓	Self-closing cap
35735N		Nickel ✓	
35735ZN	Metallised	Black Zinc Nickel ✓	Standard cap
35726		Black anodized ✓	

✓ : RoHS compliant

# RJ45 TO M12 ADAPTOR

## Description

Kit for maintenance connection RJ45/M12D coded based networks. Especially used in Rail Mass Transit applications.

## Overall dimension

RJ45 Adaptor / M12 cable - With self-closing cap

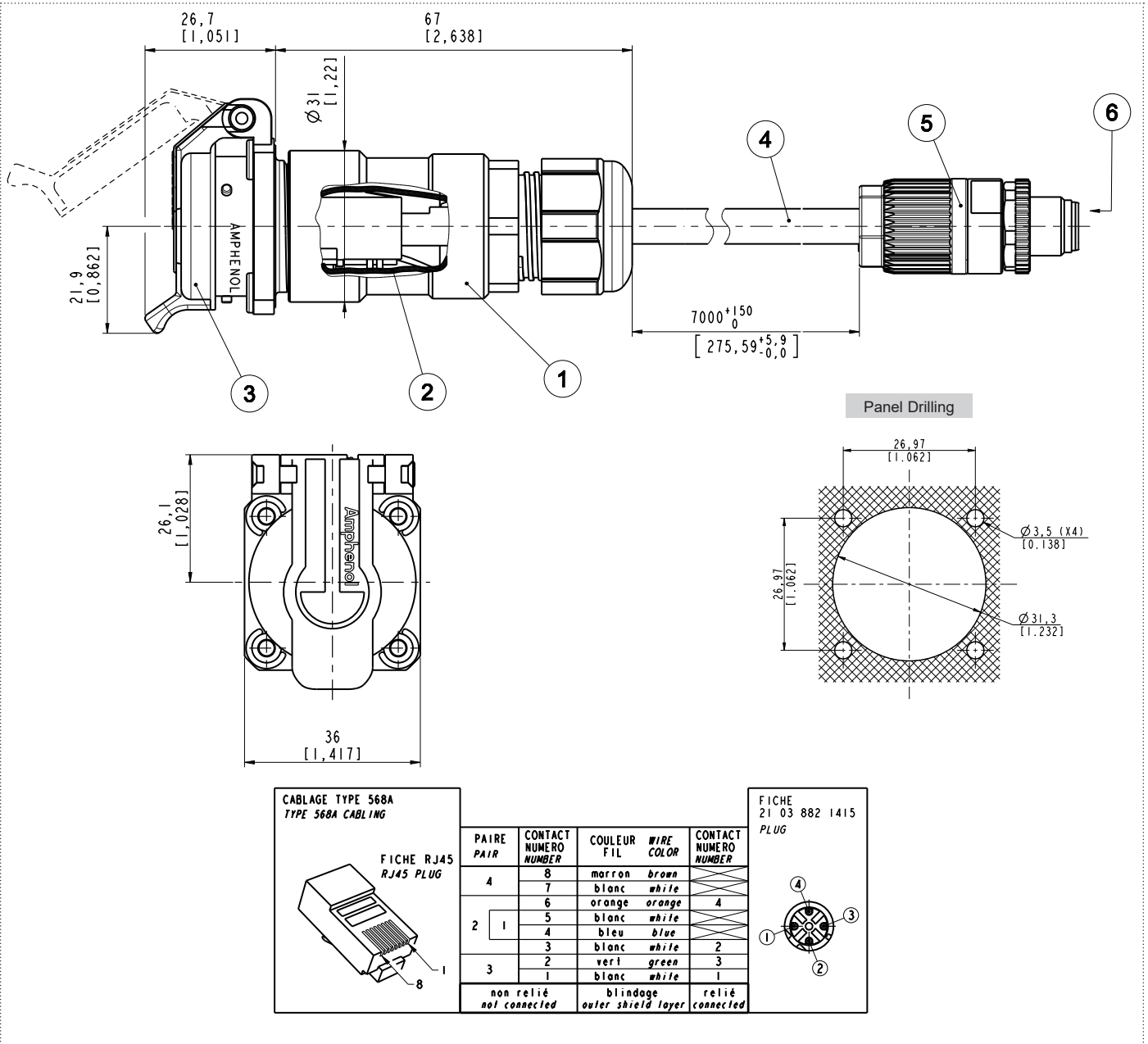

Part number	Length (mm)
<b>KIT36520</b>	1 000
<b>KIT36565</b>	2 000
<b>KIT36530</b>	4 000
<b>KIT36517</b>	5 000
<b>KIT36516</b>	7 000



# RJFTV™ INTERCOACH JUMPER

## Description

This kit is specially designed for Rail Mass Transit intercoach jumper. It is composed of a conduit around a Cat.5e cable with at each end a RJFTV plug with a specific backshell. Especially used in Rail Mass Transit applications.

## Overall dimension

### RJTV™ Jumper

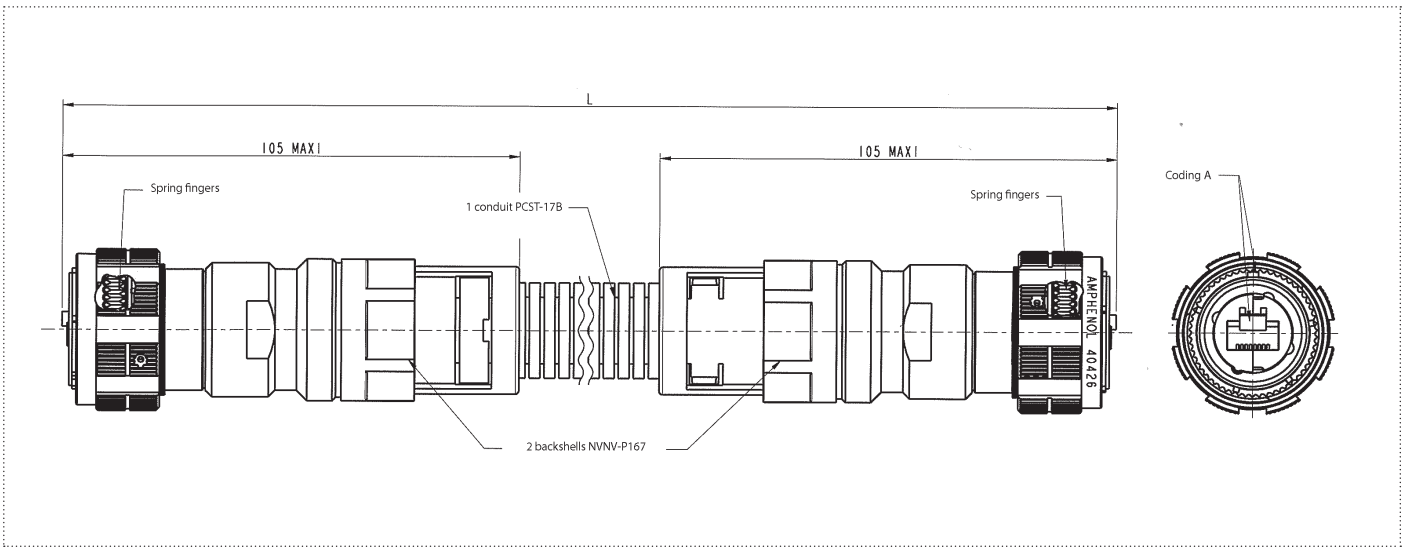

Data transmission	Part number	+100 L 0
Cat.5e	Kit 40426 Rep 101	2465
	Kit 40426 Rep 102	3010

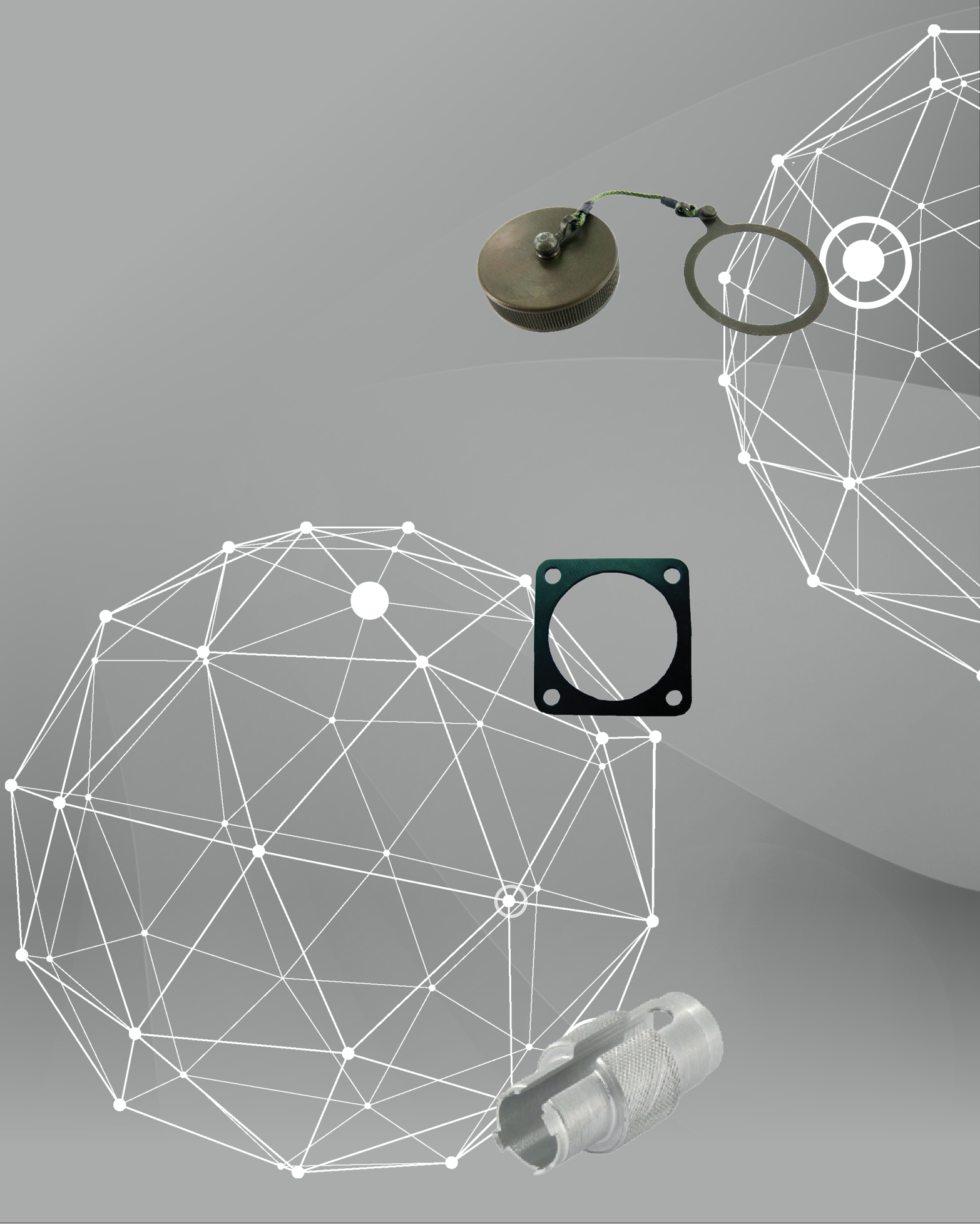

# ACCESSORIES



## Table of contents

ACCESSORIES	91
Standard protective cap - RJF™	92
Standard protective cap - RJFTV™	93
Standard protective cap - RJ11F	94
Standard protective cap - RJ11FTV	95
Self-closing cap - RJF™	96
Self-closing cap - RJFTV™	97
Standard protective cap - RJFRB and RJF544	98
Panel gasket and tool	99

## Compatibility table

	RJF™	RJFTV™	RJ11F	RJ11FTV	RJFRB	RJF544
STANDARD PROTECTIVE CAP	RJF C	RJFTV C	RJ11F C	RJ11FTV C	RJFRB C	RJF544 BESC RJF544 02BM
REDUCED FLANGE PROTECTIVE CAP	/	RJFTV C F057	/	/	/	/
COMPOSITE SELF-CLOSING CAP	RJF SCC	/	PT SCC 14	/	/	/
METALLIC SELF-CLOSING CAP	/	RJFTV SCC	/	/	/	/
PANEL GASKET	JE 18	JE 19	JE 14	/	/	RJF544 02JE
TOOL	RJF ODE	RJF ODE	RJ11F ODE	/	/	/
REDUCED FLANGE TOOL	/	809686	/	/	/	/

# STANDARD PROTECTIVE CAP - RJF™



## Overall dimension

### RJF™ protective cap

Part number: RJF C 6 X

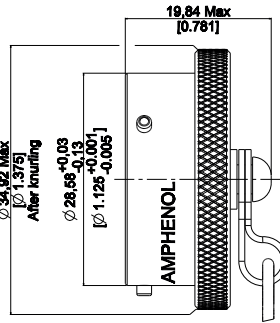

Part number: RJF C 2 X or RJF C 7 X

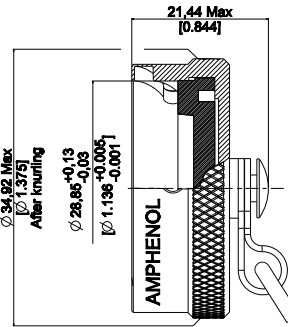

Small ring for square flange receptacle

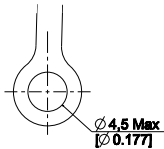

Large ring for jam nut receptacle

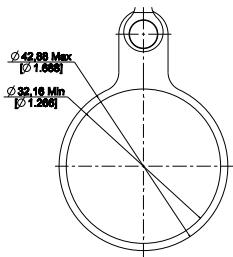

Tie wrap for plug cap

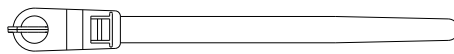

Metallic chain

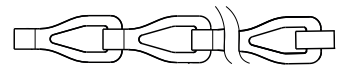

Stainless steel rope

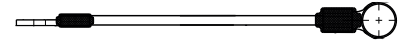

Nylon rope

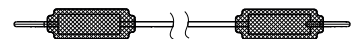

Cap type	Metallic chain length (mm)	Nylon cord length (mm)	Stainless steel rope length (mm)
RJF C 2 & RJF C 7		105±5	
RJF C 6		160±5	

**How to order :** Please refer to page 124

✓ : RoHS compliant

# STANDARD PROTECTIVE CAP - RJFTV™



## Overall dimension

### RJFTV™ protective cap

Part number: **RJFTV C 6 X**

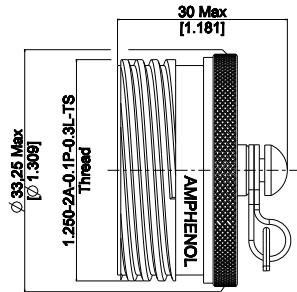

Part number: **RJFTV C 2 X or RJFTV C 7 X**

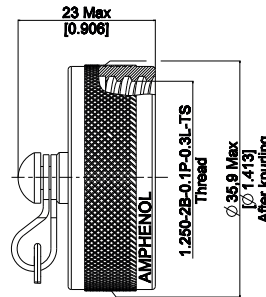

Small ring for square flange receptacle

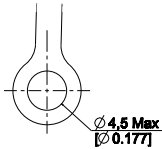

Tie wrap for plug cap



Metallic chain



Large ring for jam nut receptacle

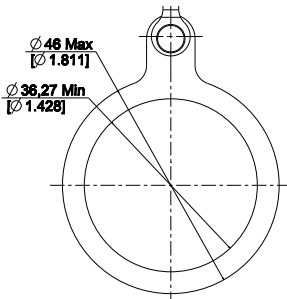

Ring for reduced flange jam nut receptacle

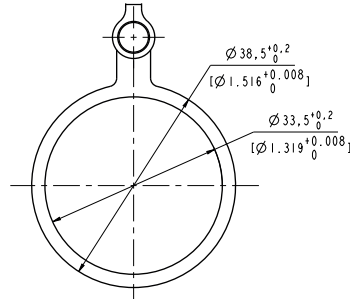

Stainless steel rope

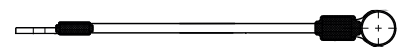

Nylon rope

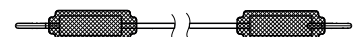

Cap type	Metallic chain length (mm)	Nylon cord length (mm)	Stainless steel rope length (mm)
RJFTV C 2 & RJFTV C 7		127 <sup>+13</sup> <sub>-7</sub>	
RJFTV C 6		160±5	

**How to order :** Please refer to page 124

✓ : RoHS compliant

# STANDARD PROTECTIVE CAP - RJ11F

## Overall dimension

### RJ11F protective cap

Part number: **RJ11F C 6 X**

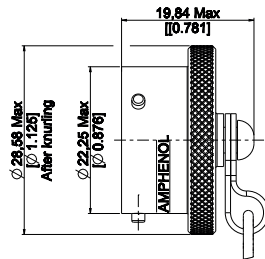

Part number: **RJ11F C 2 X or RJ11F C 7 X**

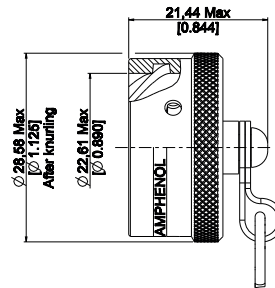

Small ring for square flange receptacle

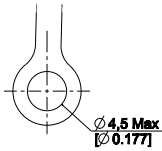

Large ring for jam nut receptacle

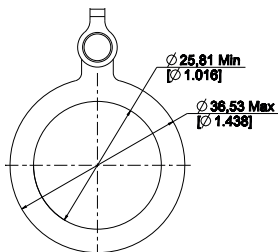

Tie wrap for plug cap

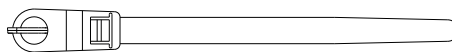

Stainless steel rope

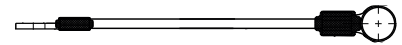

Cap type	Metallic chain length (mm)	Nylon cord length (mm)	Stainless steel rope length (mm)
RJ11F C 2 & RJ11F C 7		105±5	
RJ11F C 6		160±5	

**How to order :** Please refer to page 124

✓ : RoHS compliant

# STANDARD PROTECTIVE CAP - RJ11FTV

## Overall dimension

### RJ11F TV protective cap

Part number: **RJ11FTV C 6 X**

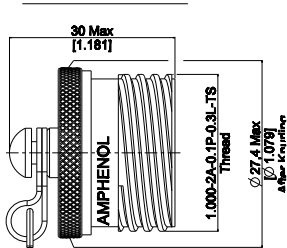

Part number: **RJ11FTV C 2 X or RJ11FTV C 7 X**

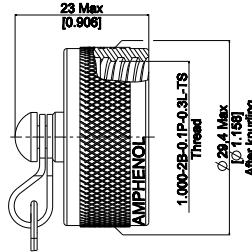

Small ring for square flange receptacle

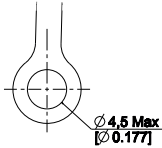

Large ring for jam nut receptacle

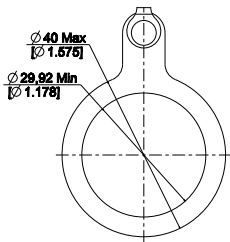

Tie wrap for plug cap

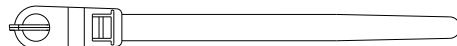

Metallic chain

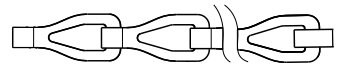

Stainless steel rope

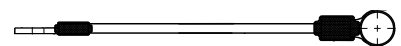

Nylon rope

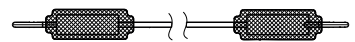

Cap type	Metallic chain length (mm)	Nylon cord length (mm)	Stainless steel rope length (mm)
RJ11FTV C 2 & RJ11FTV C 7		127 <sup>+13</sup> -7	
RJ11FTV C 6		160±5	

**How to order** : Please refer to page 124

✓ : RoHS compliant

# SELF-CLOSING CAP - RJF™



## Overall dimension

### RJF™ composite self-closing cap

Part number type : RJF SCC

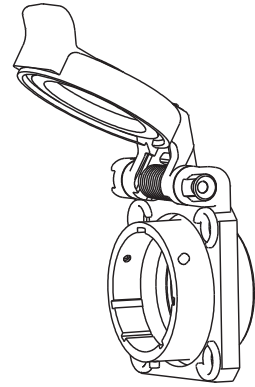
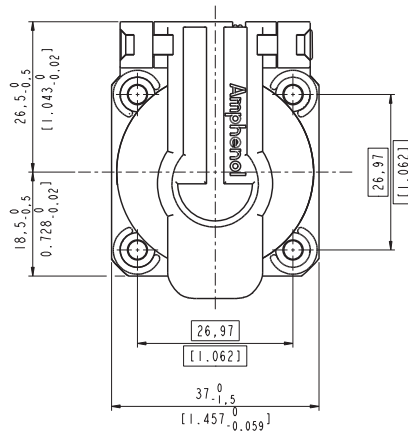
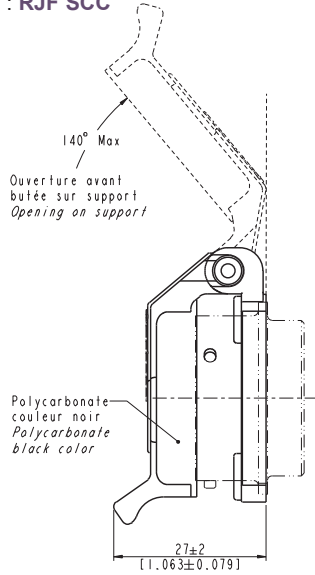

Part number type : PT SCC 14

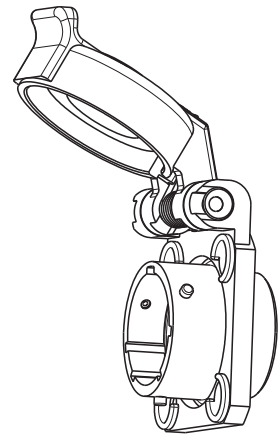
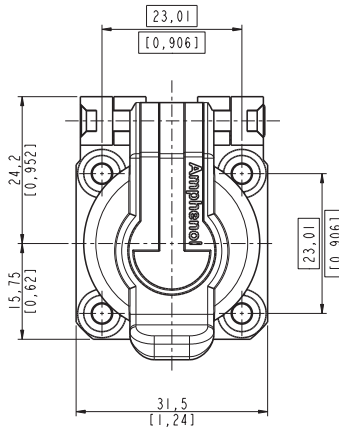
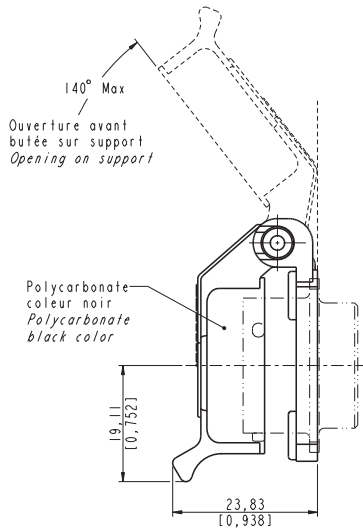

✓ : RoHS compliant



# SELF-CLOSING CAP - RJFTV™



## Metallic Self-closing cap

### RJFTV™ Self-closing cap

Part number type : RJFTV SCC X

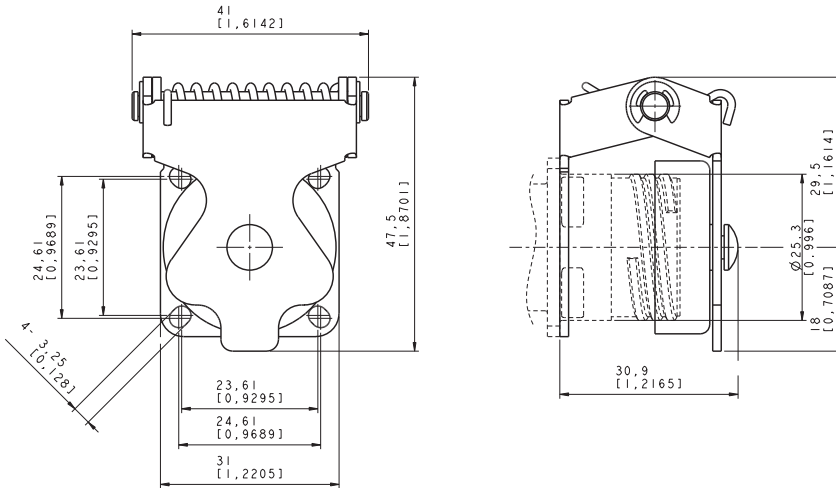

Part number type: RJFTV 7 SCC X

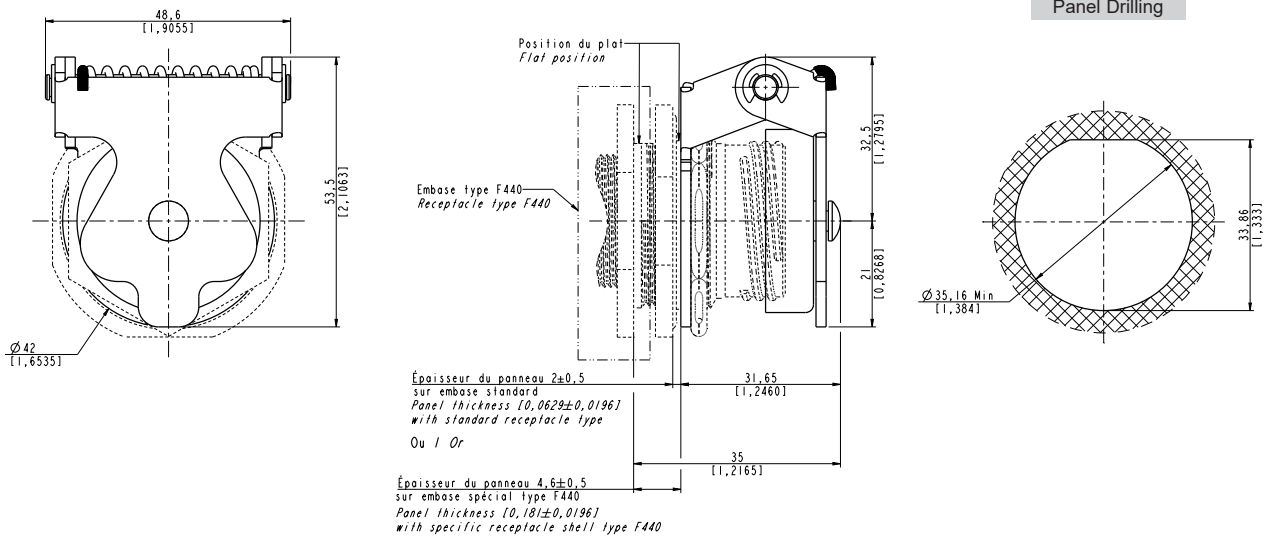

## How to order

Square flange receptacle	Jam nut receptacle	Plating
RJFTV SCC B	RJFTV 7 SCC B	Black coating ✓
RJFTV SCC N	RJFTV 7 SCC N	Nickel ✓
RJFTV SCC G	RJFTV 7 SCC G	Olive drab cadmium
RJFTV SCC ZN	RJFTV 7 SCC ZN	Black zinc nickel ✓

✓ : RoHS compliant

# STANDARD PROTECTIVE CAP - RJFRB AND RJF544



## Overall dimension

### RJFRB protective cap for receptacle

Part number type: **RJFRB C7**

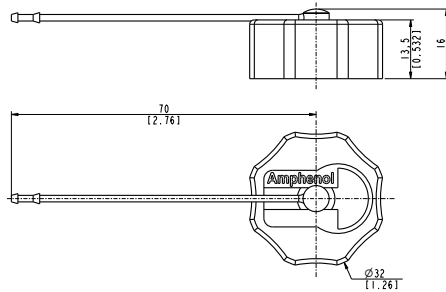

Part number type: **RJFRB C75**

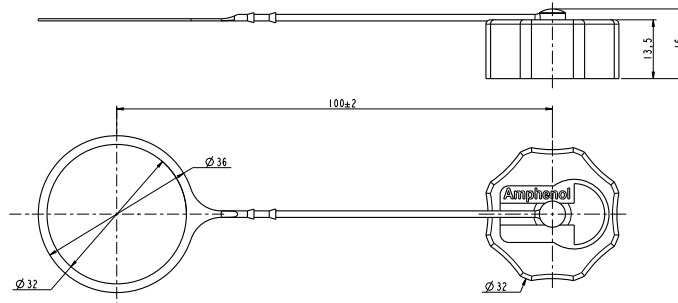

### RJF544 rubber cap for receptacle

Part number type: **RJF544 BESC**

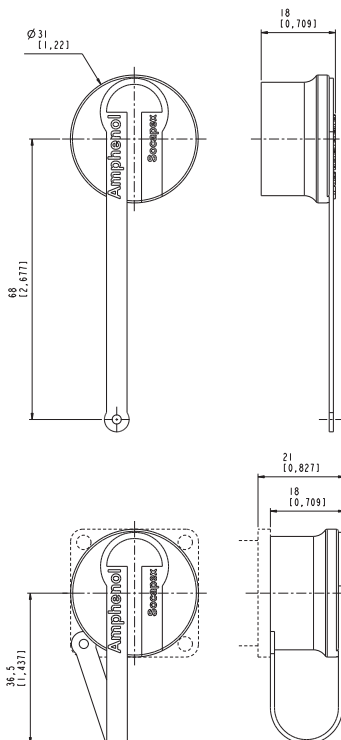

### RJF544 rubber cap for plug



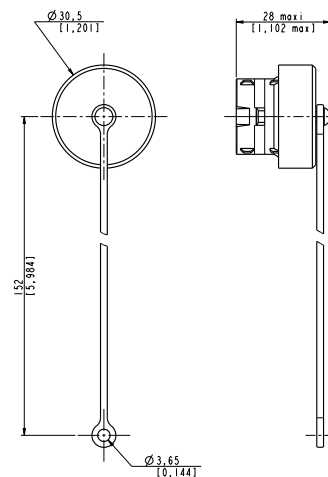

Part number type: **RJF544 BM**



Metal range  
Composite range  
Cables and cordsets  
Adaptors and access points  
Accessories  
Assembly instructions  
How to order

# PANEL GASKET AND TOOL

## Panel gasket for square flange receptacle

Part number	Corresponding receptacle	Thickness (mm)	Color	Picture
JE14	RJ11F	0.6	Black	
JE18	RJF™	0.6	Black	
RJF54402JE	RJF544	0.6	Black	
JE19	RJFTV™	0.8	Blue	

## Tool

Part number : RJF ODE

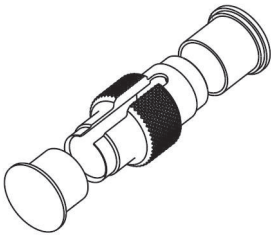

**Important note:**

- RJF ODE is used to dismount the RJStop of the plug. Insert the four teeth face part of the RJF ODE part into the front of the plug and push.
- RJF ODE is used to remove the module of the receptacle. Insert the slot face part of the RJF ODE part into the front of the receptacle and push.
- For more details, please refer to "Assembly instructions" page 102 and 104.

Part number : RJF11 ODE

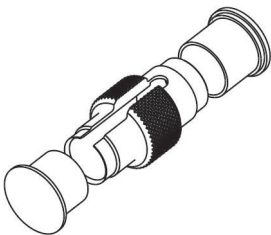

**Important note:**

- RJF ODE is used to dismount the RJStop of the plug. Insert the slot face part of the RJF ODE part into the front of the plug and push.
- RJF ODE is used to remove the module of the receptacle. Insert the complete face part of the RJF ODE part into the front of the receptacle and push.
- For more details, please refer to "Assembly instructions" page 103.

Part number : 809686

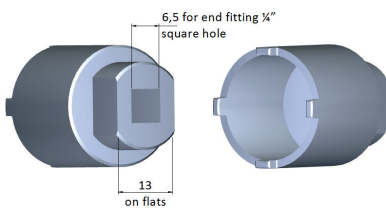

**Important note:**

- This tool is used to tighten the castle nut of the reduced flange receptacle.
- Insert the four teeth face of the tool into the castle nut and tighten at the recommended force.
- For more details, please refer to "Assembly instructions" page 104.

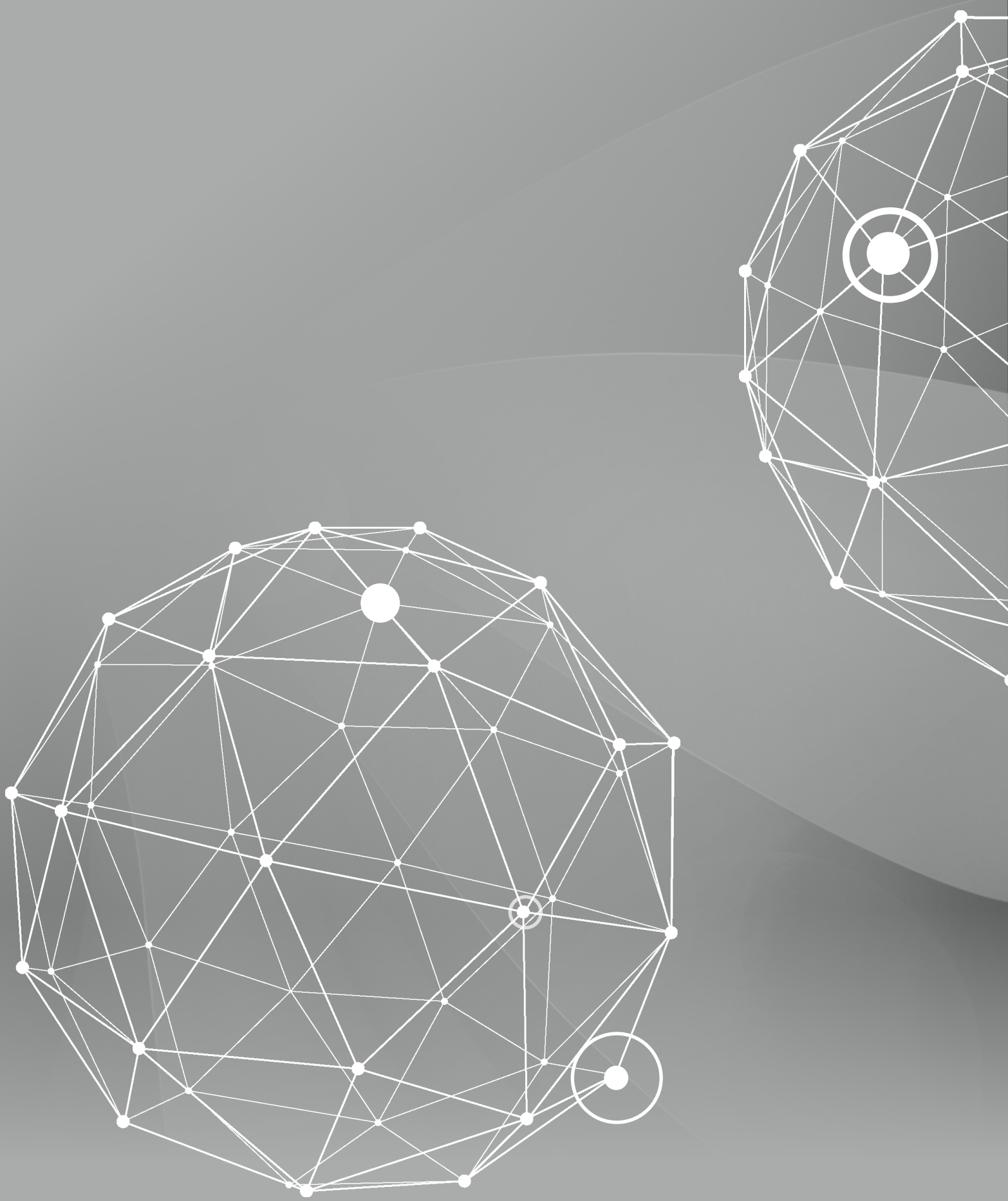

# ASSEMBLY INSTRUCTION

## Table of contents

<b>ASSEMBLY INSTRUCTION</b>	<b>101</b>
RJF™	102
RJ11F	103
RJFTV™	104
RJFRB	105
RJF544	106

Metal range

Composite range

Cables and cordsets

Adaptors and access points

Accessories

Assembly instructions

How to order

# ASSEMBLY INSTRUCTION - RJF™

Metal range  
Composite range  
Cables and cordsets  
Adaptors and access points  
Accessories  
Assembly instructions  
How to order

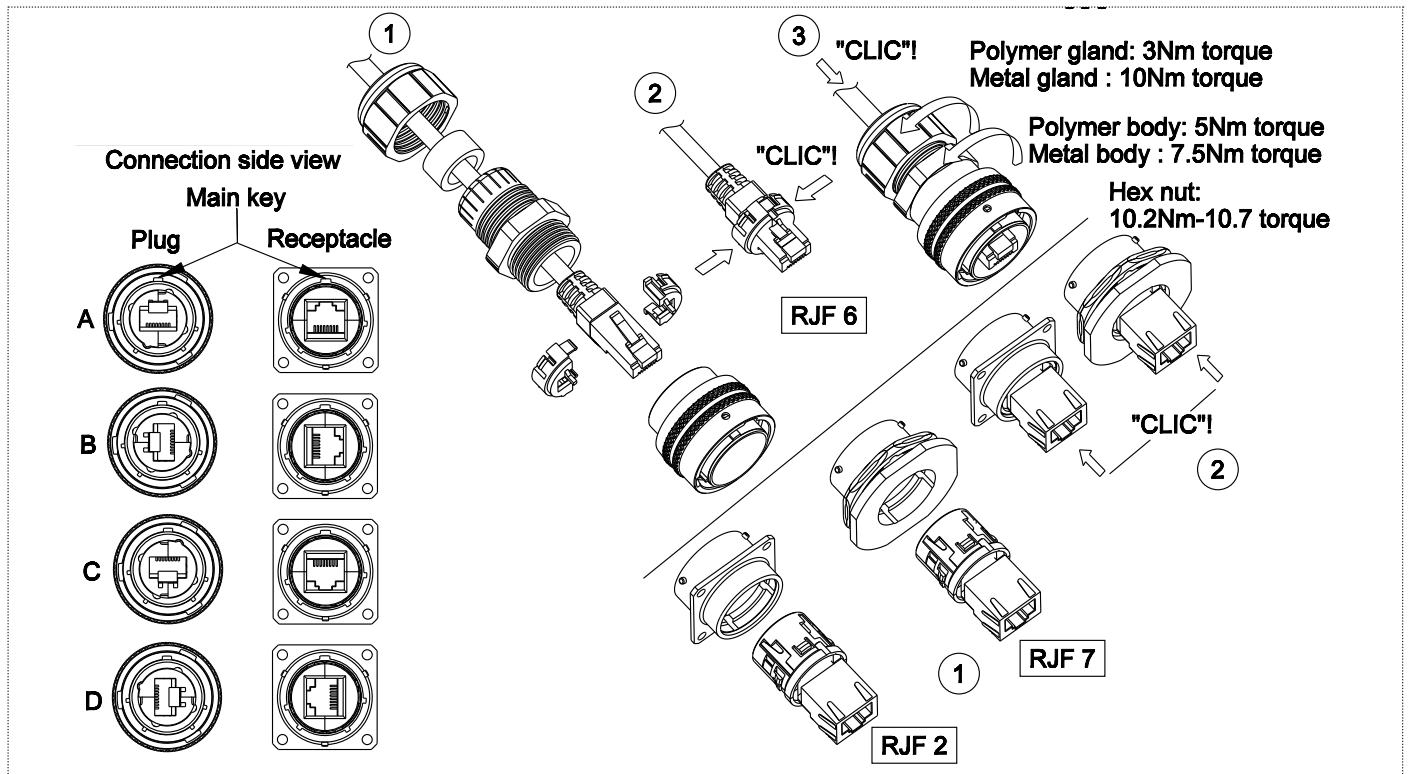

**Important note:**

- Can be assembled with all standard RJ45 cordset.
- No tool required for assembly.
- Choose your coding on plug side during the assembly. The standard coding on receptacle side is A. To change this coding use the removal tool. Please refer to page 99.

**Recommend Torque value:**

		Extender	Body	Plastic Gland	Metal Gland	Hex-nut
Plug	RJF 6	/	5.0 Nm	3.0 Nm	/	/
	RJF 6M	/	7.5 Nm	/	10.0 Nm	/
Receptacle	RJF 2 PE	5.0 Nm	5.0 Nm	3.0 Nm	/	/
	RJF 2 PEM	7.5 Nm	10.0 Nm	/	10.0 Nm	/
	RJF 7	/	/	/	/	10.2 to 10.7 Nm
	RJF 7 PE	5.0 Nm	5.0 Nm	3.0 Nm	/	10.2 to 10.7 Nm
	RJF 7 PEM	7.5 Nm	10.0 Nm	/	10.0 Nm	10.2 to 10.7 Nm

## Assembly video





See our assembly video on youtube :  
[www.youtube.com/AmphenolSocapex](http://www.youtube.com/AmphenolSocapex)

- Amphenol RJ Field Assembly - Rugged RJ45 connector

# ASSEMBLY INSTRUCTION - RJ11F

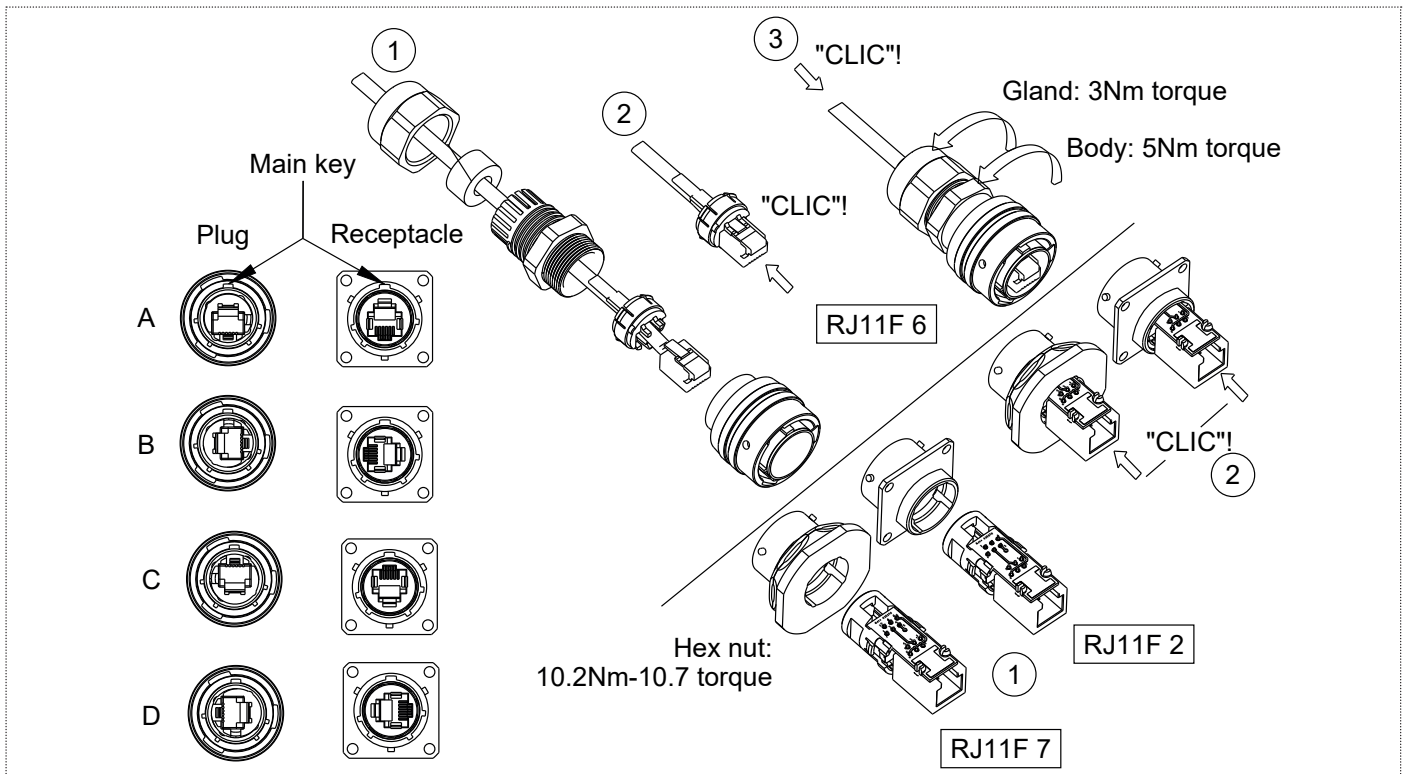

**Important note:**

- Can be assembled with all standard RJ11 cordset.
- No tool required for assembly.
- Choose your coding on plug side during the assembly. The standard coding on receptacle side is A. To change this coding use the removal tool. Please refer to page 99.

**Recommend Torque value:**

		Extender	Body	Plastic Gland	Metal Gland	Hex-nut
Plug	RJ11F 6	/	5.0 Nm	3.0 Nm	/	/
Receptacle	RJ11F 7	/	/	/	/	10.2 to 10.7 Nm

# ASSEMBLY INSTRUCTION - RJFTV™

Metal range  
Composite range  
Cables and cordsets  
Adaptors and access points  
Accessories  
Assembly instructions  
How to order

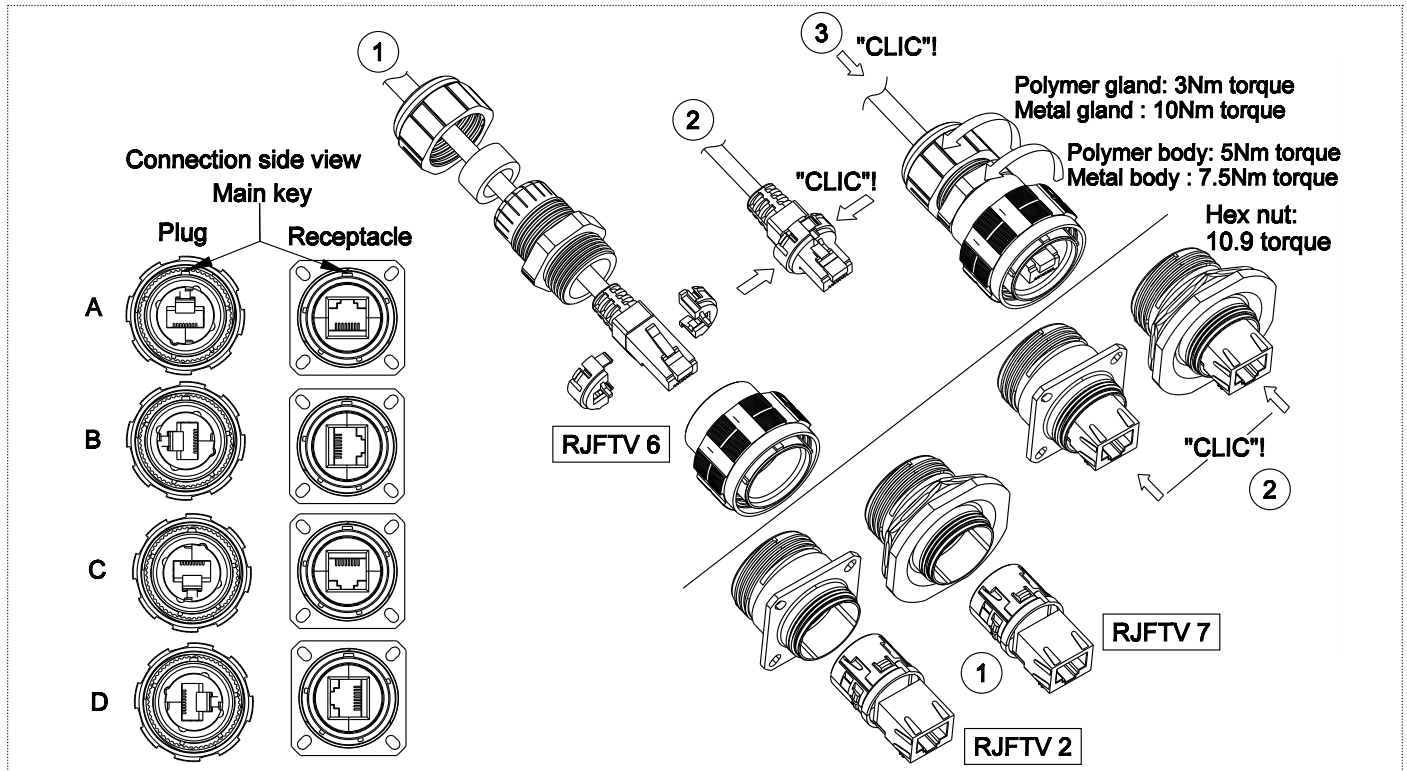

**Important note:**

- Can be assembled with all standard RJ45 cordset.
- No tool required for assembly.
- Choose your coding on plug side during the assembly. The standard coding on receptacle side is A. To change this coding use the removal tool. Please refer to page 99.

**Recommend Torque value:**

		Extender	Body	Plastic Gland	Metal Gland	Hex-nut
Plug	RJFTV 6	/	5.0 Nm	3.0 Nm	/	/
	RJFTV 6M	/	7.5 Nm	/	10.0 Nm	/
Receptacle	RJFTV 2 PE	3.0 Nm	5.0 Nm	3.0 Nm	/	/
	RJFTV 2 PEM	7.5 Nm	10.0 Nm	/	7.5 Nm	/
	RJFTV 7	/	/	/	/	10.9 Nm
	RJFTV 7 PE	3.0 Nm	5.0 Nm	3.0 Nm	/	10.9 Nm
	RJFTV 7 PEM	7.5 Nm	10.0 Nm	/	7.5 Nm	10.9 Nm

## Assembly video



See our assembly video on youtube : [www.youtube.com/AmphenolSocapex](http://www.youtube.com/AmphenolSocapex)

- Amphenol RJ Field Assembly - Rugged RJ45 connector



# ASSEMBLY INSTRUCTION - RJFRB

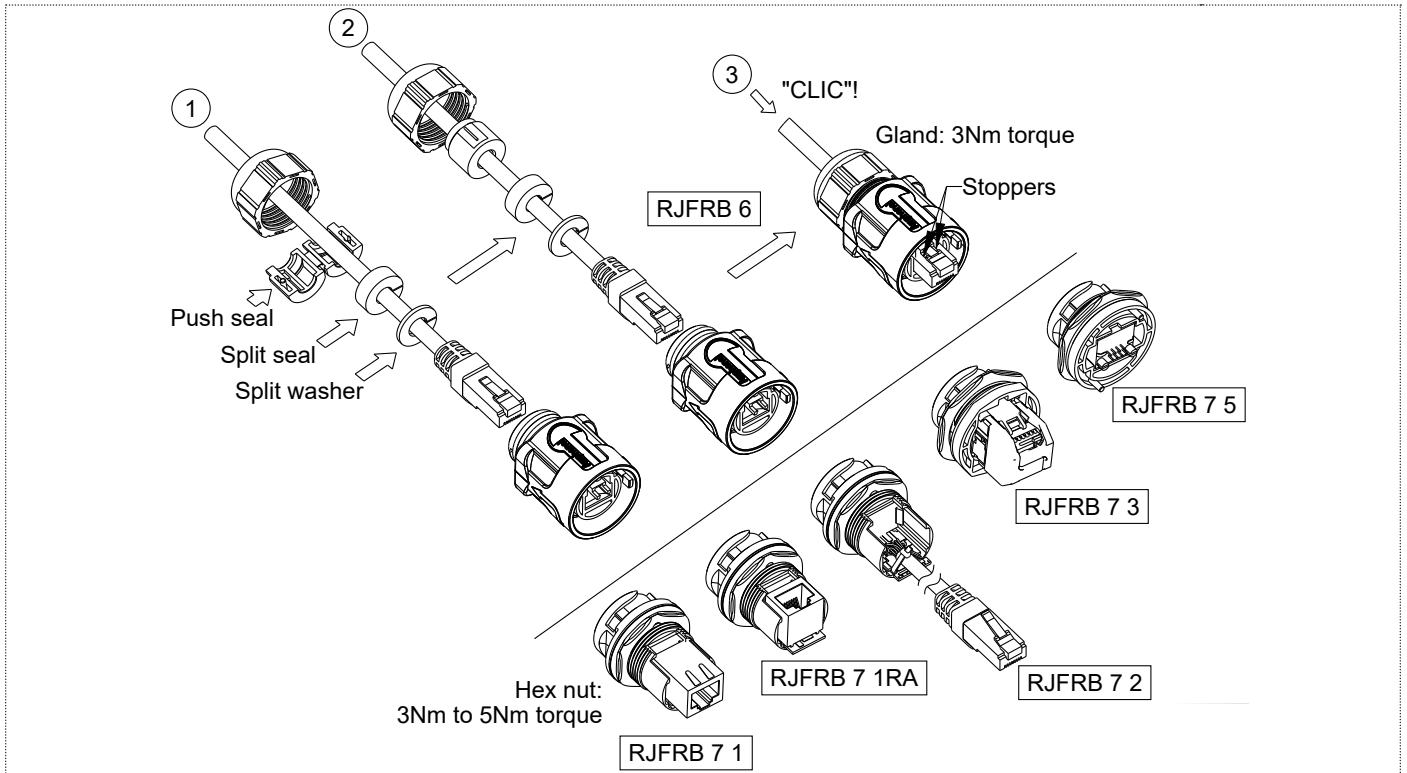

**Important note:**

- Can be assembled with all standard RJ45 cordset.
- No tool required.

**Recommend Torque value:**

		Plastic gland		Hex-nut	
Plug	RJFRB 6	3.0 Nm	/		
	RJFRB 7	/		3.0 to 5.0 Nm	
Receptacle					

Metal range

Composite range

Cables and cordsets

Adaptors and access points

Accessories

Assembly instructions

How to order

# ASSEMBLY INSTRUCTION - RJF544

Metal range  
 Composite range  
 Cables and cordsets  
 Adaptors and access points  
 Accessories  
 Assembly instructions  
 How to order

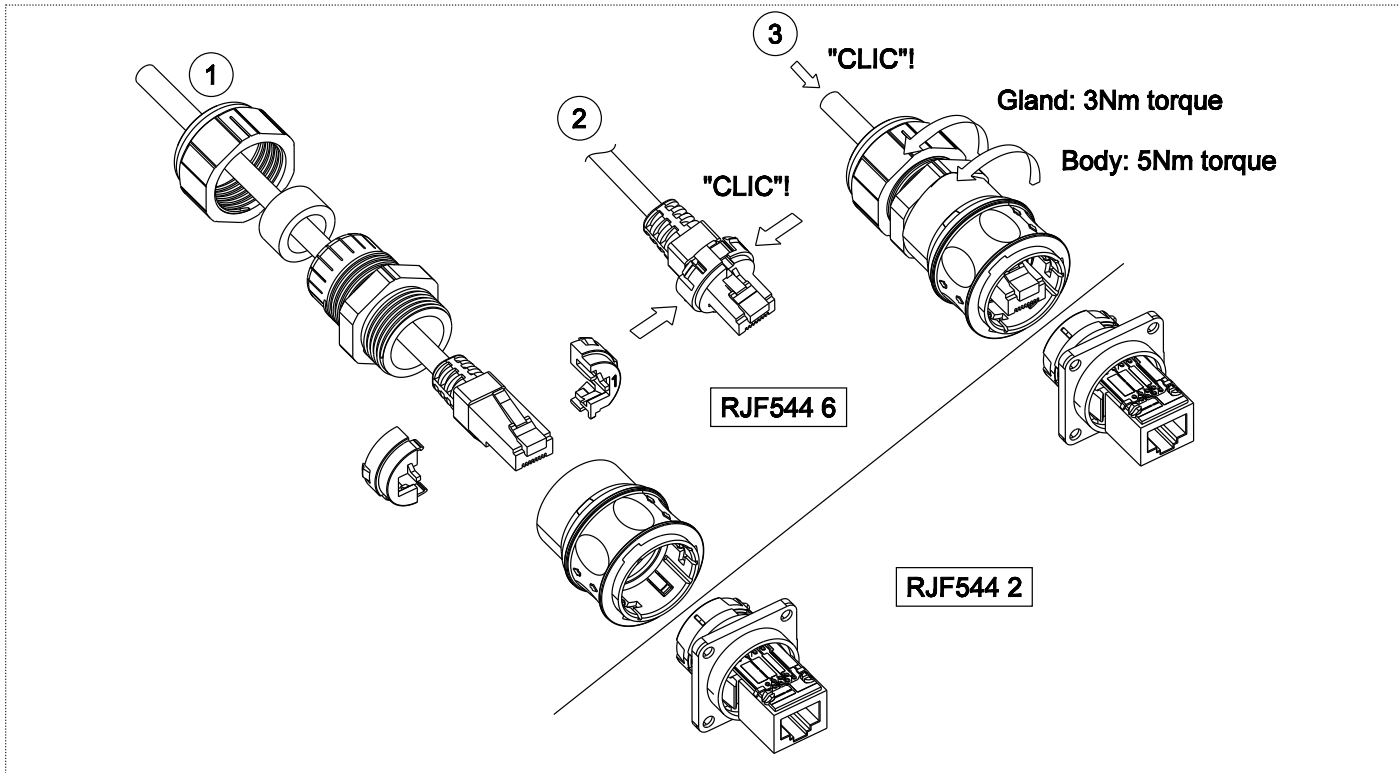

**Notes:**

- Can be assemble with all standard RJ45 cordset.
- No tool required.

**Recommend Torque value:**

Plug	RJF544 6	Plastic gland
		5.0 Nm

# NOTES

Area for handwritten notes, consisting of multiple horizontal dotted lines.

- Metal range
- Composite range
- Cables and cordsets
- Adaptors and access points
- Accessories
- Assembly instructions**
- How to order

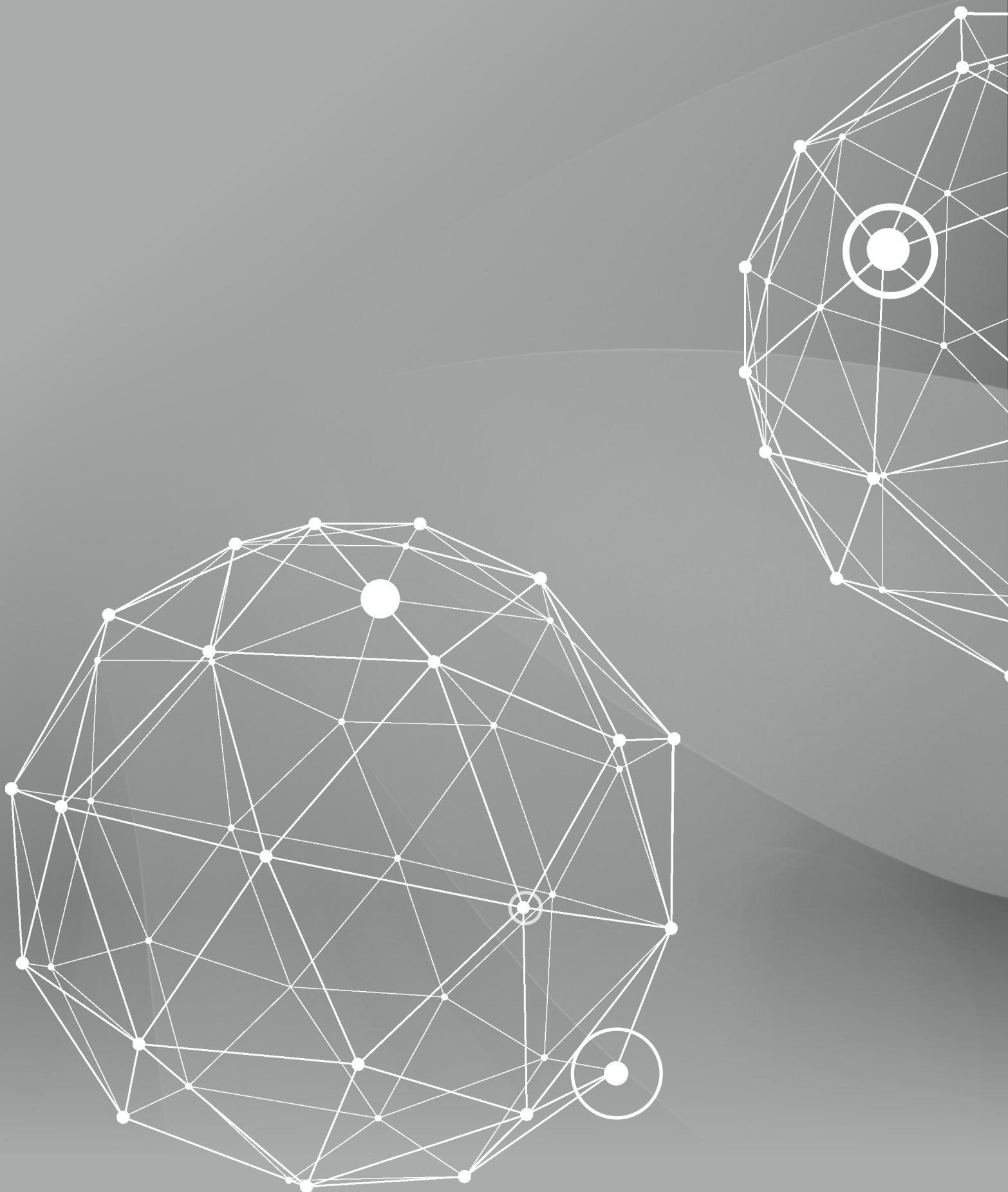

# HOW TO ORDER

## Table of contents

<b>HOW TO ORDER</b>	<b>109</b>
RJF™	110
RJF™ - Transversally sealed and hermetic	111
RJ11F	112
RJFTV™	113
RJFTV™ - Transversally sealed and hermetic	114
RJFTV™ - Stand-off receptacle	115
RJFTV™ - Reduced flange receptacle	116
RJFTV™ - Through-Bulkhead receptacle	117
RJFTV™ - Atex zone 2	118
RJ11FTV - Atex zone 2	119
RJFRB	120
RJF544	121
Cable	122
Cordset	123
Standard protective cap	124

# HOW TO ORDER - RJF™

Metal range  
Composite range  
Cables and cordsets  
Adaptors and access points  
Accessories  
Assembly instructions  
How to order

1.	2.	3.	4.	5.	6.	7.	8.
Series	Shell type	Coding (receptacle Cat.6 and Cat.6A only)	Backshell (receptacle only)	Back termination (receptacle only)	Shell material and finish	Cordset length (back termination type 2 only)	Cordset end (back termination type 2 only)
RJF	2		PE	1	N		

### 1. Series

RJF	Cat.5e Ethernet connector
RJF6	Cat.6 Ethernet connector (back termination 1 only)
RJF6A	Cat.6A Ethernet connector (back termination 1 and 1RA only)

### 2. Shell type

6	Plug	Plastic gland
6M		Metal gland
2	Square flange receptacle	
7	Jam nut receptacle	

### 3. Coding (receptacle Cat.6 and Cat.6A only)

A	Coding A
B	Coding B
C	Coding C
D	Coding D

### 4. Backshell and In line receptacle (receptacle only)

	Without backshell	
PE	Metal backshell	Plastic gland
PEM		Metal gland
PEWF	Metal In line receptacle	Plastic gland
PEMWF		Metal gland

### 5. Back termination (receptacle only)

1	Female RJ45
1RA	Right angle female RJ45
2	RJ45 cordset or PCB

### 6. Shell material and finish

B	Aluminium shell	Black Coating ✓
G		Olive Drab Cadmium plating
N		Nickel plating ✓
ZN		Black Zinc Nickel plating ✓

### 7. Cordset length (back termination type 2 only)

00	PCB with 8 tinned holes for cable soldering
3	0,3m [11.81 inches]
5	0,5m [19.68 inches]
10	1m [39.37 inches]
15	1,5m [59.05 inches]

### 8. Cordset end (back termination type 2 only)

100 BTX	RJ45 plug at the end
OPEN	Open RJ cable without plug at the end

### Examples :

Part number	Description
RJF7PE2N15100BTX	RJF Cat.5e, jam nut receptacle, with metal backshell and plastic gland, 1,5m cordset with RJ45 plug at the end, nickel plating
RJF62APEMWF1ZN	RJF Cat.6, square flange in line receptacle, coding A, metal backshell and metal gland, female RJ45 back termination, black zinc nickel plating
RJF6A7A1RAB	RJF Cat.6A, jam nut receptacle, coding A, right angle female RJ45 back termination, black coating

# HOW TO ORDER - RJF™ TRANSVERSALLY SEALED AND HERMETIC

1.	2.	3.	4.	5.	6.	7.	8.
Series	Shell type	Sealing type	Coding	Back termination	Shell material and finish	Cordset length (back termination type 2 only)	Cordset end (back termination type 2 only)
RJF	2	S	A	1RA	G		

## 1. Series

RJF	Cat.5e Ethernet connector
RJF6	Cat.6 Ethernet connector (back termination 1 only)
RJF6A	Cat.6A Ethernet connector (back termination 1 and 1RA only)

## 2. Shell type

2	Square flange receptacle
7	Jam nut receptacle

## 3. Sealing type

S	Transversally sealed receptacle
H	Hermetic receptacle

## 4. Coding

A	Coding A
B	Coding B
C	Coding C
D	Coding D

## 5. Back termination

1	Female RJ45
1RA	Right angle female RJ45
2	RJ45 cordset or PCB

## 6. Shell material and finish

B	Aluminium shell	Black Coating ✓
G		Olive Drab Cadmium plating
N		Nickel plating ✓
ZN		Black Zinc Nickel plating ✓

## 7. Cordset length (back termination type 2 only)

00	PCB with 8 tinned holes for cable soldering
3	0,3m [11.81 inches]
5	0,5m [19.68 inches]
10	1m [39.37 inches]
15	1,5m [59.05 inches]

## 8. Cordset end (back termination type 2 only)

100BTX	RJ45 plug at the end
OPEN	Open RJ cable without plug at the end

## Examples :

Part number	Description
RJF2SA2ZN05OPEN	RJF Cat.5e, transversally sealed square flange receptacle, coding A, 0,5m cordset with open end, black zinc nickel plating
RJF62HA1N	RJF Cat.6, hermetic square flange receptacle, coding A, female RJ45 back termination, nickel plating
RJF6A7SA1ZN	RJF Cat.6A, transversally sealed jam nut receptacle, coding A, female RJ45 back termination, black zinc nickel plating

## HOW TO ORDER - RJ11F

1.

2.

3.

4.

Series	Shell type	Back termination (receptacle only)	Shell finish
RJ11F	7	2	B

## 1. Series

RJ11F	RJ11 Field
-------	------------

## 2. Shell type

6	Plug
2	Square flange receptacle
7	Jam nut receptacle

## 3. Back terminations (receptacle only)

1	Female RJ11
2	PCB with 6 tinned holes for cable soldering

## 4. Shell finish

B	Aluminium shell	Black Coating ✓
G		Olive Drab Cadmium plating
N		Nickel plating ✓
ZN		Black Zinc Nickel plating ✓

## Examples :

Part number	Description
RJ11F21B	RJ11F, square flange receptacle, female RJ11 back termination, black coating
RJ11F72G	RJ11F, jam nut receptacle, PCB with 6 tinned holes for cable soldering back termination, olive drab cadmium plating
RJ11F6ZN	RJ11F, plug, black zinc nickel plating

✓ : RoHS compliant



# HOW TO ORDER - RJFTV™

1.	2.	3.	4.	5.	6.	7.	8.
Series	Shell type	Coding (receptacle Cat.6 and Cat.6A only)	Backshell (receptacle only)	Back termination (receptacle only)	Shell material and finish	Cordset length (back termination type 2 only)	Cordset end (back termination type 2 only)
RJFTV	2		PE	1	N		

### 1. Series

RJFTV	Cat.5e Ethernet connector
RJFTV6	Cat.6 Ethernet connector (back termination 1 only)
RJFTV6A	Cat.6A Ethernet connector (back termination 1 and 1RA only)

### 2. Shell type

6	Plug	Plastic gland
6M		Metal gland
2	Square flange receptacle	
7	Jam nut receptacle	

### 3. Coding (receptacle Cat.6 and Cat.6A only)

A	Coding A
B	Coding B
C	Coding C
D	Coding D

### 4. Backshell (receptacle only)

	Without backshell	
PE	Metal backshell	Plastic gland
PEM		Metal gland
PEMWF	Metal In line receptacle	

### 5. Back termination (receptacle only)

1	Female RJ45
1RA	Right angle female RJ45
2	RJ45 cordset or PCB

### 6. Shell material and finish

G	Aluminium shell	Olive Drab Cadmium plating
N		Nickel plating ✓
ZN		Black Zinc Nickel plating ✓
BZ	Marine bronze shell ✓	

### 7. Cordset length (back termination type 2 only)

00	PCB with 8 tinned holes for cable soldering
3	0,3m [11.81 inches]
5	0,5m [19.68 inches]
10	1m [39.37 inches]
15	1,5m [59.05 inches]

### 8. Cordset end (back termination type 2 only)

100BTX	RJ45 plug at the end
OPEN	Open RJ cable without plug at the end

### Examples :

Part number	Description
RJFTV6MN	RJFTV, plug with metal gland, nickel plating
RJFTV6A7CPEM1ZN	RJFTV Cat.6A, jam nut receptacle, coding C, metal backshell with metal gland, female RJ45 back termination, black zinc nickel plating
RJFTV6A7APEM1G	RJFTV Cat.6A, jam nut receptacle, coding A, metal backshell with metal gland, female RJ45 back termination, olive drab cadmium plating

# HOW TO ORDER - RJFTV™ TRANSVERSALLY SEALED AND HERMETIC

1.	2.	3.	4.	5.	6.	7.	8.
Series	Shell type	Sealing type	Coding	Back termination	Shell material and finish	Cordset length (back termination type 2 only)	Cordset end (back termination type 2 only)
RJFTV	2	5	A	1RA	G		

## 1. Series

RJFTV	Cat.5e Ethernet connector
RJFTV6	Cat.6 Ethernet connector (back termination 1 only)
RJFTV6A	Cat.6A Ethernet connector (back termination 1 and 1RA only)

## 2. Shell type

2	Square flange receptacle
7	Jam nut receptacle

## 3. Sealing type

S	Transversally sealed receptacle
H	Hermetic receptacle

## 4. Coding

A	Coding A
B	Coding B
C	Coding C
D	Coding D

## 5. Back termination

1	Female RJ45
1RA	Right angle female RJ45
2	RJ45 cordset or PCB

## 6. Shell material and finish

G		Olive Drab Cadmium plating
N	Aluminium shell	Nickel plating ✓
ZN		Black Zinc Nickel plating ✓
BZ	Marine bronze shell ✓	

## 7. Cordset length (back termination type 2 only)

00	PCB with 8 tinned holes for cable soldering
3	0,3m [11.81 inches]
5	0,5m [19.68 inches]
10	1m [39.37 inches]
15	1,5m [59.05 inches]

## 8. Cordset end (back termination type 2 only)

100BTX	RJ45 plug at the end
OPEN	Open RJ cable without plug at the end

## Examples :

Part number	Description
RJFTV7HA2G03100BTX	RJFTV Cat.5e, hermetic jam nut receptacle, coding A, 0,3m cordset with RJ45 plug at the end, olive drab cadmium plating
RJFTV67HA1N	RJFTV Cat.6, hermetic jam nut receptacle, coding A, female RJ45 back termination, nickel plating
RJFTV6A7SA1RAG	RJFTV Cat.6A, transversally sealed jam nut receptacle, coding A, right angle female RJ45 back termination, olive drab cadmium plating

# HOW TO ORDER - RJFTV™ STAND-OFF RECEPTACLE

1.	2.	3.	4.	5.	6.
Series	Shell type	Coding	Back termination	Shell material and finish	Deviation
RJFTV6A	2S	A	5	G	F459

## 1. Series

RJFTV6A	Cat.6A Ethernet connector
---------	---------------------------

## 2. Shell type

2S	Transversally sealed square flange receptacle
7S	Transversally sealed receptacle jam nut receptacle

## 3. Coding

A	Coding A
B	Coding B
C	Coding C
D	Coding D

## 4. Back termination

5	PC Tails
---	----------

## 5. Shell material and finish

G		Olive Drab Cadmium plating
N	Aluminium shell	Nickel plating ✓
ZN		Black Zinc Nickel plating ✓
BZ	Marine bronze shell ✓	

## 6. Deviation

F459	Stand-off
------	-----------

## Examples :

Part number	Description
RJFTV6A2SA5GF459	RJFTV Cat.6A, transversally sealed square flange receptacle, coding A, olive drab cadmium plating, PC tails back termination with stand-off deviation
RJFTV6A2SA5ZNF459	RJFTV Cat.6A, transversally sealed square flange receptacle, coding A, black zinc nickel plating, PC tails back termination with stand-off deviation
RJFTV6A7SA5BZF459	RJFTV Cat.6A, transversally sealed jam nut receptacle, coding A, marine bronze shell, PC tails back termination with stand-off deviation

# HOW TO ORDER - RJFTV™ REDUCED FLANGE RECEPTACLE

1. 2. 3. 4. 5. 6.

Series	Shell type	Coding (avoid the coding for Cat.5e in F312 version)	Back termination	Shell material and finish	Deviation
RJFTV	7S	A	5	G	F059

## 1. Series

RJFTV	Cat.5e Ethernet connector
RJFTV6	Cat.6 Ethernet connector
RJFTV6A	Cat.6A Ethernet connector

## 2. Shell type

7	Jam nut receptacle (mandatory for F312 and F311 deviation)
7S	Sealed jam nut receptacle (mandatory for F059 and F058 deviation)

## 3. Coding (avoid the coding for Cat.5e in F312 version)

A	Coding A
B	Coding B
C	Coding C
D	Coding D

## 4. Back termination

1	Female RJ45
5	PC tails (mandatory for F059 and F058)

## 5. Shell material and finish

G		Olive Drab Cadmium plating
N	Aluminium shell	Nickel plating ✓
ZN		Black Zinc Nickel plating ✓
BZ	Marine bronze shell ✓	

## 6. Deviation

F312	Jam nut reduced flange receptacle
F311	Jam nut reduced flange receptacle with safety castle nut
F059	Jam nut reduced flange, Stand-off receptacle
F058	Jam nut reduced flange, Stand-off receptacle with safety castle nut

## Examples :

Part number	Description
RJFTV67A1NF312	RJFTV Cat.6, jam nut receptacle, coding A, female RJ45 back termination, nickel plating, reduced flange deviation
RJFTV6A7A1ZNF312	RJFTV Cat.6A, jam nut receptacle, coding A, female RJ45 back termination, black zinc nickel plating, reduced flange deviation
RJFTV6A7SA5ZNF059	RJFTV Cat.6A, transversally sealed jam nut receptacle, coding A, black zinc nickel plating, PC tails back termination with reduced flange stand-off deviation

✓ : RoHS compliant

# HOW TO ORDER - RJFTV™ THROUGH-BULKHEAD RECEPTACLE

1.	2.	3.	4.
Series	Shell type	Shell material and finish	Metallization
RJFTVB	7	G	ISO BRUT

## 1. Series

RJFTVB	Cat.5e Ethernet Through Bulkhead
RJFTV6B	Cat.6 Ethernet Through Bulkhead

## 2. Shell type

2	Square flange receptacle
7	Jam nut receptacle

## 3 Back termination (receptacles only)

G		Olive Drab Cadmium plating
N	Aluminium shell	Nickel plating ✓
ZN		Black Zinc Nickel plating ✓
BZ	Marine bronze shell ✓	

## 4. Metallization

ISO BRUT	None Metallized insert
ISO NI	Metallized insert

## Examples :

Part number	Description
RJFTVB7GISOBRUT	RJFTV Cat.5e, through bulkhead jam nut receptacle, olive drab cadmium plating, none metallized insert
RJFTV6B7NISONI	RJFTV Cat.6, through bulkhead jam nut receptacle, nickel plating, metallized insert
RJFTVB2BZISONI	RJFTV Cat.5e, through bulkhead square flange receptacle, marine bronze shell, metallized insert

# HOW TO ORDER - RJFTV™ - ATEX ZONE 2

- Metal range
- Composite range
- Cables and cordsets
- Adaptors and access points
- Accessories
- Assembly instructions
- How to order

1.	2.	3.	4.	5.	6.
Series	Shell type	Coding (for receptacle only)	Back termination (for receptacle only)	Shells material and finish	Cordset option (back termination type 2 only)
RJFTVX	2S	A	2	G	03 100BTX

### 1. Series

RJFTVX	Cat.5e Ethernet connector - ATEX zone 2
RJFTVX6	Cat.6 Ethernet connector - ATEX zone 2 (back termination 1 only)

### 2. Shell type

6M	Plug	Metal gland
2S	Square flange receptacle	Transversally sealed
7S	Jam nut receptacle	Transversally sealed

### 3. Coding (for receptacle only)

A	Coding A
B	Coding B
C	Coding C
D	Coding D

### 4. Back termination

1	Female RJ45
2	RJ45 cordset

### 5. Shell material and finish

G	Aluminium shell	Olive Drab Cadmium plating
N		Nickel plating ✓

### 6. Cordset option (back termination type 2 only)

03 100BTX	0,3m [11.81 inches]
05 100BTX	0,5m [19.68 inches]
10 100BTX	1m [39.37 inches]
15 100BTX	1,5m [59.05 inches]

### Examples :

Part number	Description
RJFTVX62SB1N	RJFTV Cat.6, atex zone 2, transversally sealed square flange receptacle, coding B, female RJ45 back termination, nickel plating
RJFTVX7SA2N03100BTX	RJFTV Cat.5e, atex zone 2, transversally sealed jam nut receptacle, coding A, 0,3m cordset with RJ45 plug at the end, nickel plating
RJFTVX6MN	RJFTV, atex zone 2, plug with metal gland, nickel plating

# HOW TO ORDER - RJ11FTV - ATEX ZONE 2

1.	2.	3.	4.	5.
Series	Shell type	Coding (for receptacle only)	Back termination (for receptacle only)	Shells material and finish
RJ11FTV X	2S	A	2	G

## 1. Series

RJ11FTVX	RJ11FTV Field - ATEX zone 2
----------	-----------------------------

## 2. Shell type

6M	Plug	Metal gland
2S	Square flange receptacle	Transversally sealed
7S	Jam nut receptacle	Transversally sealed

## 3. Coding (for receptacle only)

A	Coding A
B	Coding B
C	Coding C
D	Coding D

## 4. Back termination

1	Female RJ45
---	-------------

## 5. Shell material and finish

G	Aluminium shell	Olive Drab Cadmium plating
N		Nickel plating ✓

## Examples :

Part number	Description
RJ11FTVX6MG	RJF11TV, atex zone 2, plug with metal gland, olive drab cadmium plating
RJ11FTVX7SA1G	RJF11TV, atex zone 2, transversally sealed jam nut receptacle, female RJ11 back termination, olive drab cadmium plating
RJ11FTVX2SA1N	RJF11TV, atex zone 2, transversally sealed square flange receptacle, female RJ11 back termination, nickel plating

✓ : RoHS compliant

# HOW TO ORDER - RJFRB

1.

2.

3.

4.

Series	Shell type	Back termination (receptacle only)	Cordset length (back termination type 2 only)
RJFRB	7	1RA	

### 1. Series

**RJFRB** Cat.5e and Cat.6 Ethernet connector

### 2. Shell type

**6** Plug  
**7** Jam nut receptacle

### 3 Back termination (receptacles only)

**1** Female RJ45  
**1RA** Right angle female RJ45  
**2** RJ45 cordset  
**3U** IDC Cat.6 - Unshielded  
**3F** IDC Cat.6 - Partial shielding  
**3S** IDC Cat.6 - Totaly shielded  
**5** PC tails

### 4. Cordset length (back termination type 2 only)

**03 100BTX** 0,3m [11.81 inches]  
**05 100BTX** 0,5m [19.68 inches]  
**10 100BTX** 1m [39.37 inches]  
**15 100BTX** 1,5m [59.05 inches]

### Examples :

Part number	Description
RJFRB6	RJFRB Cat.5e, plug
RJFRB75	RJFTV Cat.5e, jam nut receptacle, PC tails
RJFRB7203100BTX	RJFTV Cat.5e, jam nut receptacle, 0,3m cordset with RJ45 plug at the end

- Metal range
- Composite range
- Cables and cordsets
- Adaptors and access points
- Accessories
- Assembly instructions
- How to order



## HOW TO ORDER - RJF544

1.	2.	3.	4.	5.
Series	Shell type	Receptacle option (shell type 2 only)	Back termination (shell type 2 only)	Cordset length (back termination type 2 only)
RJF544	2	SM	1RA	

**1. Series**

RJF544	Cat.5e Ethernet connector
RJF5446	Cat.6 Ethernet connector (back termination type 1 only)

**2. Shell type**

6	Composite push-pull plug
2	Composite square flange receptacle

**3. Receptacle option (shell type 2 only)**

	Without option
S	Transversally sealing
M	Metallized composite shell
SM	Transversally sealed and metallized composite shell

**4. Back termination (shell type 2 only)**

1	Female RJ45
1RA	Right angle female RJ45
2	RJ45 cordset

**5. Cordset length (back termination type 2 only)**

03 100BTX	0,3m [11.81 inches]
05 100BTX	0,5m [19.68 inches]
10 100BTX	1m [39.37 inches]
15 100BTX	1,5m [59.05 inches]
00	PCB with 8 tinned holes for cable soldering

**Examples :**

Part number	Description
RJF54421	RJF544 Cat.5e, square flange receptacle, female RJ45 back termination
RJF5442210100BTX	RJF544 Cat.5e, square flange receptacle, 1,0m cordset with RJ45 plug at the end
RJF54462M1	RJF544 Cat.6, square flange receptacle with metallized composite shell, female RJ45 back termination

## HOW TO ORDER - CABLE

Part number	Ethernet categorie	Lenght	
<a href="#">191-038045-00</a>	Cat.5E	100 m	328 ft
<a href="#">191-038045-01</a>	Cat.5E	300 m	984 ft
<a href="#">191-031179-00</a>	Cat.6	100 m	328 ft
<a href="#">191-031179-01</a>	Cat.6	300 m	984 ft
<a href="#">191-031190-00</a>	Cat.6A	100 m	328 ft
<a href="#">191-031190-01</a>	Cat.6A	300 m	984 ft
<a href="#">191-031200-00</a>	Cat.7	100 m	328 ft
<a href="#">191-031200-01</a>	Cat.7	300 m	984 ft
<a href="#">191-031700-00</a>	Cat.7 - VG95218	1 000 m	3 280 ft

✓ : RoHS compliant

# HOW TO ORDER - CORDSET

1.	2.	3.	4.
Series	Cordsets	Ethernet categorie	Lenght
RJF	SFTP	5E	0350

## 1. Series

RJF	RJF Cordset
-----	-------------

## 2. Cordsets

SFTP	Shielded and Foiled Twisted Pair
------	----------------------------------

## 3. Ethernet categorie

5E	Cat.5E
----	--------

6	Cat.6
---	-------

6A	Cat.6A
----	--------

7	Cat.7
---	-------

## 4. Lenght

0075	0,75 m	2,46 ft
------	--------	---------

0100	1,00 m	3,28 ft
------	--------	---------

0150	1,50 m	4,92 ft
------	--------	---------

0200	2,00 m	6,56 ft
------	--------	---------

0250	2,50 m	8,20 ft
------	--------	---------

0300	3,00 m	9,84 ft
------	--------	---------

0350	3,50 m	11,48 ft
------	--------	----------

0400	4,00 m	13,12 ft
------	--------	----------

0450	4,50 m	14,76 ft
------	--------	----------

0500	5,00 m	16,40 ft
------	--------	----------

0600	6,00 m	19,68 ft
------	--------	----------

0700	7,00 m	22,96ft
------	--------	---------

0800	8,00 m	26,24 ft
------	--------	----------

0900	9,00 m	29,52 ft
------	--------	----------

1000	10,00 m	32,80 ft
------	---------	----------

1500	15,00 m	49,20 ft
------	---------	----------

2000	20,00 m	65,60 ft
------	---------	----------

2500	25,00 m	82,00 ft
------	---------	----------

3000	30,00 m	98,40 ft
------	---------	----------

3500	35,00 m	114,80 ft
------	---------	-----------

4000	40,00 m	131,20 ft
------	---------	-----------

4500	45,00 m	147,60 ft
------	---------	-----------

5000	50,00 m	164,00 ft
------	---------	-----------

6000	60,00 m	196,80 ft
------	---------	-----------

### Important note:

- Cordsets are with RJ45 plug overmolded on each end.

### Examples :

Part number	Description
RJFSFTP60450	Cat5e cordset, 4,50m lenght
RJFSFTP6A4500	Cat6 cordset, 45,00m lenght
RJFSFTP70300	Cat7 cordset, 3,00m lenght

# HOW TO ORDER - STANDARD PROTECTIVE CAP

- Metal range
- Composite range
- Cables and cordsets
- Adaptors and access points
- Accessories
- Assembly instructions
- How to order

1.	2.	3.	4.	5.
Series	Connector type	Wire type	Shell material and finish	Deviation
RJF C	6		B	

### 1. Series

RJF C	RJF standard protective cap
RJFTV C	RJFTV standard protective cap
RJ11F C	RJ11F standard protective cap
RJ11FTV C	RJ11FTV standard protective cap

### 2. Connector type

6	Plug
2	Square flange receptacle
7	Jam nut receptacle

### 3. Wire type

	Nylon cord
M	Metallic chain
MR	Stainless steel rope with teflon jacket

### 4. Shell material and finish

B	Aluminium shell	Black Coating ✓
G		Olive Drab Cadmium plating
N		Nickel plating ✓
ZN		Black Zinc Nickel plating ✓
BZ	Marine bronze shell ✓	

### 5. Deviation

F057	Reduced flange protective cap ( RJFTV C only)
------	---

### Examples :

Part number	Description
RJFC2N	RJF protective cap for square flange receptacle, nylon cord, nickel plating
RJFTVC2MRN	RJFTV protective cap for square flange receptacle, stainless steel rope with teflon jacket, nickel plating
RJ11FTVC6ZN	RJ11FTV protective cap for plug, nylon cord, black zinc nickel plating

# NOTES

Area with horizontal dotted lines for taking notes.

Metal range

Composite range

Cables and cordsets

Adaptors and access points

Accessories

Assembly instructions

How to order



## ABOUT AMPHENOL

Founded in 1932, **Amphenol** is one of the largest manufacturers of interconnect products in the world. The company designs, manufactures, and markets electrical, electronic, and fiber optic connectors, interconnect systems, and coaxial and specialty cables.

**Amphenol** has a diversified presence as a leader in high growth areas of the interconnect industry and provides solutions for customers in the automotive, broadband, industrial, information technology and data communications, military and aerospace, mobile devices, and mobile networks markets.

More info on [www.amphenol.com](http://www.amphenol.com)

**Amphenol**  
ENABLING THE ELECTRONICS REVOLUTION

**Amphenol Military & Aerospace Operations (AMAO)** has the largest and broadest selection of interconnect products in the military and aerospace markets.

More info on [www.amphenolmao.com](http://www.amphenolmao.com)

**Amphenol**  
MILITARY & AEROSPACE

### Europe

FRANCE	Amphenol AIR LB	2 rue Clément Ader, ZAC de Wé - 08110 Carignan	+33 3 24 22 78 49
FRANCE	Amphenol SEFEE	Z.I. des Cazes – BP243 - 12402 Saint-Affrique Cedex	+33 5 65 98 11 00
GERMANY	Amphenol AIR LB GMBH	Am Kleinbahnhof 4 - 66740 Saarlouis	+49 6831 981 00
ITALY	Amphenol EUROPEAN SALES OPERATIONS	Via Barbaiana n.5 - 20020 Lainate - Milano	+39 293 254 214
UNITED KINGDOM	Amphenol INVOTEC	Unit 1-3, Hedging Lane Industrial Estate, Dosthill - Tamworth, B77 5HH	+44 1827 263 000
UNITED KINGDOM	Amphenol IONIX SYSTEMS	Prospect House, Taylor Business Park, Risley, Warrington, WA3 6HP	+44 1 942 685 200
UNITED KINGDOM	Amphenol LTD	Thanet Way, Whitstable - KENT, CT53JF	+44 1227 773 200
UNITED KINGDOM	Amphenol MARTEC	St Augustines Business Park, Swalecliffe Whitstable - Kent CT5 2QJ	+44 1227 793 733

### North America

CANADA	Amphenol CANADA	605 Milner avenue - Toronto, Ontario	+1 416 291 0647
USA	Amphenol AEROSPACE OPERATIONS	40-60 Delaware street - Sidney, NY 13838	+1 800 678 0141
USA	Amphenol BORISH TECHNOLOGIES	4511 East Paris AVE - Grand Rapids, MI 49512	+1 616 554 9820
USA	Amphenol FSI	1300 Central Expwy N, Suite 100 - Allen, TX 75013	+1 214 547 2400
USA	Amphenol GRIFFITH ENTERPRISES	6000 East Coury Drive - Cottonwood, AZ 86326	+1 928 634 3685
USA	Amphenol NEXUS TECHNOLOGIES	50 Sunnyside Avenue - Stamford, CT 06902	+1 203 327 7300
USA	Amphenol PCD	72 Cherry Hill Drive - Beverly, MA. 01915	+1 978 624 3400
USA	Amphenol PRINTED CIRCUIT	Board Technology, 91 Northeastern Boulevard - Nashua, NH 03062	+1 603 324 4500
USA	Amphenol SV MICROWAVE	2400 Centrepark West Drive - West Palm Beach, FL	+1 561 840 1800
USA	Amphenol TIMES MICROWAVE	358 Hall Avenue - Wallingford, CT 06492	+1 800 867 2629

### Asia

CHINA	Amphenol PCD CO.	Building 21, 1 <sup>st</sup> Liao Keng Industrial Zone, Shi Yan Street - Bao An District - Shenzhen 518108	+86 755 8173 8000/8286
INDIA	Amphenol INTERCONNECT INDIA	105 Bhosari Industrial Area - Pune 411 026	+91 20 27120363
JAPAN	Amphenol JAPAN	471-1, Deba, Ritto-City - Shiga 520 3041	+81 77 553 8501
KOREA	Amphenol DAESHIN	558 SongNae-Dong SoSa-Gu, Bucheon-city, Kyunggi-Do - 420-130	+81 32 610 3830/3845
SINGAPORE	Amphenol EAST ASIA	26/F, Railway Plaza, 39 Chatham Road South, Tsim Sha Tsui, Kowloon, Hong Kong	+65 6294 2128

### Other Areas

AFRICA	Amphenol AFRICA	30 Impala Rd - Sandton 2146	+27 82 410 5179
ARGENTINA	Amphenol ARGENTINA	Av. Callao 930 2do piso Oficina B "Plaza" C1023 - AAP Buenos Aires	+54 11 4815 6886
AUSTRALIA	Amphenol AUSTRALIA PTY	2 Fiveways Blvd., Keysborough - Melbourne - Victoria 3173	+61 3 8796 8888
BRAZIL	Amphenol DO BRAZIL	Rua Diogo Moreira, 132, 20 andar, rooms 2001-2-3	+55 11 3815 1003
ISRAEL	Amphenol BAR-TEC	3 Hagavish Street, K fir-Barkan Bldg. East Industrial Zone - Kfar-Sava, 44102	+972 9 764 4100
MEXICO	Amphenol OPTIMIZE	Carretera Internacional Km 6.5, Col. Parque Industrial, Nogales, Sonora, C.P. 84094	+52 631 311 160
NEW ZEALAND	Amphenol PHITEK	Level 4, 2 Kingdon Street, Newmarket, Auckland 1023	+64 9 524 2984
RUSSIA	Amphenol RUSSIA	Yaroslavskaja Street 8 - 129164 Moscow	+7 495 937 6341
TURKEY	Amphenol TURKEY	Sun Plaza 15 Kat: 15 Maslak Hah. Bilim Sok. No.5 - Sisli/Istanbul, 34398	+90 212 367 92 19

# Amphenol SOCAPEX



## Amphenol Socapex

948, promenade de l'Arve BP29  
74311 Thyez Cedex - France  
Phone: +33 (0)4 50 89 28 00  
[contact@amphenol-socapex.fr](mailto:contact@amphenol-socapex.fr)  
[www.amphenol-socapex.com](http://www.amphenol-socapex.com)



## For Technical Support

+33 (0)4 50 89 28 49  
[technicalsupport@amphenol-socapex.fr](mailto:technicalsupport@amphenol-socapex.fr)  
[www.amphenol-socapex.com/technical\\_support](http://www.amphenol-socapex.com/technical_support)



## To buy our products

+33 (0)4 50 90 28 00  
[contact@amphenol-socapex.fr](mailto:contact@amphenol-socapex.fr)  
[www.amphenol-socapex.com/amphenol/sales](http://www.amphenol-socapex.com/amphenol/sales)  
Request a quote online at [www.amphenol-socapex.com/quotation\\_request](http://www.amphenol-socapex.com/quotation_request)



## Documentation

[www.amphenol-socapex.com/documentation](http://www.amphenol-socapex.com/documentation)  
To order a paper version of our catalogs, send an e-mail to [communication@amphenol-socapex.fr](mailto:communication@amphenol-socapex.fr)



[www.amphenol-socapex.com](http://www.amphenol-socapex.com)

Follow Amphenol Socapex on social media :    

*This catalog uses paper from managed forests, PEFC & FSC labels, and is printed by a printer certified "Imprim'Vert®"*

*We reserve the right to modify our products in any way we deem necessary.  
Any duplication is prohibited, unless approved in writing.*

Designed by **Amphenol Socapex**  
DOC-001041-ANG - August 2022